

Koro **Fresh brew Plus**

UK English



DOC. NO.	H 253U 00
EDITION 1	04 - 2005

N&W GLOBAL VENDING S.p.A.

Sede legale: Via Roma 24
24030 Valbrembo (BG) Italia

Telefono +39 035 606111
Fax +39 035 606460
www.nwglobalvending.com

Cap. Soc. € 40.000.000 i. v.
Reg. Imp. Bergamo, Cod. Fisc. e Part. IVA: 03138870161
R.E.A. Bergamo n. 352618
Cod. ISO: IT 03138870161

DICHIARAZIONE DI CONFORMITA'
DECLARATION OF CONFORMITY
DÉCLARATION DE CONFORMITÉ
KONFORMITÄTSEKTLÄRUNG
DECLARACIÓN DE CONFORMIDAD
DECLARAÇÃO DE CONFORMIDADE
VERKLARING VAN OVEREENSTEMMING
INTYG OM ÖVERENSSTÄMMELSE
OVERENSSTEMMELSESERKLÆRING
YHDENMUKAISUUSTODISTUS

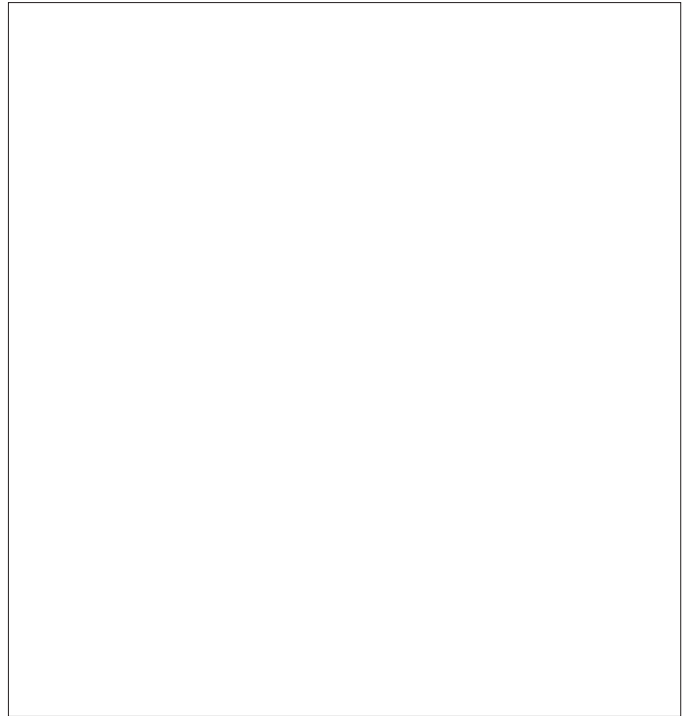

Valbrembo, 01/04/2005

Dichiara che la macchina descritta nella targhetta di identificazione, è conforme alle disposizioni legislative delle direttive: **98/37/CE, 89/336, 73/23 CEE** e successive modifiche ed integrazioni.

Declares that the machine described in the identification plate conforms to the legislative directions of the directives: **98/37/CE, 89/336, 73/23 EEC** and further amendments and integrations.

Déclare que l'appareil décrit dans la plaque signalétique satisfait aux prescriptions des directives: **98/37/CE, 89/336, 73/23 CEE** et modifications/intégrations suivantes.

Erklärt, daß das im Typenschild beschriebene Gerät den **EWG** Richtlinien **98/37/CE, 89/336, 73/23** sowie den folgenden Änderungen/Ergänzungen entspricht.

Declara que la máquina descrita en la placa de identificación, resulta conforme a las disposiciones legislativas de las directivas: **98/37/CE, 89/336, 73/23 CEE** y modificaciones y integraciones sucesivas.

Declara que o distribuidor descrita na chapa de identificação é conforme às disposições legislativas das directivas **98/37/CE, 89/336 e 73/23 CEE** e sucessivas modificações e integrações.

Verklaart dat de op de identificatieplaat beschreven machine overeenstemt met de bepalingen van de **EEG** richtlijnen **98/37/CE, 89/336 en 73/23** en de daaropvolgende wijzigingen en aanvullingen.

Intyggar att maskinen som beskrivs på identifieringsskylten överensstämmer med lagstiftningsföreskrifterna i direktiven: **98/37/CE, 89/336, 73/23 CEE** och påföljande och kompletteringar.

Det erklæres herved, at automaten angivet på typeskiltet er i overensstemmelse med direktiverne **98/37/CE, 89/336 og 73/23 EU** og de senere ændringer og tillæg.

Forsikrer under eget ansvar at apparatet som beskrives i identifikasjonsplaten, er i overensstemmelse med vilkårene i EU-direktivene **98/37/CE, 89/336, 73/23** med endringer.

Vahvistaa, että arvokyltissä kuvattu laite vastaa **EU**-direktiivien **98/37/CE, 89/336, 73/23** sekä niihin myöhemmin tehtyjen muutosten määräyksiä.

ANTONIO CAVO

C.E.O



THE INTERNATIONAL CERTIFICATION NETWORK

CERTIFICATE

**IQNet and its partner
CISQ/IMQ-CSQ**

hereby certify that the organization

NECTA VENDING SOLUTIONS SPA

VIA ROMA 24 - 24030 VALBREMBO (BG) Italy

VIA DEL CHIOSO ANG. CAPITANI DI MOZZO - 24030 MOZZO (BG) Italy

for the following field of activities

Design, manufacturing and sale of electronic/electromechanical vending machines

*Refer to quality manual for details of applications to ISO 9001:2000 requirements
has implemented and maintains a*

Quality Management System

which fulfills the requirements of the following standard

ISO 9001:2000

Issued on: 2002 - 09 - 04

Registration Number: IT - 12979



Fabio Roversi
President of IQNet



Gianrenzo Prati
President of CISQ

IQNet partners*:

AENOR, Spain AFAQ, France AIB-Vinçotte International Belgium APCER, Portugal CISQ, Italy CQC, China CQM, China CQS, Czech Republic DQS, Germany DS, Denmark ELOT, Greece FCAB, Brazil FONDONORMA, Venezuela HKQAA, Hong Kong ICONTEC, Colombia IRAM, Argentina IQA, Japan KEMA, Netherlands KFQ, Korea MSZT, Hungary NCS, Norway NSAI, Ireland OQS, Austria PCBC, Poland PSB, Singapore QMI, Canada SFS, Finland SII, Israel SIO, Slovenia SOS, Switzerland IQNet is represented in the USA by the following partners: AFAQ, AIB-Vinçotte International, CISQ, DQS, KEMA and NSAI

*The list of IQNet partners is valid at the time of issue of this certificate. Updated information is available under www.iqnet-certification.com

Federazione - Federation



a member of IQNet

CISQ è una Federazione consorziale ed indipendente di enti di certificazione dei Sistemi di Gestione aziendali, operanti ciascuno nel settore di propria competenza.

CISQ is a multi-sector, independent, non-profit Federation of Italian organizations for the certification of company Management Systems, each operating in its own sector of responsibility.

CERTIFICAZIONE DEI SISTEMI DI GESTIONE AMBIENTALE DELLE AZIENDE
CERTIFICATION OF COMPANIES ENVIRONMENTAL MANAGEMENT SYSTEMS



CERTIFICATO n. **9191.ZAV2**
CERTIFICATE n.

SI CERTIFICA CHE IL SISTEMA DI GESTIONE AMBIENTALE DI
WE HEREBY CERTIFY THAT THE ENVIRONMENTAL MANAGEMENT SYSTEM OPERATED BY

NECTA VENDING SOLUTIONS S.p.A.

SITO
SITE

Via Roma, 24 - 24030 VALBREMBO (BG)

UNI EN ISO 14001

È CONFORME ALLA NORMA
IS IN COMPLIANCE WITH THE STANDARD

PER LE SEGUENTI ATTIVITÀ
CONCERNING THE FOLLOWING ACTIVITIES

Apparecchiature elettromeccaniche/elettroniche per la
distribuzione automatica e la ristorazione
Electronic/electromechanical vending-machines

IL PRESENTE CERTIFICATO È SOGGETTO AL RISPETTO DEL REGOLAMENTO
PER LA CERTIFICAZIONE DEI SISTEMI QUALITÀ EDI GESTIONE DELLE AZIENDE
THE USE AND THE VALIDITY OF THE CERTIFICATE SHALL SATISFY THE REQUIREMENTS
OF THE RULES FOR THE CERTIFICATION OF COMPANY QUALITY AND MANAGEMENT SYSTEMS

Prima emissione
First issue

19 Dicembre 1997

Emissione corrente
Current issue

31 Marzo 2000

La validità del presente certificato è subordinata a sorveglianza annuale e al riesame completo del Sistema di Gestione Ambientale con periodicità triennale secondo le procedure dell'IMQ S.p.A.
The validity of the certificate is submitted to annual audit and a reassessment of the entire Environmental Management System within three years according to IMQ S.p.A. rules

IMQ - VIA QUINTILIANO, 43 - 20138 MILANO



E.A. 19

English

TABLE OF CONTENTS

INTRODUCTION	PAGE 2	NOTES ON PROGRAMMING	PAGE 15
IDENTIFICATION OF THE VENDING MACHINE	PAGE 2	SWITCHING ON	PAGE 15
IN THE EVENT OF FAILURES	PAGE 2	OPERATING MODES	PAGE 15
TRANSPORT AND STORAGE	PAGE 2	NORMAL OPERATING MODE	PAGE 15
POSITIONING THE VENDING MACHINE	PAGE 3	SURFING MODE	PAGE 16
WARNING FOR INSTALLATION	PAGE 3	FILLER MENU	PAGE 16
PRECAUTIONS IN USING THE MACHINE	PAGE 3	STATISTICS	PAGE 16
WARNING FOR SCRAPPING	PAGE 3	SELECTION PRICES	PAGE 17
TECHNICAL SPECIFICATIONS	PAGE 3	CHANGE TUBES CONTROL	PAGE 17
POWER CONSUMPTION	PAGE 4	DISPLAYING THE TEMPERATURE	PAGE 17
ACCESSORIES	PAGE 4	TEST DISPENSING	PAGE 17
LOADING AND CLEANING	PAGE 5	GSM PRE-ALARMS	PAGE 17
MAINS SWITCHES	PAGE 5	EVADTS TRANSFER	PAGE 17
HYGIENE AND CLEANING	PAGE 5	FILLER MENU MASKING	PAGE 17
USING THE VENDING MACHINE	PAGE 5	TECHNICIAN MENU	PAGE 18
CONTROLS AND INFORMATION	PAGE 6	FAILURES	PAGE 18
LOADING INSTANT PRODUCTS	PAGE 6	VENDING MACHINE PARAMETERS	PAGE 21
WASHING THE MIXERS	PAGE 6	STATISTICS	PAGE 23
FILLING THE WATER SUPPLY TANK	PAGE 7	TEST	PAGE 23
CLEANING THE WASTE TRAYS	PAGE 7	MISCELLANEOUS	PAGE 24
DISASSEMBLING AND CLEANING THE MIXERS	PAGE 7	MAINTENANCE	PAGE 25
SUSPENDING FROM USE	PAGE 8	INTRODUCTION	PAGE 25
CLEANING THE FRESH-BREW UNIT	PAGE 8	SANITISING THE MIXERS	PAGE 25
INSTALLATION	PAGE 10	REGENERATION OF THE SOFTENER UNIT	PAGE 26
MAINS SWITCHES	PAGE 10	MAINTENANCE OF THE BREWER UNIT	PAGE 27
UNPACKING THE VENDING MACHINE	PAGE 10	MAINTENANCE OF THE BOILER	PAGE 27
CONNECTION TO THE WATER MAINS	PAGE 10	PERIODICAL CLEANING	PAGE 28
CONNECTION TO THE POWER SUPPLY	PAGE 11	PRINTED BOARD FUNCTIONS AND INDICATOR LAMPS	PAGE 29
INSTALLING THE PAYMENT SYSTEM	PAGE 12	ACTUATION BOARD	PAGE 29
WATER SOFTENER UNIT	PAGE 12	PUSH-BUTTON BOARD	PAGE 30
INSERTING THE LABELS	PAGE 12	BOILER CONTROL BOARD	PAGE 30
INITIALISING	PAGE 13	SIGMA BREWER CONTROL BOARD	PAGE 31
FILLING THE WATER SYSTEM	PAGE 13	FRESH BREW HYDRAULIC SYSTEM	PAGE 32
BREWER UNIT CYCLE	PAGE 14	PROGRAMMING MENU SUMMARY	PAGE 34
CHECKING AND ADJUSTING THE MACHINE SETTINGS	PAGE 14	WIRING DIAGRAM	PAGE 43

INTRODUCTION

This technical documentation is part and parcel of the vending machine and must always follow the machine in case it is moved or transfer of ownership, so as to allow consultation by different operators.

Before starting installation and using the machine, it is first necessary to carefully read and understand the instructions contained in this manual, as they offer important information on installation safety, operating instructions and maintenance.

This manual is divided into three chapters.

The **first chapter** describes the loading and routine maintenance operations which are carried out in areas of the machine accessible with simple use of the door key, without using any other tools.

The **second chapter** contains the instructions for correct installation and all information necessary for optimum use of the machine.

The **third chapter** describes maintenance operations which involve the use of tools to access potentially dangerous areas.

The operations described in the second and third chapters must be carried out only by personnel who have the specific knowledge of the machine functioning from a point of view of electrical safety and health regulations.

IDENTIFICATION OF THE VENDING MACHINE AND ITS CHARACTERISTICS

Each machine is identified by its own serial number, indicated on the rating plate attached inside the cabinet on the right side.

This plate (see Figure below) is the only one acknowledged by the manufacturer and indicates all of the data which readily and safely gives technical information supplied by the manufacturer. It also assists in spare parts management.

IN THE EVENT OF FAILURES

In most cases, any technical problems are corrected by small repair operations; however, before contacting the manufacturer we recommend that this manual be read carefully.

Should there be serious failures or malfunctions, contact the following:

NECTA
VENDING SOLUTIONS SpA
Via Roma 24
24030 Valbrembo
Italy - Tel. +39 - 035606111

TRANSPORT AND STORAGE

To prevent any damage, special care should be taken when loading or unloading the vending machine.

The machine can be lifted by a motor-driven or manual fork lift truck, and the blades are to be placed underneath the machine.

Do not:

- overturn the vending machine;
- drag the vending machine with ropes or similar;
- lift the vending machine by its sides;
- lift the vending machine with slings or ropes;
- shake or jolt the vending machine and its packing.

The machine should be stored in a dry room where the temperature remains between 0°C and 40°C.

Using the original packing, no more than 2 machines can be stacked one on top of the other and must always kept upright as indicated by the arrows on the packing.

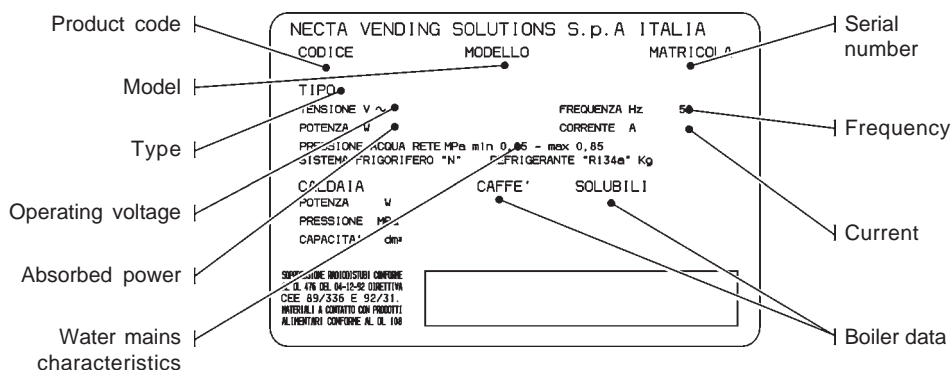

Fig. 1

POSITIONING THE VENDING MACHINE

The vending machine is not suitable for outdoor installation. It must be positioned in a dry room where the temperature remains between 2°C and 32°C, and not where water jets are used for cleaning (e.g. in large kitchens, etc.).

The machine should be placed close to a wall, so that the back panel is at a minimum distance of 4 cm from it and correct ventilation may be ensured. The machine must never be covered with cloth or the like.

The machine should be positioned with a maximum inclination of 2°.

Important notice!!

Access to the machine interior for maintenance and/or repairs is via the back panel and from the side panels. Therefore the machine is designed to be rotated, thus allowing removal of the back panel and of the side panels.

Installation on the cabinet

The machine can be installed on a table or on any other suitable stand (recommended height is 830).

If possible, it is advisable to use the special cabinet, which can house the liquid waste tray, the water supply kit, the payment system and, in the case of very hard water, the softener unit.

Alternatively, the water supply kit and the payment systems can be housed in special side modules that can be positioned on the base of the cabinet.

WARNING FOR INSTALLATION

The machine installation and the following maintenance operations should be carried out by qualified personnel only, who are trained in the correct use of the machine according to the standards in force.

The machine is sold without payment system, therefore the installer of such system has sole responsibility for any damage to the machine or to things and persons caused by faulty installation.

The integrity of the machine and compliance with the standards of the relevant systems must be checked at least once a year by qualified personnel.

All packing materials shall be disposed of in a manner which is safe for the environment.

PRECAUTIONS IN USING THE MACHINE

The following precautions will assist in protecting the environment:

- use biodegradable products only to clean the machine;
- adequately dispose of all containers of the products used for loading and cleaning the machine;
- switch the machine off during periods of inactivity, thus achieving considerable energy savings.

WARNING FOR SCRAPPING

Whenever the machine is to be scrapped, the laws in force regarding environment protection should be strictly observed. More specifically:

- ferrous and plastic materials and the like are to be disposed of in authorized areas only;
- insulating materials should be recovered by qualified companies;

TECHNICAL SPECIFICATIONS

DIMENSIONS

Height	500	mm
Width (with external tank)	508	mm
Depth	528	mm
Overall depth with door open	724	mm
Height of cabinet	830	mm
Weight	28	Kg

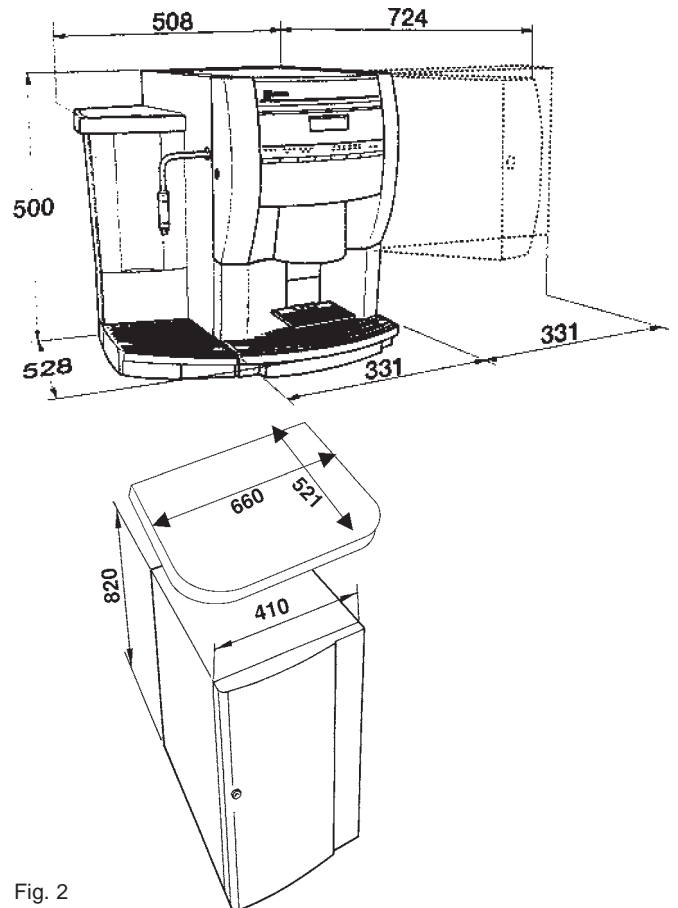

Fig. 2

Power supply voltage	230	V~
Power supply frequency	50	Hz
Installed power		W

PAYMENT SYSTEM

The machine is supplied with all prearrangement for the installation, using special kits, of payment systems with Executive, MDB or BDV protocol.

The payment systems must be housed in the special side module (optional).

SALES PRICES

A different programmable price can be set for each selection;

the standard setting has the same sales price for all selections.

WATER SUPPLY

From the mains, with a pressure of 0.05 to 0.85 MPa (0.5 to 8.5 bar).

The machine can be equipped with water supply tanks of different capacity, housed in an external module or in the base cabinet.

AVAILABLE ADJUSTMENTS

Espresso coffee dose by grinder rotation number.

Time adjustment for water and product doses.

Water temperature adjusted via software.

CONTROLS

- Presence of water
- top panel switch
- Operating temperature reached

SAFETY DEVICES

- Main switch
- Door switch
- Presence of solid waste tray
- Presence of liquid waste container
- Manual-reset boiler safety thermostat
- Air-break float jamming (only with water supply from the mains)
- Overflow solenoid valve (only with water supply from the mains)
- Double temperature relief valve for anti-boiling function (instant boiler only)
- Timer protection for:
 - Pump
 - Coffee unit ratiomotor
- Overheating protection for:
 - Doser units
 - Coffee unit ratiomotor
 - Magnets
 - Pump
 - Mixers
- Fuse protection for:
 - Main electrical circuit
 - Board power supply transformer

CAPACITY OF CONTAINERS

Capacity of containers (grams)	Instant	Fresh brew
Fresh coffee		350
Coffee beans		
Milk	290	
Chocolate	650	
Tea		400

POWER CONSUMPTION

The machine power consumption depends on many factors, such as the temperature and ventilation of the room where it is installed, the inlet water and boiler temperature, etc.

With an ambient temperature of 22° C the following power consumption levels resulted:

To reach operating temperature W/h

For 24 h in stand-by W/h

The above power consumption calculated from average data should only be taken as an indication.

ACCESSORIES

A wide range of accessories can be installed on the machine to vary its performance:

The installation kits are supplied with their own installation and test instructions, which must be strictly observed to ensure the machine safety.

Important notice!!

The use of kits which are not approved by the manufacturer of the vending machine does not guarantee compliance with safety standards, especially for energised parts.

The manufacturer declines all responsibility for the use of non approved components.

Installation and the following testing operations must be carried out exclusively by personnel who have a specific knowledge of the machine functions from a point of view of electrical safety and health regulations.

Chapter 1 LOADING AND CLEANING

MAINS SWITCHES

General

A general switch is fitted outside the machine, disconnecting the power from the machine without having to open the door. The terminal strip supporting the line cable, the fuses and the noise suppressor stay energised in any case.

Door

When opening the door a special switch disconnects the power from the machine electrical system to allow the operations described below, regarding loading and routine cleaning, in full safety.

All operations requiring the machine to be energized should be carried out by qualified personnel ONLY, informed about the specific risks of such situation.

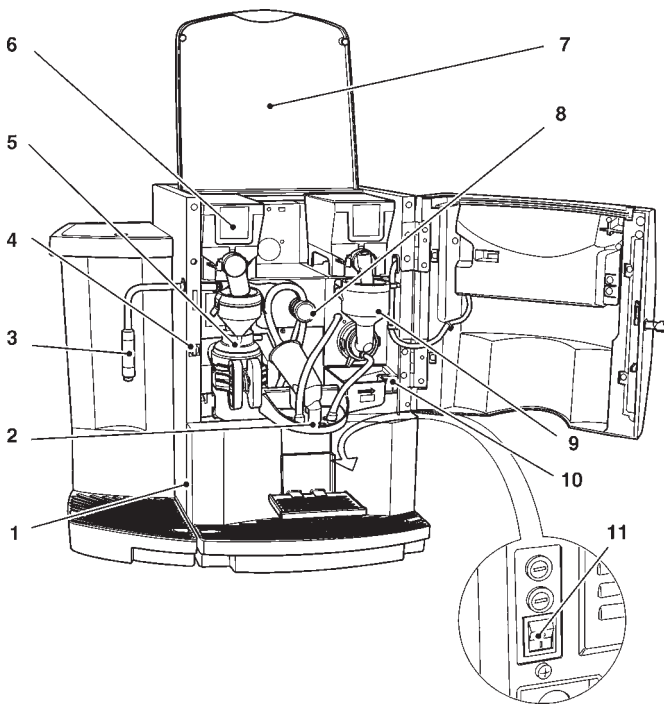

Fig. 3

- 1 - Liquid waste tray detection micro-switch
- 2 - Spout support
- 3 - Jug filling nozzle (FB only)
- 4 - Door switch
- 5 - Brewer unit
- 6 - Containers
- 7 - Machine top panel
- 8 - Mug-jug diverter
- 9 - Instant prod. mixer
- 10 - Spouts support release button
- 11 - Main external switch

HYGIENE AND CLEANING

According to current safety and health rules and regulations, the operator of an automatic vending machine is responsible for the hygiene of materials that come in contact with foodstuff; therefore he must carry out maintenance on the machine to prevent the formation of bacteria.

At installation the hydraulic circuits and the parts in contact with foodstuff should be fully sanitised to remove any bacteria which might have formed during storage.

The machine is not suitable for outdoor installation, it must be installed in a dry room where the temperature remains between 2°C and 32°C.

It is advisable that specific sanitising products are used for cleaning also the surfaces which are not directly in contact with foodstuff.

Some parts of the machine can be damaged by strong detergents.

The manufacturer declines all responsibility for damage caused by non-compliance with the above instructions or by the use of strong or toxic chemical agents.

Before starting any maintenance operations requiring parts of the unit to be removed, the machine must always be switched off.

Do not use sprayed water for cleaning the machine.

USING THE VENDING MACHINES OF HOT DRINKS IN OPEN CONTAINERS (e.g. Plastic cups, ceramic cups, jugs)

Vending machines for drinks in open containers should be used only to sell and dispense drinks obtained by:

- brewing fresh products like coffee or tea;
- reconstituting instant and lyophilised products.

These products should be declared by the manufacturer as "suitable for automatic vending" in open containers.

The dispensed products should be consumed immediately. They should never be preserved and/or packed for later consumption.

Any other use is unsuitable and thus potentially dangerous.

CONTROLS AND INFORMATION

The machine should operate at an ambient temperature of 2°C to 32°C.

The user controls and information are located on the outside of the door (see Fig. 4).

The labels with the selection menu and the operating instructions supplied with the machine must be inserted at the time of installation, referring to the selection dose table.

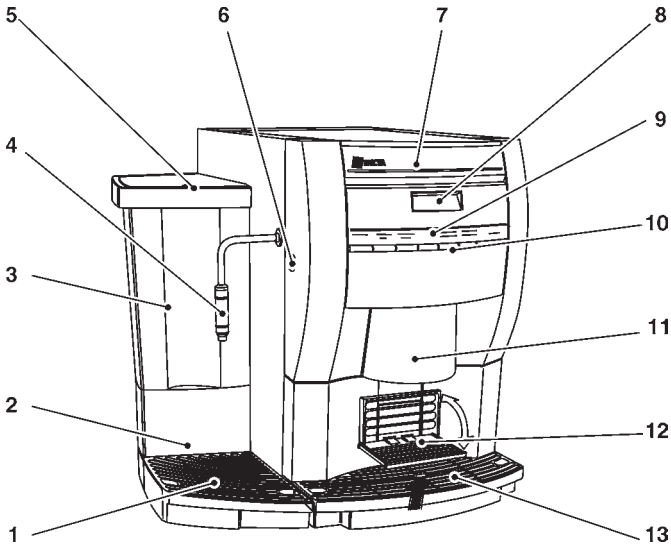

Fig. 4

- 1 - Jug support tray
- 2 - Water supply pump compartment
- 3 - External water tank (optional)
- 4 - Jug filling nozzle (Fresh-brew only)
- 5 - Tank lock
- 6 - Machine lock
- 7 - Logo label
- 8 - Alphanumeric display
- 9 - Selection menu label
- 10 - Selection buttons
- 11 - Dispensing spouts
- 12 - Cup support
- 13 - Liquid waste tray

The Programming button, to access the machine functions, and mixer cleaning button are located inside the machine on the right-hand side of the push-button card.

NOISE LEVEL

The continuous, weighted equivalent acoustic pressure level is below 70 dB.

LOADING INSTANT PRODUCTS

Open the machine top panel and slide the container lids, fill the single containers with the appropriate products, taking care not to compress them to prevent packing. Make sure the products do not contain any clots.

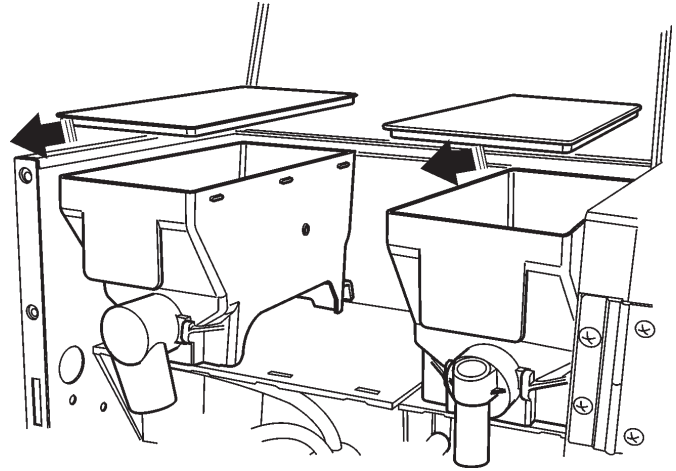

Fig. 5

WASHING THE MIXERS

The mixer must be cleaned daily and every time the machine is refilled to prevent clogging of the mixer if any product is accidentally spilled during refilling.

It must be cleaned also after the mixer sanitising operations, as described in the relevant chapter.

The mixer is cleaned with the door closed, doing as follows:

- press button 8 for 2 seconds

The display will indicate the request for a password;

- press in a quick succession buttons 4 4 8 8 to start cleaning.

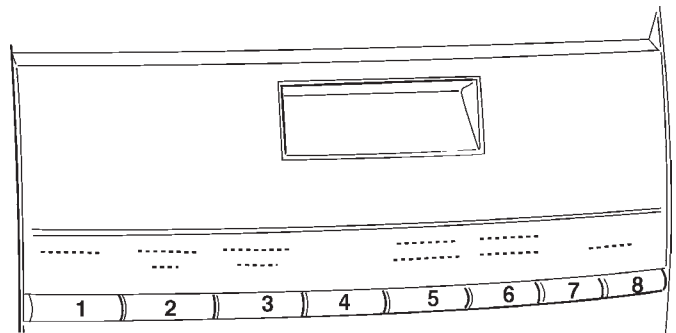

Fig. 6

FILLING THE WATER SUPPLY TANK

For the machine using a water tank located in the cabinet or inside or outside the machine, the tank must be cleaned at least once a week.

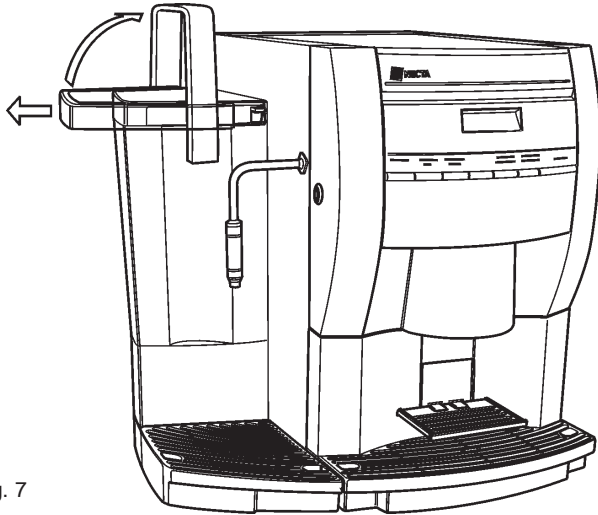
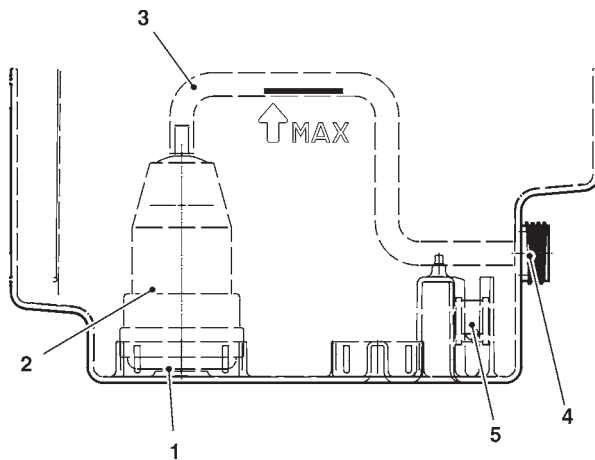

Fig. 7

- 1 - Cartridge coupling
- 2 - Filter cartridge
- 3 - Priming hose
- 4 - Quick coupling
- 5 - Magnetic float

Fig. 8



The water tank can house a softener filter that when used for the first time must be filled as follows:

- insert the filter in its seat;
- fill the tank up to and not exceeding the maximum level, allowing time for the filtering cartridge to fill;
- connect the silicone tube of the tank to the filter.

If the priming tube is connected to the empty tank, the cartridge empties and it will be necessary to fill the tank before reconnecting the tube.

CLEANING THE WASTE TRAYS

The waste trays can be easily removed even with the door closed (see Fig. 9) permitting quick emptying and cleaning. The fresh product container capacity is greater than that of the waste tray (if the base cabinet is not used).

The machine control software indicates on the display that the maximum number of coffee selections has been reached with the message "Waste tray full".

The waste tray must be emptied **without switching the machine off** (with the door closed), to allow the software to detect the operation. After a few seconds without tray the display shows the message "Insert waste tray" and the counters are reset.

With the solid waste tray removed, the machine is still available for instant drink selections but indicating the message "Insert waste tray" on the display.

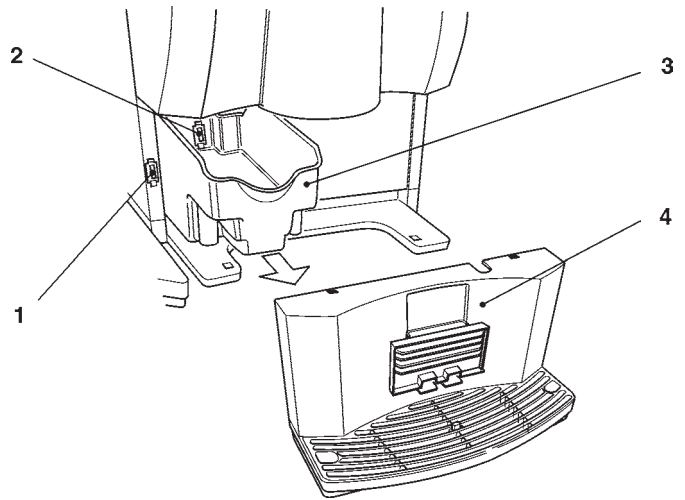

Fig. 9

- 1 - Compartment tray detection micro-switch
- 2 - Grounds tray detection micro-switch
- 3 - Solid waste tray
- 4 - Dispensing compartment drip tray

DISASSEMBLING AND CLEANING THE MIXERS

When installing the machine, and then at least once a week or even more frequently according to the use of the machine and the quality of the inlet water, the mixers and the dispensing conduits must be thoroughly sanitised (cleaned and disinfected), to guarantee proper hygiene of the dispensed products.

The parts to be cleaned are as follows:

- powder deposit drawers, mixer and instant drink dispensing conduit;
- dispensing spouts;
- spout support tray;
- remove the powder and the water funnels, the feeders, the powder deposit drawers and the mixer wheels from the mixers (see Fig. 10);

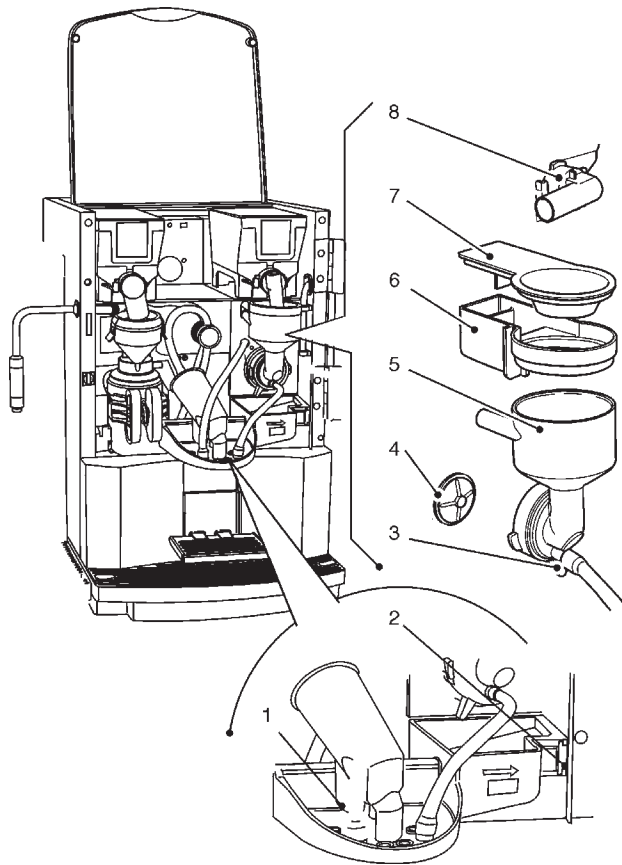

Fig. 10

- 1 - Dispensing spouts
- 2 - Spouts support release button
- 3 - Funnel securing ring nut
- 4 - Mixer impeller
- 5 - Water funnel
- 6 - Powder deposit box
- 7 - Powder funnel
- 8 - Powder dispensing pipette

- in order to remove the water funnel, rotate the green ring nut anti-clockwise;

pay special attention to closing it fully during reassembly;

- in order to remove the impellers, block the disk fitted on the mixer shaft with a finger (see Fig. 11).

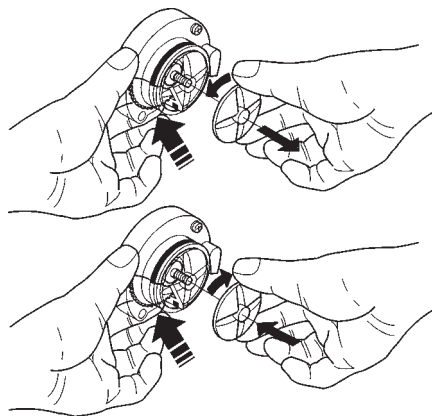

Fig. 11

SUSPENDING FROM USE

If for any reason the machine is switched off for a period exceeding the use-by date of the products, the following will be necessary:

- completely empty the containers and thoroughly wash them with the sanitising products used to clean the mixers;
- completely empty the coffee doser unit by dispensing coffee until the empty condition is indicated.
- completely empty the water tank.

CLEANING THE FRESH-BREW UNIT

Periodically, according to the operating condition of the machine and in any case at least weekly, it will be necessary to clean all parts that come into contact with the drink.

Washing can be carried out in a dishwasher (60°C max) or using normal dishware detergent.

The parts to be cleaned are indicated in the figure.

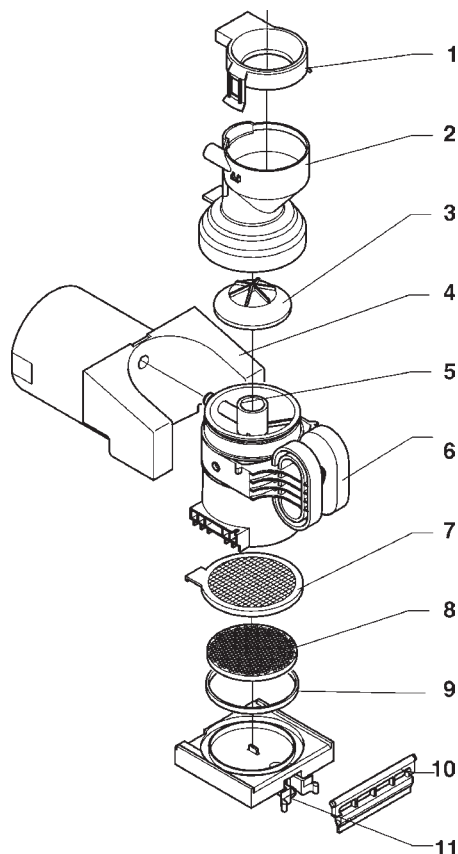
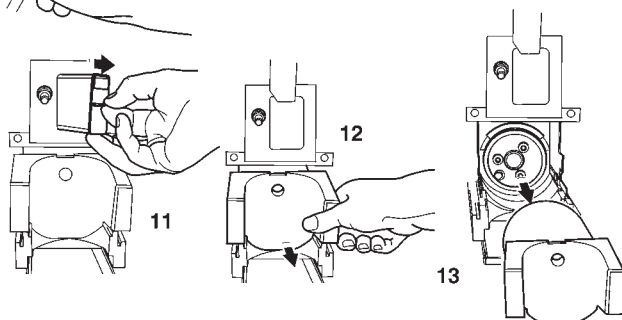
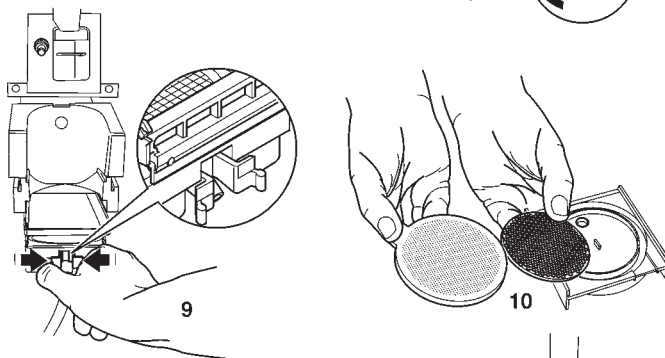
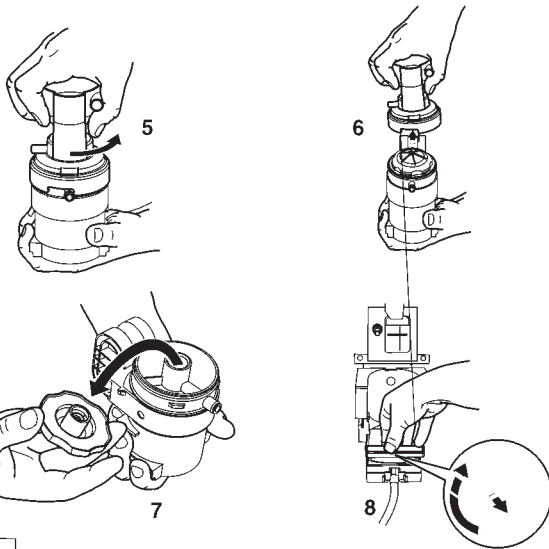
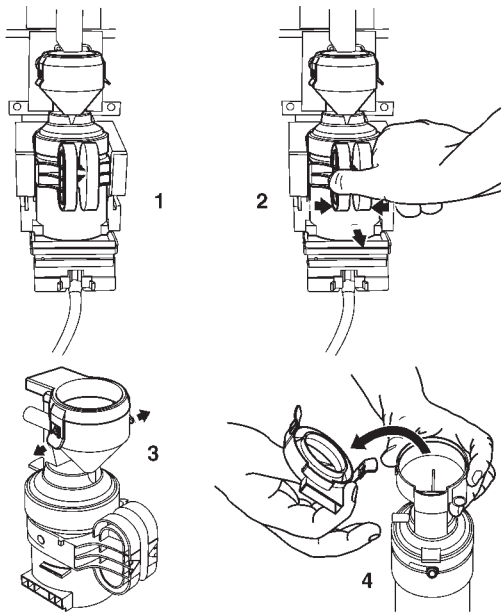

Fig. 12

- 1 - Upper cover
- 2 - Mixer feeder
- 3 - Upper valve
- 4 - Pressure cylinder
- 5 - Brewing chamber
- 6 - Chamber grip
- 7 - Filter
- 8 - Filter gasket
- 9 - Filter support
- 10 - Scraper
- 11 - Filter support spring

The disassembly sequence is indicated below:

Fig. 13



After removing all parts, wash them thoroughly with food-safe detergents (dishware detergents) and dry them. The filter should be replaced periodically in any case. Reassemble all parts as indicated below:

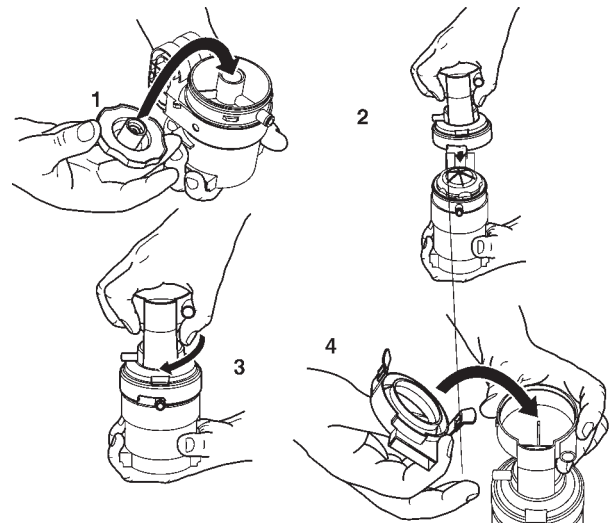
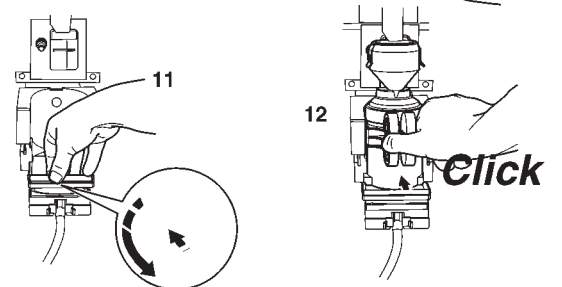
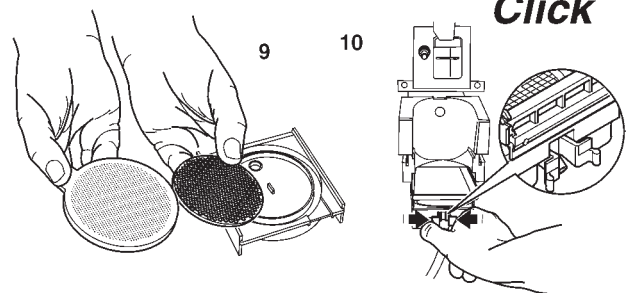
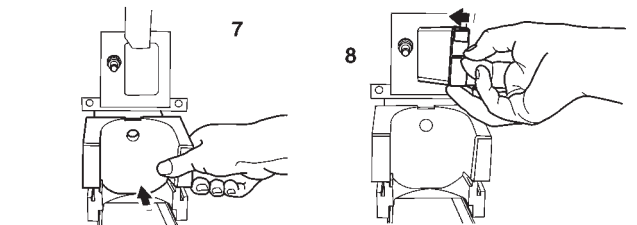
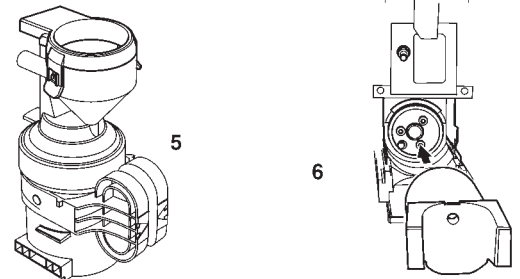

Fig. 14



Chapter 2 INSTALLATION

Installation and the following maintenance operations should be carried out with the **machine switched on** and therefore by qualified personnel only, who are trained in the correct use of the machine and informed about the specific risks of such situation.

The machine is not suitable for outdoor installation, it must be installed in a dry room where the temperature remains between 2°C and 32°C.

The machine cannot be installed where water jets are used for cleaning.

At installation the hydraulic circuits and the parts in contact with foodstuff should be fully sanitised to remove any bacteria which might have formed during storage.

MAINS SWITCHES

General

A general switch is fitted outside the machine, disconnecting the power from the machine without having to open the door. The terminal strip supporting the line cable, the fuses and the noise suppressor stay energised in any case.

Door

When opening the door a special micro-switch disconnects the power from the machine electrical system.

To energize the system with the open door, simply insert the special yellow key into the slot (see Fig. 15).

The switch on key must not be left inside the machine, it must be kept by the qualified personnel trained in the use of the machine.

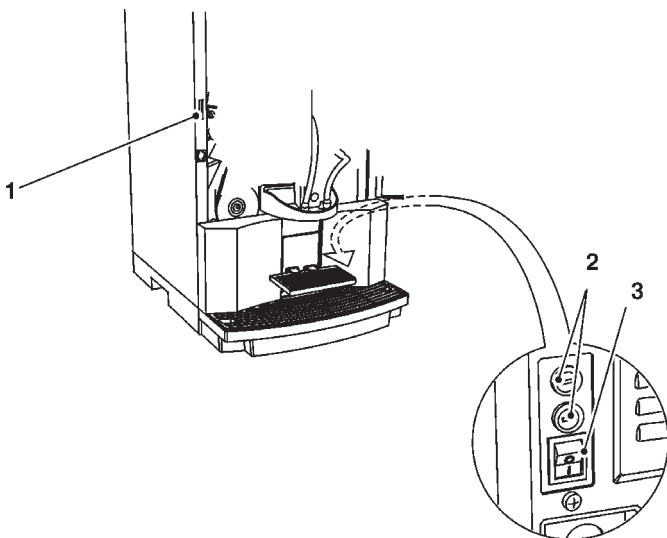

Fig. 15

- 1 - Door switch
- 2 - Mains fuses
- 3 - Main external switch

With the door open, there is no access to energised parts. Inside the machine, the only parts that stay energised are those protected by covers and carrying a plate with the warning "Disconnect the power before removing the protective cover".

Before removing such covers disconnect the power supply cable from the grid.

The door can be closed only after removing the key from the door switch.

UNPACKING THE VENDING MACHINE

After removing the packing, ensure that the machine is intact.

If in doubt do not use the machine.

No packing elements (i.e. plastic bags, polystyrene foam, nails, etc.) should be left within the reach of children, as they are potentially dangerous.

Packing materials must be disposed of in authorised containers and the recyclable ones must be recovered by qualified companies.

Important notice!!

The machine should be positioned with a maximum inclination of 2°.

CONNECTING THE MACHINE TO THE WATER MAINS

Some models can be connected to the drinking water mains, taking into account law provisions in force in the country where the machine is installed.

The mains water pressure must be 0.05 to 0.85 MPa (0.5-8.5 bar).

Run some water from the mains until it is clear and without impurities.

Use a hose (also available as a kit) capable of withstanding the water mains pressure and suitable for use with foodstuff (min. inside diameter of 6 mm) to connect the water supply to the union (3/4" gas) of the water inlet solenoid valve (see Fig. 16).

It is good practice to install the water supply tap outside the machine in an easily accessible position.

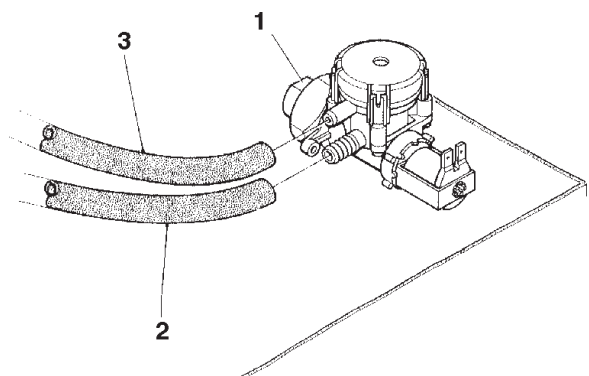

Fig. 16

- 1 - Water inlet union (3/4" gas)
- 2 - Water supply hose
- 3 - Overflow hose

OVERFLOW DEVICE

The water inlet solenoid valve (see Fig. 16) is equipped with an overflow device which mechanically stops the water inlet if there is a malfunction in the solenoid valve or in the boiler water level control device.

To restore normal operation, proceed as follows:

- drain the water contained in the overflow hose;
- shut off the water supply using the tap outside the machine;
- loosen the nut which secures the solenoid valve supply hose to relieve the water mains residual pressure and then tighten again (see Fig. 16);
- open the tap and switch the machine on.

CONNECTING THE MACHINE TO THE POWER SUPPLY

The machine is designed to operate under a single-phase 230 V~ voltage and is protected by 15 A fuses.

Before making the connection, ensure that the rating corresponds to that of the power grid, and more specifically:

- the supply voltage rating must be within the range recommended for the connection points;
- the main switch should be capable of withstanding the peak load required, and at the same time ensure proper omni polar disconnection from the power grid with an opening gap of the contacts of at least 3 mm.

The switch, the power outlet and the plug must be located in an easily accessible position, so that the cable can be disconnected in the event of intervention..

The power supply cable is of the type with a fixed plug. Any replacement of the power cable (see Fig. 16) should be made by qualified and suitably trained personnel only using cables type HO5 RN - F or HO5 V V-F or H07 RN-F with a 3x1-1.5 mm² section.

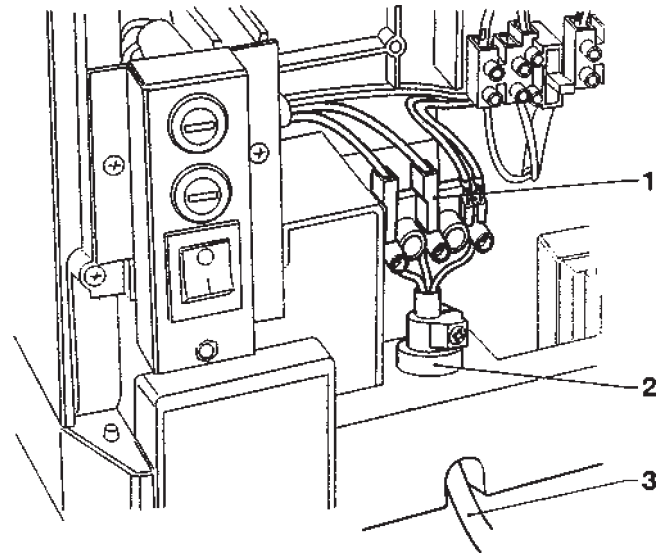

Fig. 16

- 1 - Connection terminal strip
- 2 - Cable clamp
- 3 - Power supply cable

The electrical safety of the machine is ensured only when it is correctly earthed according to the safety standards in force.

This fundamental safety requirement must be duly verified, and if in doubt the system must be carefully tested by qualified technicians.

Do not use adapters, multiple sockets and/or extensions.

Before switching the machine on, be sure it is correctly connected to the water mains and the cut-off valve is open.

THE MANUFACTURER DECLINES ALL RESPONSIBILITY FOR ANY DAMAGE CAUSED BY NON-COMPLIANCE WITH THE ABOVE MENTIONED SAFETY RULES.

INSTALLING THE PAYMENT SYSTEM

The machine is sold without payment system, therefore the installer of such a system is responsible for any damage to the machine or to things and persons caused by faulty installation.

Payments systems such as validators, "change-giver" and "cashless" can be installed by using the specific kits.

Payment systems such as "change giver" must be physically housed in the special side module (optional).

WATER SOFTENER UNIT

The machine is sold without water softener.

Should the mains water be very hard, a 2-litre ion-exchange resin water softener unit can be installed in the cabinet.

The water softener, available as accessory, must be replaced or regenerated regularly following the directions from the manufacturer.

For health and functional reasons, higher capacity water softener units should not be used.

In the event of water supply from the tank, the special filtering cartridges can be used.

The cartridges must be replaced periodically according to the water quality and to the instructions from the manufacturer.

INSERTING THE PRODUCT LABELS

The menu and instruction labels are supplied with the machine and must be inserted at the time of installation according to the layout and to the language (see "selection dose" table).

To access the label insertion slots, remove the side cover of the door, secured with two screws.

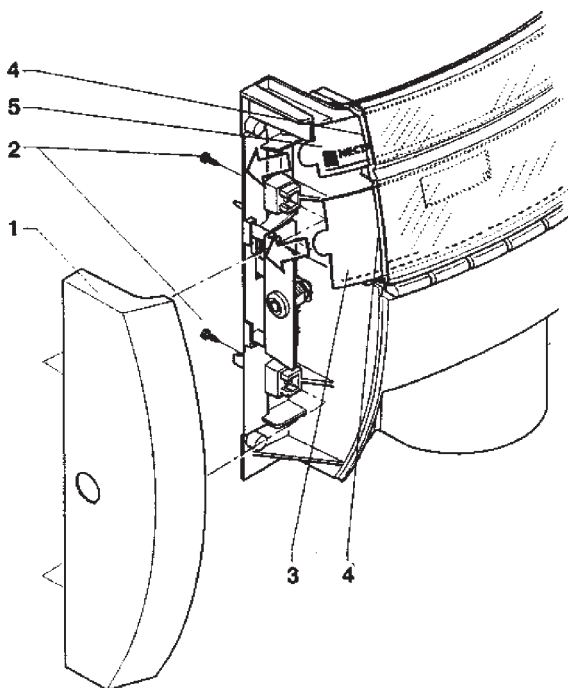

Fig. 17

- 1 - Side cover
- 2 - Fastening screws
- 3 - Selection menu label
- 4 - Slots for inserting the labels
- 5 - User instruction label

SWITCHING ON

Before switching the machine on, ensure that the grounds trays and the container lids are into place.

Each time the machine is energised, the display presents the list of controls to be performed before starting the machine, and namely:

Close top panel

Tubing (nozzles etc.)

Mixers

Powder feeder

Switching on

SWITCHING ON
Confirm?

For all controls the request "Confirm?" is indicated on the display.

Press any selection button to continue.

The function of presenting the list of preliminary controls can be disabled from the programming menu.

At the end of the switch on cycle, the display indicates the software version number to which referring for consulting the programming manual.

Koro FB
REV 1.0

The machine can be programmed for displaying, for a few second, the number of selections made.

After a few seconds the display shows the message:

Ready for use
SELECT THE DRINK

INITIALISING

When the “Initialise” function is displayed the vending machine can be initialised restoring all default data.

This function should be used the first time the machine is switched on and in the event of a memory data error or reprogramming of the board.

All statistic information will be reset.

Press confirm button “#” and the display will indicate the message “Confirm?”. Press the button “##” again to display the first variable parameter to define the machine configuration.

The available options (blinking) can be scrolled with the “##” and “##” buttons, the selection is confirmed with button “##” and the next parameter is presented. When pressing button “#” after the last parameter the display will show the message “Working” for a few seconds and the machine is initialised.

The parameters are as follows:

“Country”	Type of doses to be used for the selections
“Layout”	Layout of containers and selection menu from the available ones
“Tank”	Water supply from the mains or from a tank

FILLING THE WATER SYSTEM

When the machine is switched on the conditions of air-break (full or empty), pump and boiler priming (pressure) are checked.

If required by the conditions, the machine will automatically start an installation cycle, and namely:

- the message “Installation” will be shown on the display for the entire duration of the cycle;
- the water mains solenoid valve is opened or the pump is started to fill the air-break;
- the milk solenoid valve is opened so that the air may be bled from the boiler and water is filled.

N.B.: If there is no water flow from the mains during the installation cycle, the machine will stop until water is resumed or the machine is switched off.

IMPORTANT NOTICE!!!

If a considerable amount of air bubbles is formed in the water system, for example during maintenance, it is possible that an installation cycle is automatically started when the machine is switched on.

Versions with internal tank

For models with an internal tank, when the machine is first switched on, the installation procedure MUST BE carried out manually (see relevant chapter).

BREWER UNITCYCLE

After each time the machine is switched on the brewer unit performs a control cycle to check the correct functioning of the piston stroke, filter closure and scraper stroke to ensure that the device is in the correct initial position.

When making a selection, the filter holder closes to seal the brewing chamber.

The product dose is dispensed and part of the water dose is sent from the pump located on the boiler lid, through the dispensing solenoid valve, to the brewing chamber.

The piston advances, applying pressure in the chamber and closing the upper valve of the brewer.

Then the drink is dispensed.

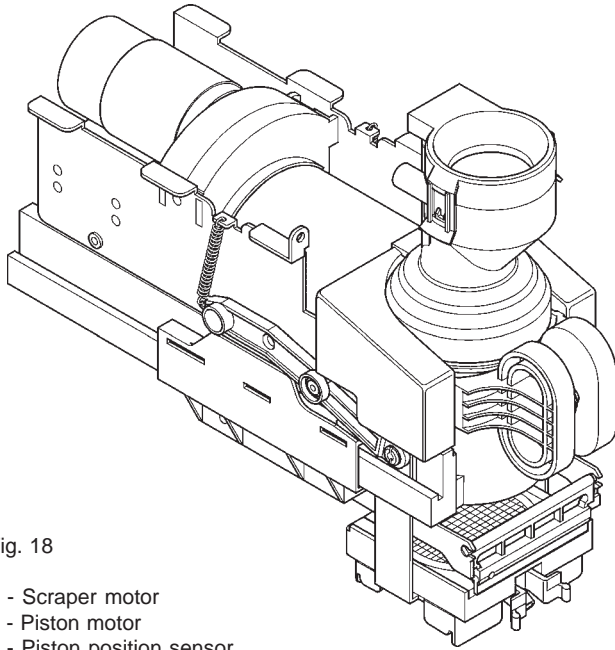
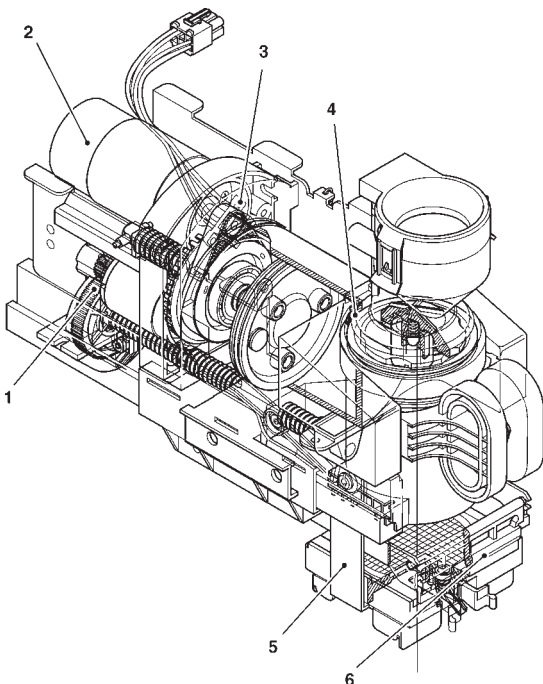

Fig. 18

- 1 - Scraper motor
- 2 - Piston motor
- 3 - Piston position sensor
- 4 - Brewer closing valve
- 5 - Filter holder
- 6 - Scraper



At a (programmable) brewing time, the piston returns and advances again, performing a wash cycle of the product loading zone and completing the brewing cycle; the piston remains in position for a programmable drying time.

At the end of the drying period, the scraper motor is started, opening the chamber and expelling the used grounds.

The piston and the scraper return to the initial position.

According to the type of selection made, the flow diverting solenoid valve will send the drink to the external nozzle or to the dispensing spout, which has the function of limiting the brewing pressure into the cup.

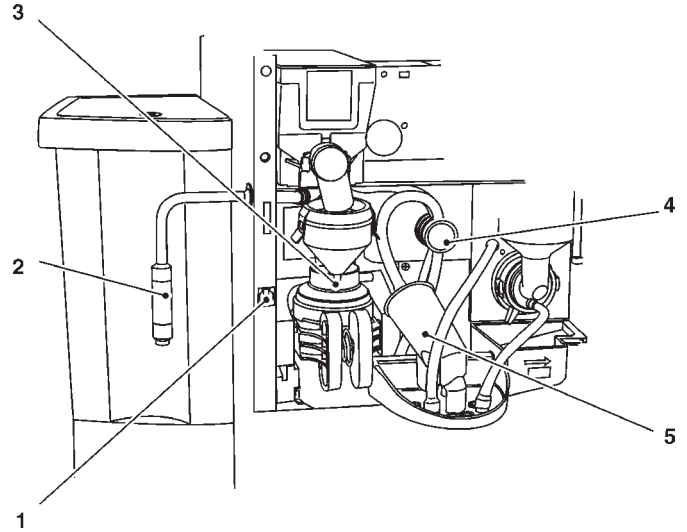

Fig. 19

- 1 - Door switch
- 2 - Jug filling nozzle
- 3 - Brewer unit
- 4 - Flow diverter solenoid valve
- 5 - Dispensing spout

CHECKING AND ADJUSTING THE MACHINE SETTINGS

To get the best results from the product used, the following should be checked:

The dose weight of the instant products.

The drink temperature.

The water dose.

Should the standard settings need to be changed, proceed as indicated in the next sections of this manual.

The weight of products, the water dose and temperature are directly controlled by the microprocessor.

To adjust them it is therefore necessary to follow the programming procedures.

Notes on programming

The machine electronic control allows or not the use of many functions:

All of the available functions are described in the machine program, including the ones that are not used for the specific configuration of the model (layout).

The machine is supplied with a dose table, describing the different functions and layouts available for the specific model and the flowchart of the programming menu.

Below is listed a summary explanation of the main functions useful for managing the operation of the machine, not necessarily in the order in which they are displayed in the menu.

For further information and detailed explanations refer to the programming manual available through our sales organisation or at our after-sales service.

The software version can be updated using the specific systems (PC, Flash, Upkey etc.).

The messages on the display that indicate the current operation are fixed, while any action required by the user is blinking.

SWITCHING ON

When closing the door, the display indicates the software version number to which referring for consulting the programming manual. The machine can be programmed for displaying, for a few second, the number of selections made.

After a few seconds the display shows the message: and the machine goes into normal operating mode



OPERATING MODES

The machine can be in three different operating modes. According to the operating mode, the buttons take on different functions.

The available operating modes are as follows:

	FUNCTIONS
Normal operating mode	coins accepted products dispensed
Filler menu	test dispensing machine maintenance
Technician menu	programming the different parameters

NORMAL OPERATING MODE

During the normal operating mode the display shows the message for the user with the prompt to select the drink. The function of the buttons can be different according to the layout and to the choices made during programming.

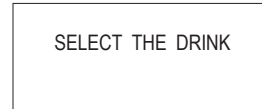

When inserting coins or a payment system, the available credit is displayed.

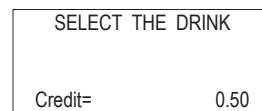

During the drink dispensing, also a status bar is shown, indicating the drink preparation status.



In the event of a malfunction detected by the control system, an error message will be displayed indicating the type of problem.

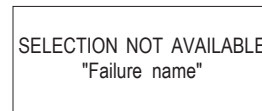

At the end of dispensing, the display indicates for a few seconds the request to pick up the drink and the machine is preset for the next selection.

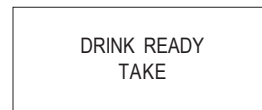

SURFING MODE

The interaction between system and user occurs through the following components:

- Liquid crystal display (LCD) 2 lines of 16 characters.
- External direct selection push-button panel which takes on the following functions when in “Filler” and “Technician” mode (see Fig. 20):

Fig. 20

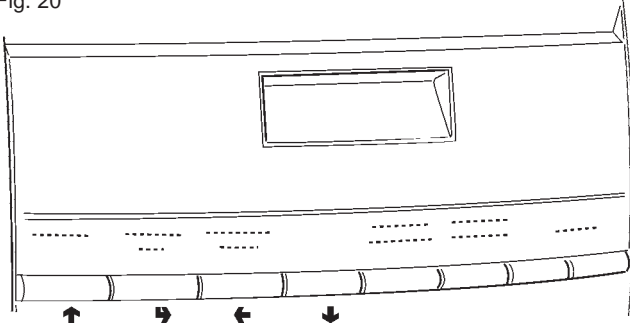

Scrolling buttons “↑” and “↓”:

To move to the next or previous menu option and change the values (up or down).

Confirm button “→”:

To move from a menu to a sub-menu or it is used to confirm the current information on the display.

Exit key “←”:

to return from a sub-menu to the higher level menu, or to clear the data on the display.

It is also used for going from “Technician” mode to “Filler” mode and vice versa.

FILLER MENU

When pressing once the programming button located on the push-button card, the machine goes into “Filler menu” mode.

Fig. 21

- 1 - RS232 serial port
- 2 - Wash button
- 3 - Programming access button
- 4 - Push-button card cover

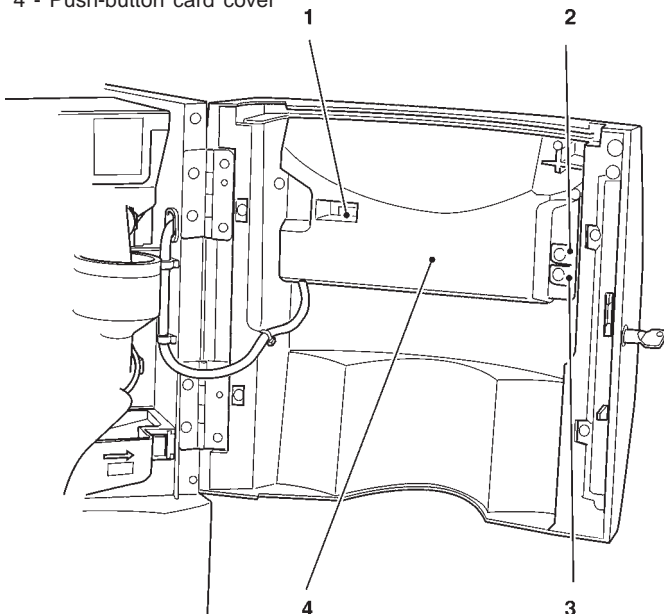

The display presents the first item of the “filler” menu with a series of numbers next to it, identifying the level of the current menu.

Press the confirm button “→” to access the menu.

Press the exit button “←” to return to the previous menu.

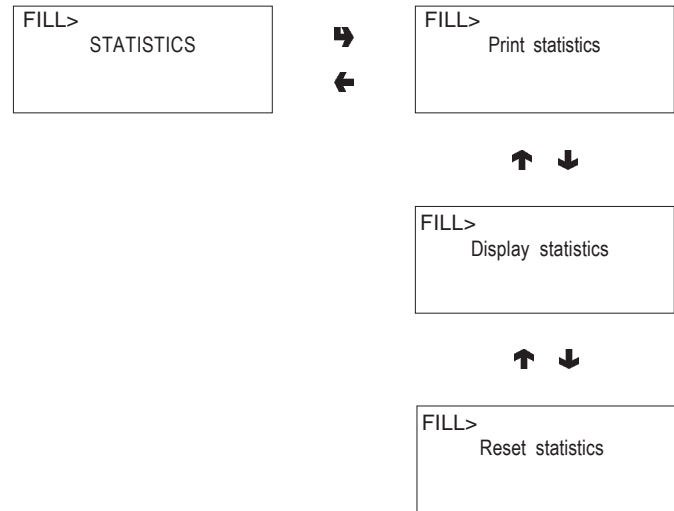

STATISTICS

All data concerning sales and the machine operations is stored in both total counters and relative counters, which can be reset without losing total data.

Print

Connect an RS232 serial printer having a Baud rate of 9600, 8 data bit, no parity, 1 stop bit to the serial port located on the push button board to print all of the statistics.

The printout will also contain the machine information, the date and the software version.

To connect the printer, do as follows:

- press the confirm print button “→”, displaying the message “Confirm?”;
- connect the printer before confirming;
- press the confirm button “→” to start printing.

Display

Press the confirm button “→” to display in a sequence the same data obtained with the statistic printing, for both total and relative counters.

Delete

Statistics can be reset for relative counters globally (all types of data) or selectively for:

- selections
- failures
- coin mechanism data

Press the confirm button “→”, and the message “Confirm?” starts blinking.

Press the confirm button “→”, the message “Working” is displayed for a few seconds and all statistics are reset.

SELECTION PRICES



This function is used for changing the sales price for each single selection and for each time band that may be set.

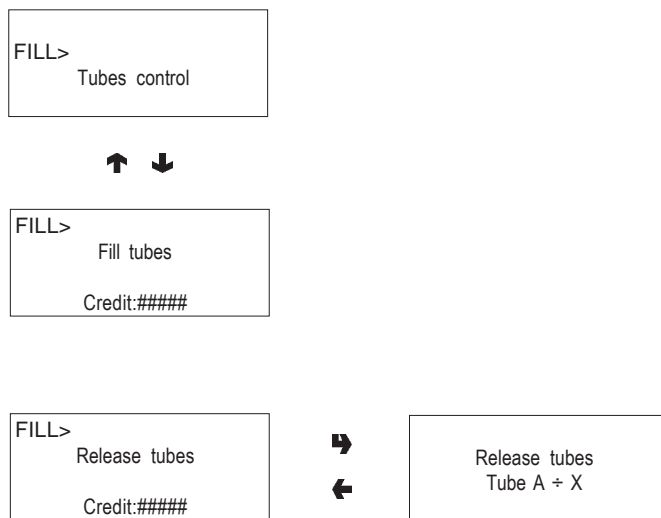

CHANGETUBESCONTROL

By accessing the “Tube control” function the change tubes can be filled or released manually.

Confirm refilling, and the display will indicate “Credit: —” which is the value of money available in change the tubes; insert the desired coin into the validator and the display will indicate the value of money available in the change tubes.

When confirming releasing, it will be possible to decide which tube to release. Each time the confirm button “➡” is pressed, a coin is ejected from the active tube.

DISPLAYING THE TEMPERATURE



With this function it is possible to read the boiler temperature directly in °C.

The symbol “○” indicates that the boiler heating element is not heating.

The symbol “●” indicates that the boiler heating element is heating.

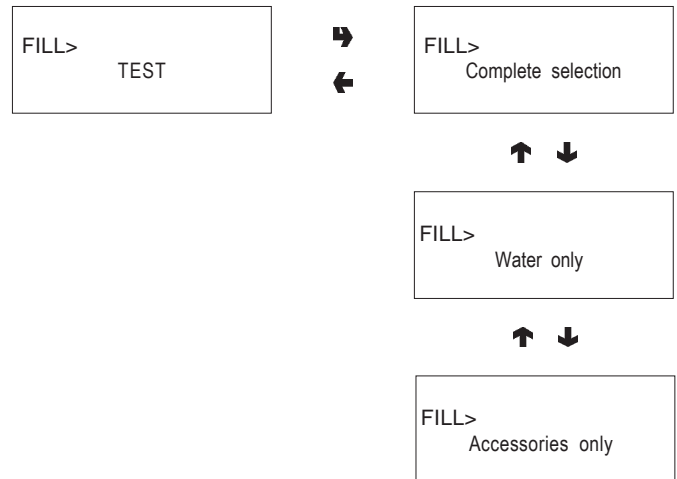

TEST DISPENSING

For complete or partial dispensing tests (water, powder, only and without accessories) each button (or combination of buttons according to the model) is assigned a selection (see the dose selection table).

N.B. For espresso coffee based selections, only the additions are dispensed with the partial dispensing of powder and water; if a selection requires no addition the message “Sel. disabled”, indicating a disabled selection, will be displayed.



GSM PRE-ALARMS

The control software can send, via GSM modem, a signal indicating an “ending product” signal, when there is only a certain (programmable) number of pieces or grams of powder of a given product left. With this function the counters that control the pre-alarms are reset.



EVADTS TRANSFER

When activating this function, the machine awaits the connection with a device to acquire the EVADTS statistics.

FILLER MENU MASKING

The functions described in this chapter can be inhibited selectively from the “technician menu”.

TECHNICIAN MENU

Below is listed a summary explanation of the main functions useful for managing the operation of the machine, grouped by use logic and not necessarily in the order in which they are displayed in the menu.

The software version can be updated using the specific systems (PC, Flash, Upkey etc.), therefore all is described in this chapter is only to be taken as an example.

For further information and detailed explanations refer to the dose selection table supplied with the machine and to the programming manual available through our sales organisation, at our after-sales service or directly in the internet, referring to the version number that is displayed when switching on the machine.

When pressing once the programming button located on the coin mechanism compartment, the machine goes into "Filler menu" mode.

When pressing button "←" from "Filler" mode, the machine is preset to "Technician menu".

Note:

When pressing button "←" from "Technician" mode, the machine returns to "Filler menu" mode.

The first option of the programming menu is displayed, enabling the following functions:

FAILURES

The machine is equipped with various sensors for monitoring the different functional units.

When a malfunction is detected, a failure is "indicated" and the machine (or part of it) is placed out of service. The failure is stored in the appropriate counters.

The failure monitored by the software may regard functional units not present in the specific model; they are in any case listed when scrolling the menu.

The possible failures are indicated in the following cases:

No water

If the air-break micro-switch is closed for more than one minute, the water inlet solenoid valve will remain energized until the water flow is restored.

If the machine is equipped with an internal water supply tank the pump will be switched off.

Waste container full

The machine locks if the liquid waste container float is triggered.

Air-break

The machine is locked if after 10 selections the micro-switch has never signalled the lack of water.

Volumetric counter

Failed computation of the volumetric counter (flow-meter) within a max. given time.

Boiler

The machine will lock if after the maximum time of heating from the machine start, or from the last selection, the boiler fails to reach the operating temperature.

CAN-BUS board

Failed dialogue between C.P.U. board and can-bus board (FB unit control).

Coin mechanism

The machine is locked if it receives a pulse longer than 2 seconds on a validator line or the communication with the serial coin mechanism does not take place for more than 30 seconds (Executive protocol) or 75 seconds (BDV protocol).

Grinder blockage

If the coffee grinder does not rotate or rotates too slowly for longer than 5 seconds, the espresso coffee selections are disabled. Decaffeinated based selections remain available.

Espresso unit

Due to mechanical blocking of the unit.

The machine is not locked, but all coffee-based selections are disabled.

No coffee

If the coffee grinder exceeds the grinding speed for longer than 5 seconds, the espresso coffee selections are disabled. Decaffeinated based selections remain available.

RAM Data

One or more areas of the RAM contain wrong data which was corrected with the default values.

The machine will continue to function, but it would be advisable to initialise as soon as possible.

Fresh-brew piston

Due to wrong positioning of the unit.

The machine is not locked, but all fresh product based selections are disabled.

Fresh-brew scraper

Wrong positioning of the grounds ejection scraper.

The machine is not locked, but all fresh product based selections are disabled.

Cold unit pressure switch

In the event of lack of pressure from the mains, the cold drinks selections are disabled.

No syrup 1 and 2

Locking the relevant selection in the event of lack of syrup.

Empty carbonator

If the level control device of the carbonator indicates it is empty, cold drink selections are placed out of service.

Cold unit compressor

The machine is locked if the cold unit temperature sensor does not signal a temperature change in 40 hours.

Cold unit card

If there is communication between the cold unit card and the CPU board the cold drink selections are disabled.

READING PRESENT FAILURES

When the "Failure" function is displayed, press the confirm button "↵" to display the present failures.

If no failures are currently present, after pressing the confirm button "↵" the message "End failures" will be displayed.



RESET

By confirming this function all current failures will be reset.



PROGRAMMING PARAMETERS

CASH

This set of functions controls all parameters regarding the payment systems and the sales prices.

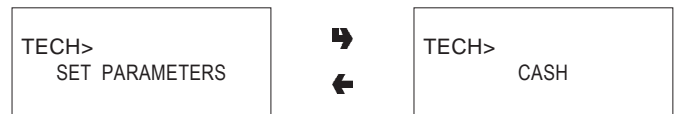

Selection prices

Four different prices can be set for each selection according to the programmed time bands for when the time table option is enabled.

For each of the 4 time bands prices (0 to 65,535) can be programmed globally (same price for all selections) or for the single selections.

Should the majority of products be sold at the same price, it will be convenient to set the price globally and then change the figure of the selections with different prices.

Time bands

Four programmable time bands are provided for selling products at different prices.

The time periods are programmable for beginning and end time by hours (00 to 23) and minutes (00 to 59).

If the values for start and end of the time band are set to 00.00 the time period is disabled.

The reference time is kept by an internal clock, programmable as:

day/month/year week-day 1-7

and then

hour/minutes/seconds.

If the values for start and end of the time band are set to 00.00 the time period is disabled.

Coin mechanisms

It is possible to decide which of the payment system protocols available are to be enabled for the functions.

The available payment systems are:

- Executive
- Validators
- BDV
- MDB

By selecting one of the systems it is possible to control its functions.

Executive

The following payments systems are available for the Executive system:

- Standard
- Price Holding
- Coges
- U-Key
- Sida

Validators

When the "Validat. Lines" (line setting) function of the "technician" menu is displayed, the value of the 6 validator coin lines, A to F, can be changed.

BDV

The BDV protocol menus are used for defining the following functions:

- Type of vending
- Change control
- Maximum credit
- Maximum change
- Accepted coins
- Not accepted coins
- Dispensing buttons
- Value of "exact amount"
- C.P.C. device
- Minimum level of tubes

MDB

The MDB protocol menus are used for defining the following functions:

- Type of vending
- Change control
- Maximum credit
- Maximum change
- Accepted coins
- Returned coins
- Accepted bills
- Minimum level of tubes
- Accepted coins with "exact amount"

For further information refer to the programming manual.

FUNCTIONS COMMON TO ALL SYSTEMS

Immediate change

Normally, the amount of a selection is cashed after the machine sends the message "Selection successful". When this function is enabled, disabled by default, the cash message is sent at the beginning of dispensing.

Decimal point

Press the confirm button "➡" to display the position of the decimal point, i.e.:

0	decimal point disabled
1	XXX.X
2	XX.XX
3	X.XXX

Press the confirm button "➡", these values will start blinking and can then be modified as necessary.

SELECTIONS

The selection menu is composed of various sub-menus which allow setting of the different parameters regarding the composition of selections and to which buttons they are to be associated.



Water dose

The water dose (expressed in cc - FB - IN or “flow-meter pulses” according to the models) can be set for each selection button and therefore for each product assigned to such selection.

Whipper Control

The whipping time can be set for each selection button, for each water dose that composes such selection. The duration can be set in two different modes:

Absolute

i.e. independent from the solenoid valve opening time. The whipping duration is set as tenths of a second for Instant models and as volumetric counter pulses for Espresso models.

Relative

i.e. based on the difference, plus or minus, from the moment the solenoid valve closes. The whipping duration is always expressed in tenths of a second.

Solenoid valve settings

It is possible to set (IN - FB) the water flow rate of the single solenoid valves expressed in cc/s (the default value setting in cc/s is indicated in the selection dose table) to calculate the amount of water to be dispensed.

Powder dose

The powder dose expressed in grams can be set for each selection button, for each product that composes such selection. For correct conversion of product dose values, the flow rate of the single doser units, expressed in g/s, can be set to calculate the amount of powder to be dispensed. It also possible to program the doses of a product “Globally”, i.e. setting the powder of all selections using it with a single operation.

Selection status

Each single selection button can either be enabled or disabled.

Button-Selection

Permitting the association of a selection number, indicated in the the selection dose table, to a button in the direct selection keypad.

Checking selection number

Verifying the selection number associated to a button.

VENDING MACHINE PARAMETERS

This group of functions controls all parameters concerning the machine operation.



Boiler temperature

This function is used for setting the operating temperature of the boiler, expressed in °C. After selecting the boiler, press the confirm button “↵”, the temperature value on the display will start blinking and can be modified as necessary.

Tank

The machine water supply can be from the mains or from an internal tank. With this function it is possible to define whether the machine water supply is from the mains (tank = 0) or from the tanks (tank = 1).

Enabling the wash button

With this function it is possible to enable the operation of the mixer wash button. Normally the button is disabled.

Mixer heating

If the function is enabled and no selections were made in the last 3 minutes, a small amount of hot water is dispensed into the milk or instant coffee mixers before dispensing short instant coffee, instant coffee with milk and espresso coffee with milk.

Fast cycles

When this function is enabled, some of the time that is useful for improving the drink quality is eliminated.

- all of the products that compose the drink are dispensed at the same time;
- the “post-whipping” time is eliminated.

Setting the regeneration counter

It is possible to display the message “Regenerate the water softener” upon accessing “filler” mode after a programmable number of drinks dispensed.

Automatic wash

Option of setting the time when automatically cleaning the mixers and rotating the brewing units installed. When setting the time to 24.00 the function is disabled (default).

Energy saving

In order to save electric power when the machine is not in use, this function is used to switch off boiler heating and/or external lighting.

2 switch-off time bands can be programmed on a weekly basis; the week days are identified by a progressive number (1=Monday, 2=Tuesday etc.).

The same time band cannot include days from different weeks.

If time bands are set overlapping, the machine will remain switched on for the shorter period.

For example, in order to set energy saving time bands to run the vending machine from 07.00 to 22.00 during the week and leave it switched off on the weekend, the time bands should be set, using the special menu, as indicated in the table below.

Day		1	2	3	4	5	6	7
band 1	start	00.00	00.00	00.00	00.00	00.00	00.00	00.00
	end	07.00	07.00	07.00	07.00	07.00	23.59	23.59
band 2	start	22.00	22.00	22.00	22.00	22.00	00.00	00.00
	end	23.59	23.59	23.59	23.59	23.59	00.00	00.00

Decaffeinated cycle

When enabling this function, instant coffee powder (if present) is dispensed in two steps to improve the appearance of the drink.

DISPLAY

This group of functions controls all parameters concerning the display indications.



Language

There is an option of language, selected among the ones available in the software, to be used for the messages on the display.

Promotional message

It is possible to define whether or not the message is to be displayed.

The 2-line message can be written using the “↑” and “↓” buttons to scroll through the available characters.

Press the confirm button “→”, the first character will start blinking and can be modified.

The message is stored by pressing button “←”.

PRE-SELECTIONS

This function is used for setting the pre-selections, associated to each single selection, present in the specific model and layout.



For each pre-selection it is possible to decide whether or not it is to be enabled, which button will be assigned to, the selection price change and the percentage change in product dose.

MISCELLANEOUS

This menu contains some of the functions that are used less frequently concerning the machine parameters.



Fresh-brew unit data

For the Fresh-brew unit it is possible to set the brewing time, the drying time for the used dose and the extraction pressure.

Jug Facilities

Some models, supplied with a special button, permit dispensing of a number of selections (programmable between 1 to 9; 5 as default) without cup to fill a jug.

Password

It is a 5-digit numeric code which is required to access programming.

The default value of this code is set to 00000.

Enabling the password

This function is used to enable the option of requesting the password to access programming; the password request is disabled by default.

Enabling the Filler menu

This function is used to determine the filler menu options to be left active or to be disabled.

The reference numbers of the menus do not change even if some are disabled.

STATISTICS

Data on the machine operations is stored in both general counters and relative counters, which can be reset without losing total data.



Electronic counter

An electronic counter stores the total of all selections made since the last reset.

Displaying general statistics

When pressing the confirm button “

- 1 - single selection counter;
- 2 - counter by time bands;
- 3 - discount counter;
- 4 - failure counter;
- 5 - coin mechanism data.

Resetting general statistics

Statistics can be reset either globally (all types of data) or partially for:

- selections
- discounts/overprice
- failures
- coin mechanism data

Press the confirm button “

Press the confirm button “

Displaying relative statistics

When pressing the confirm button “” the stored data is sequentially displayed with the same subdivision of the general statistics.

Resetting relative statistics

Statistics can be reset either globally (all types of data) or partially as in the general statistics.

Enabling the counters at start-up

This function is used to enable/disable the display of the total number of sales since the last statistic reset, during the start-up phase of the machine.

Printing

Connect an RS232 serial printer having a Baud rate of 9600, 8 data bit, no parity, 1 stop bit to the serial port located on the push button board to print all the statistics described in the paragraphs “Displaying general statistics” and “Displaying relative statistics”. The printout will also contain the machine information, the date and the software version. Statistics can be printed partially or totally.

To connect the printer, do as follows:

- press the confirm print button “

TEST

This group of functions is used for performing some controls on the machine.



Test dispensing

With this function it is possible to obtain, with the door open and without inserting any money, for each selection dispensing of:

- complete selection
- water only
- powder only

Special functions

By accessing this function it is possible to:

- activate the espresso brewer unit;
- release a ground coffee dose;
- open a solenoid valve to allow the intake of air in the event of emptying the boiler for maintenance;
- manually install the boiler;
- activate the fresh-brew unit.

Autotest

This function allows testing, in a semiautomatic way, of the main machine components.

Press button “

It is possible to cancel each operation and go to the next one by pressing button “

Some checks occur automatically, others need the manual operation of the monitored component.

For the actuation sequence refer to the programming manual.

MISCELLANEOUS

This menu contains some sub-menus, used less frequently, which permit control of the functions described below.



Machine information

Installation date

This function is used to store the current date of system as installation date.

The date is printed when retrieving the statistics.

Programming the machine code

When the "Machine code" function is displayed the eight-digit numeric code identifying the machine can be changed (from the default 0).

Programming the operator code

When the "Operator code" function is displayed the six-digit numeric code identifying groups of machines can be changed (from the default 0).

Initialising

When the "Initialising" function is displayed the vending machine can be initialized restoring all default data.

This function should be used if there is a memory data error or when the software is replaced.

Except for the general electronic counter, all statistical data is reset.

Press confirm button "↵" and the display will indicate the message "Confirm?". Press the confirm button "↵" again and some parameters will be requested, which are:

"Country"

intended as type of base doses for the different selections (e.g. IT coffee = 45 cc - FR coffee = 80 cc).

The available "countries" vary according to the models.

"Layout"

A number of Button/Selection combinations to choose from is provided for each model and dose type (the combinations available for each layout are indicated in the dose selection table supplied with the machine).

"Tank"

Defining whether the water supply is:

ON - from a tank

OFF - from the mains

When confirming the options the message "Working" is displayed for a few seconds.

Adding hot water

It enables the option, in some models only, of adding or not hot water for some selections.

Chapter 3 MAINTENANCE

Important notice!!

Access to the machine interior for maintenance and/or repairs is via the side panels.

Therefore the machine is designed to be rotated, thus allowing removal of the sides and of the back panel.

The integrity of the machine and compliance with the standards of the relevant systems must be checked at least once a year by qualified personnel.

With the main switches turned off, the terminal strip connected to the line cable, the fuses and the noise suppressor stay energised in any case.

Before starting any maintenance operations requiring parts of the unit to be removed, the machine must always be switched off.

The operations described below must be carried out only by personnel who have the specific knowledge of the machine functioning from a point of view of electrical safety and health regulations.

INTRODUCTION

To ensure correct operation for a long period, the machine must be subjected to regular maintenance.

The following sections contain the procedures and the maintenance schedule, which are only a general indication, as they greatly depend on the operating conditions (e.g. water hardness, environmental humidity and temperature, type of product used, etc.).

The procedures described in this chapter are not exhaustive of all maintenance operations to be carried out.

More complex operations (e.g. boiler descaling) should be carried out by qualified technicians only having specific knowledge of the machine.

To prevent oxidation or the action of chemical agents, the stainless steel and varnished surfaces should be kept clean by using mild detergents (solvents must not be used).

Under no circumstances should water jets be used to clean the machine.

SANITISING THE MIXERS AND FOODSTUFF CIRCUITS

When installing the machine, and then at least once a week or even more frequently according to the use of the machine and the quality of the inlet water, the mixers and the dispensing conduits must be thoroughly sanitised (cleaned and disinfected), to guarantee proper hygiene of the dispensed products.

The parts to be cleaned are as follows:

- powder deposit drawers, mixer and instant drink dispensing conduit;
- dispensing spouts;
- spout support tray;
- remove the powder and the water funnels, the feeders, the powder deposit drawers and the mixer wheels from the mixers (see Fig. 23);
- in order to remove the water funnel the green ring nut must be rotated anticlockwise;

pay special attention to closing it fully during reassembly;

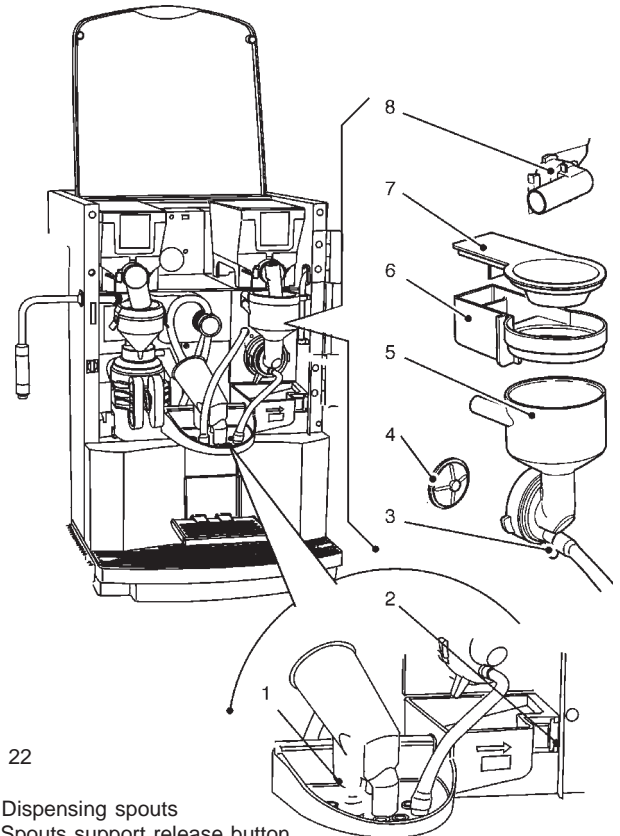

Fig. 22

- 1 - Dispensing spouts
- 2 - Spouts support release button
- 3 - Funnel securing ring nut
- 4 - Mixer impeller
- 5 - Water funnel
- 6 - Powder deposit box
- 7 - Powder funnel
- 8 - Powder dispensing pipette

- in order to remove the impellers, block the disk fitted on the mixer shaft with a finger (see Fig. 23).

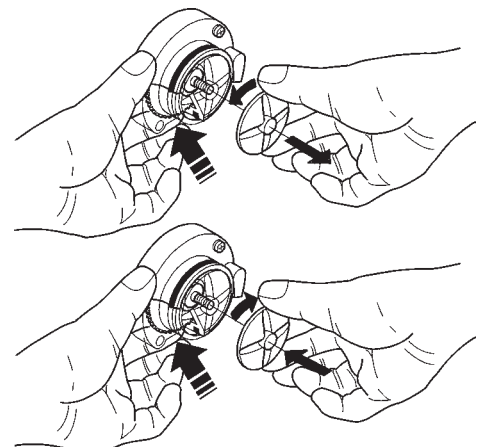

Fig. 23

Wash all parts with detergent being sure that all visible residue and product layers are mechanically removed, using a brush if necessary.

Disinfection should be carried out using sanitising products.

- soak all components for approx. 20 minutes in a container filled with the previously prepared sanitising solution;
- reinstall the feeders and the water funnels;
- reinstall the powder deposit drawers and the powder funnels after thoroughly drying them.

After reinstalling all parts the following is however required:

- add a few drops of the chlorine-based detergent in the mixer;
- using the mixer cleaning function with the door closed, thoroughly rinse all components to ensure that all residue of the detergent solution is removed.

REGENERATING THE SOFTENER UNIT (OPTIONAL WITH BASE CABINET)

A 2-litre ion-exchange resin softener unit can be used on these machines.

The resins should be regenerated at least once a week or even more frequently depending on the hardness of the water from the mains used to supply the machine (see table below).

Water hardness		N. of selections	
°fH	°dH	60 cc.	130 cc.
10	5.6	5600	2800
20	11.2	2800	1400
30	16.8	1900	900
40	22.4	1400	700
50	28.0	1100	550

To regenerate the resins correctly do as follows:

- remove the softener unit from the cabinet and shake it vigorously to eliminate any preferential paths which may have formed;
- fill 0.5 Kg. of sodium chloride (ordinary table salt);
- connect the side hose union to a tap and the middle rubber-holder to a drain point;

NECESSARILY

the one shown in figure 24

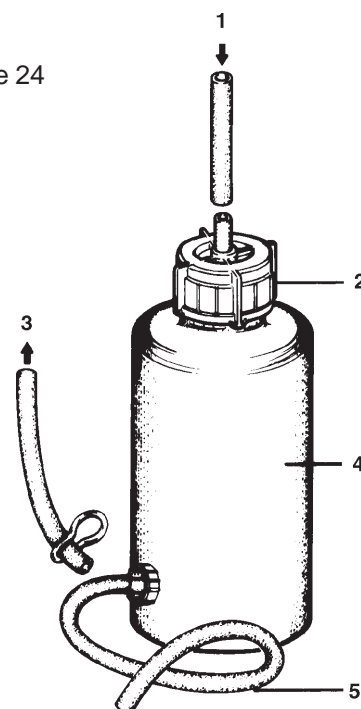

Fig. 24

- 1 - From the tap
- 2 - Cap
- 3 - To the machine
- 4 - Softener unit
- 5 - To the drain

- adjust the water flow in such a way as to completely dissolve the salt in 10 litres water within 25 minutes;
- during the regeneration operation, ensure that the softener unit is always full of water, bleeding any air which may have entered;
- at the end of this operation ensure that outlet water is no longer salted; it is advisable to check the hardness of the water by means of appropriate chemical reagents, the outlet water hardness should be 0°fH.

MAINTENANCE OF THE BREWER UNIT

As well as cleaning every week and/or every 1,000 selections, the brewer filter and gasket must be replaced every 25000 selections, even if apparently still efficient.

Every 100,000 selections the brewer unit must be disassembled completely to thoroughly clean all parts and replace the worn ones.

Important notice!!

Should the unit need to be removed completely, it must not be held by the cylinder or by the filter holder.

MAINTENANCE OF THE BOILER

According to the hardness of the water and the number of selections made, a periodic descaling of the boiler is necessary.

This operation should be carried out by qualified technicians only.

To descale the boiler, it is necessary to remove it from the machine.

For descaling use only biodegradable, non-toxic and mild products.

Thoroughly rinse all parts before reassembling.

When reassembling make sure that:

- the electrical contacts (terminals, fastons etc.) are thoroughly dry and correctly connected;
- the safety and anti-boiling thermostats are suitably positioned and fastened;
- the hydraulic connections are correctly made.

IMPORTANT NOTICE!!!

If for any reasons the heating system of the boiler is operating without water, check the correct functioning of the boiler temperature sensor before restarting the machine.

If dry heating continues until the safety thermostat is activated (see hydraulic system) the boiler temperature sensor will be permanently damaged and must be replaced.

FLOW DIVERTER SOLENOID VALVE

The efficiency of the brewed product flow diverter (see Fig. 26), dispensing from the spout and to the external nozzle, especially the tubes inside the clamp, must be checked periodically.

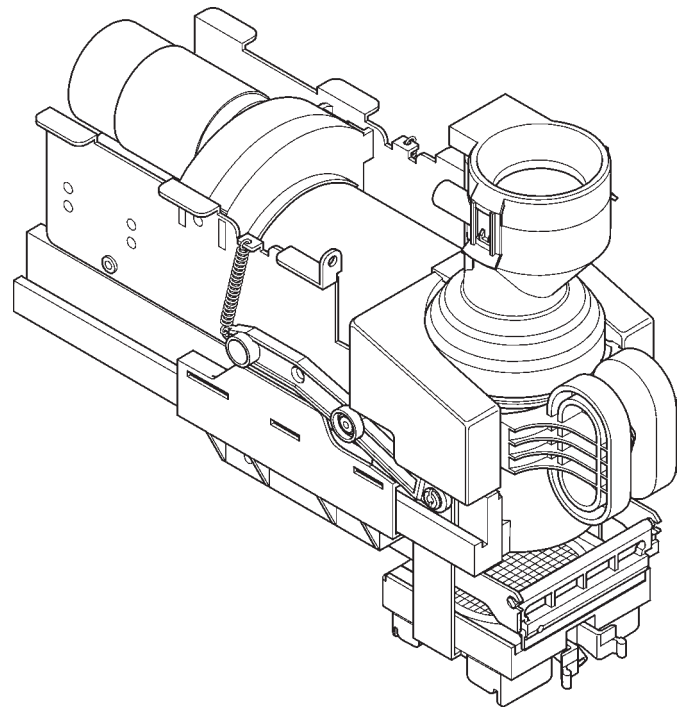

Fig. 25

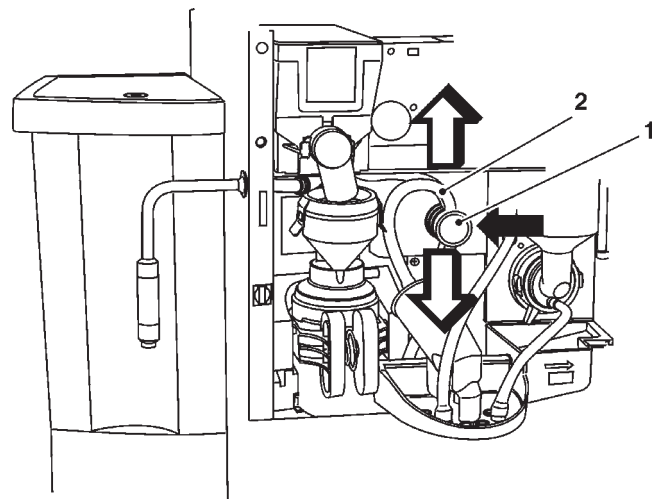

Fig. 26

- 1 - Flow diverter solenoid valve
- 2 - Silicone tubes

PERIODICAL CLEANING

At least once a year, or more frequently according to the use of the machine and the quality of the inlet water, the entire foodstuff circuit system must be cleaned and sanitized as described below.

SANITISING

- all parts in contact with food, including the hoses, must be removed from the machine and fully disassembled;
- all visible residue and product films are mechanically removed using brushes or similar tools, if necessary;
- all components must be soaked in a sanitising solution for at least 20 minutes;
- the machine internal surfaces are to be cleaned with the same sanitising solution;
- thoroughly rinse and then reinstall the parts.

Before restarting the machine, the same sanitising procedure described in section “Sanitising the mixers and the foodstuff circuits” should be repeated.

CLEANING THE PRODUCT CONTAINERS

- Remove the containers from the machine;
- undo the product ports and slide out the augers from back of the container;
- clean all parts in a solution of hot water and sanitising products and dry thoroughly.

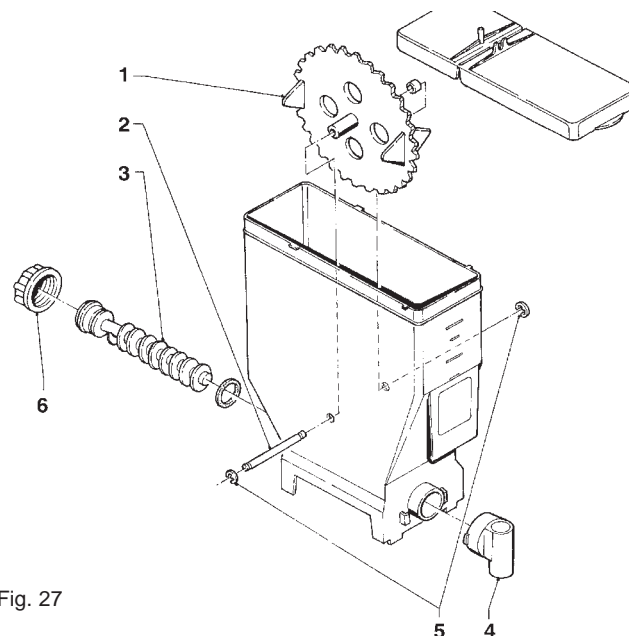

Fig. 27

- 1 - Wheel
- 2 - Wheel pin
- 3 - Auger
- 4 - Front port
- 5 - Pin snap ring
- 6 - Rear port

PRINTED BOARD FUNCTIONS AND INDICATOR LAMPS

ACTUATION BOARD

This board, placed at the back of the machine, (see Fig. 28) processes the information from the push-button card and from the payment system; it also controls the actuators, the input signals and the boiler board.

The 15 V AC voltage required for board operation is supplied by a transformer which is protected by a 125 mA T fuse on the primary and by a 1.25 AT fuse on the secondary winding. The voltage supply is rectified and stabilised directly by the board.

This board houses the Flash EPROM. The control software of the board is installed directly (via RS232) in the micro-processor.

- the red LED (7) indicates the operating status of the boiler heating element;
- the red LED (9) for resetting the CPU glows during the board reset;
- the green LED (11) blinking indicates that the microprocessor is working correctly;
- the yellow LED (12) indicates the presence of 12 V DC.

Fig. 28

- 1 - Main switch
- 2 - Mains fuses
- 3 - Boiler control board
- 4 - Brewer control board (Fresh brew version only)
- 5 - Actuation/CPU board
- 6 - Transformer protection fuses
- 7 - Transformer

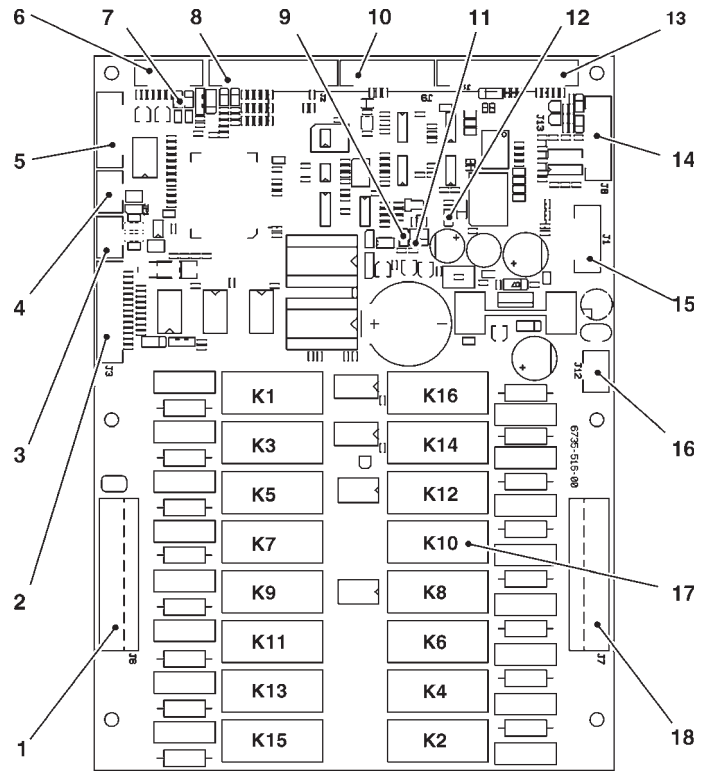
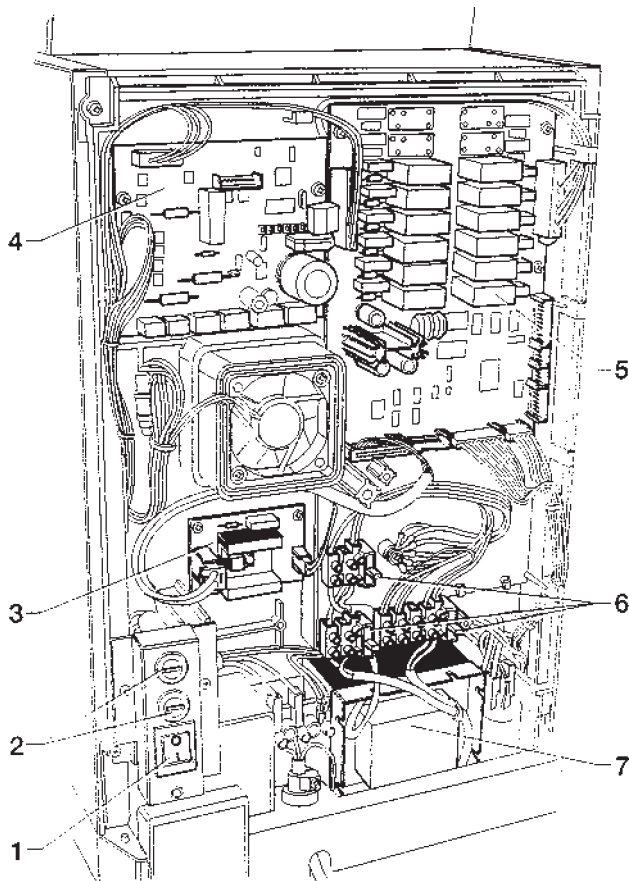

Fig. 29

- 1 - 230 V~ users
- 2 - Input signal
- 3 - Can-Bus connection
- 4 - Can-Bus connection
- 5 - Relay expansion connection
- 6 - Boiler control probe
- 7 - Red LED - boiler heating element
- 8 - Input signal
- 9 - Red LED
- 10 - Not used
- 11 - Green LED
- 12 - Yellow LED
- 13 - To the push-button board
- 14 - Connector for board programming (RS232)
- 15 - UpKey connector
- 16 - Board power supply (15Vac)
- 17 - Relays K1-K16
- 18 - 230 V~ users

RELAY	FRESH BREW
K1	PM
K2	not used
K3	MF1
K4	not used
K5	EV3
K6	EVFB
K7	not used
K8	not used
K9	EV1
K10	MD1
K11	EV2
K12	not used
K13	not used
K14	EEA
K15	not used
K16	MAC-MD2

PUSH-BUTTON BOARD

This board controls the alphanumeric display, the selection buttons and the programming button (see Fig 31). It supports the coin mechanism connectors as well as the printer port.

Fig. 30

- 1 - Selection buttons
- 2 - Not used
- 3 - To mechanical counter (optional)
- 4 - To actuation/CPU board
- 5 - Input
- 6 - Display adjusting trimmer
- 7 - To display
- 8 - 12 Vdc validators
- 9 - Not used
- 10 - RS232 serial port
- 11 - Not used
- 12 - Programming access button
- 13 - Wash button

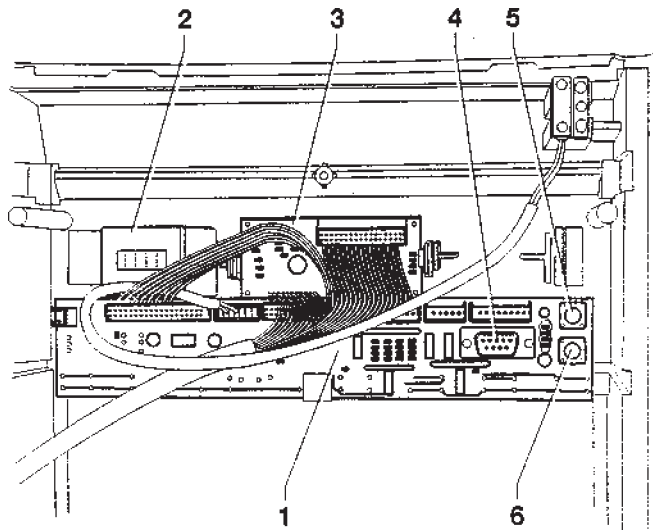
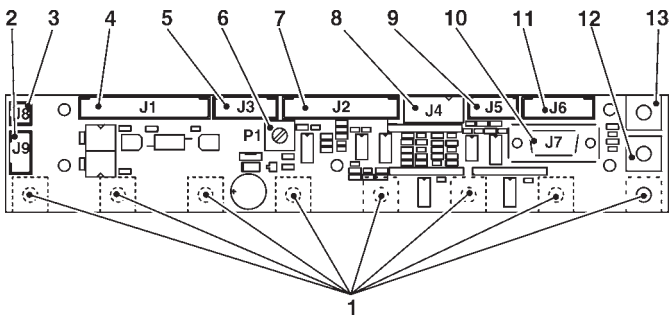

Fig. 31

- 1 - Push-button board
- 2 - Mechanical counter support
- 3 - Display card
- 4 - RS232 serial port
- 5 - Wash button
- 6 - Programming access button



BOILER CONTROL BOARD

This board (see Fig. 32) controls the boiler heating element.

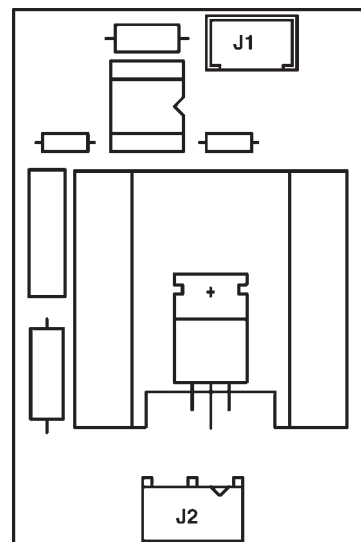

Fig. 32

SIGMA BREWER CONTROL BOARD

This board, placed at the back of the machine, (see Fig.) processes the information from the brewer unit and controls its operation.

The board also controls the dispensing of fresh product and the flow diverter solenoid valve from spout/external nozzle. The 24 V AC voltage required for board operation is supplied by a transformer which is protected by a 800 mAT fuse on the primary and by a 3.15 AT fuse on the secondary winding. The voltage supply is rectified and stabilised directly by the board.

- the green LED (7) indicates the presence of +5 V;
- the green LED (8) indicates the presence of 34 V DC variable;
- the green LED (9) indicates the presence of 34 V DC.

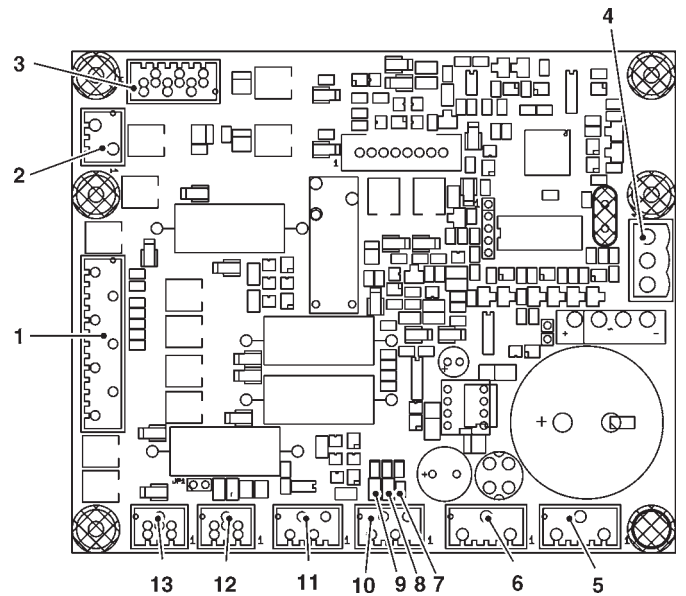
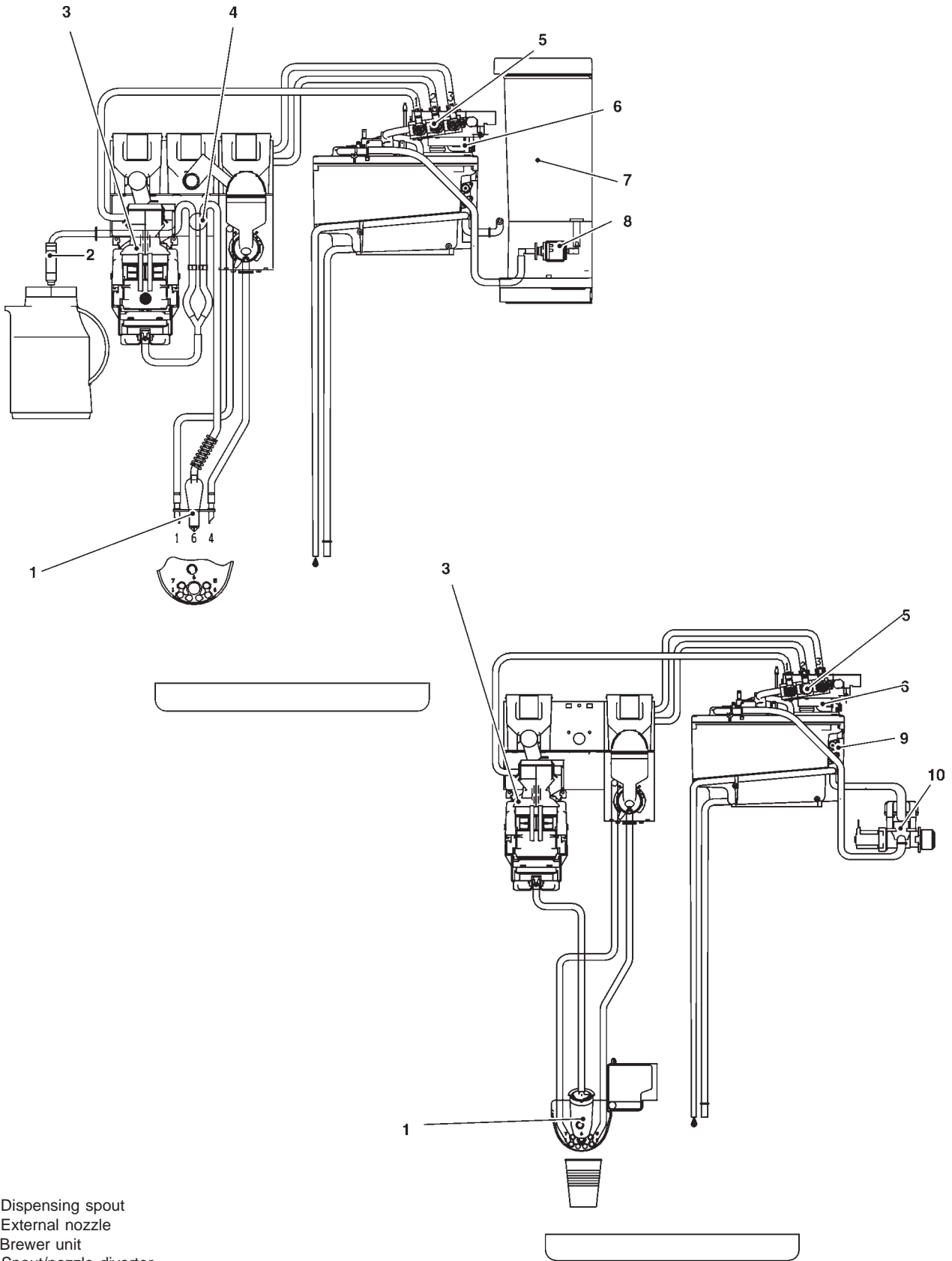

Fig. 34

- 1 - To Sigma brewer unit
- 2 - Not used
- 3 - MDFB and EVDEV
- 4 - Board power supply 24Vac
- 5 - Not used
- 6 - Not used
- 7 - Green LED +5V
- 8 - Green LED 34Vdc variable
- 9 - Green LED 34 Vdc
- 10 - Tray detection micro-switch
- 11 - Tray detection micro-switch
- 12 - Can-bus with actuation board
- 13 - Can-bus with actuation board

HYDRAULIC SYSTEM FOR FRESH-BREW



- 1 - Dispensing spout
- 2 - External nozzle
- 3 - Brewer unit
- 4 - Spout/nozzle diverter
- 5 - Dispensing solenoid valves
- 6 - Boiler pump
- 7 - External tank
- 8 - Water tank pump
- 9 - Safety thermostats
- 10 - Water inlet solenoid valve

Programming menu summary

The machine can function in 3 different operating modes.

- **Normal vending mode**
- **Filler menu**
- **Technician menu**

In order to access the programming menus, press the programming button located on the push-button card:

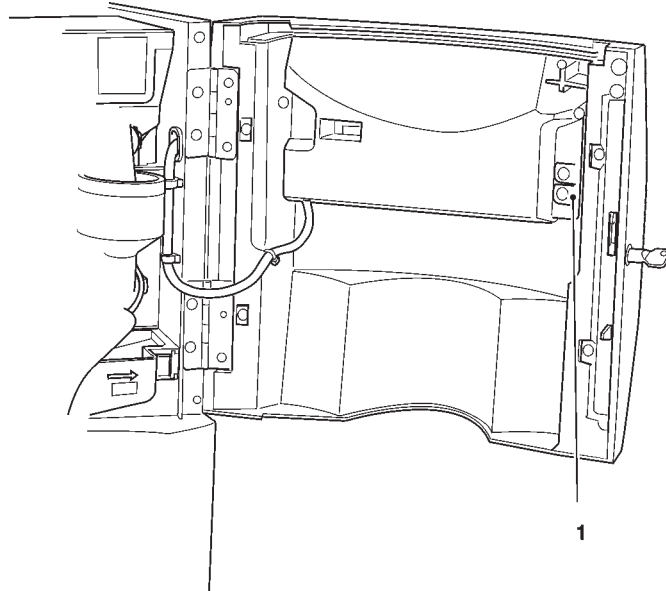

At this point the machine goes into Filler menu mode.

The buttons shown in the figure are used for surfing through the different menus:

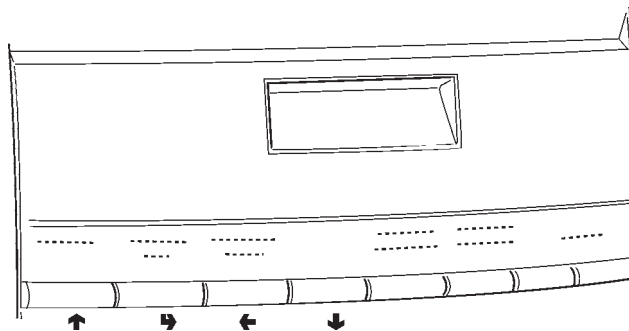

Scrolling buttons **UP** (↑) and **DOWN** (↓)

The UP and DOWN scrolling buttons are used for moving from one programming menu item to the next one, located in the same level, and at the same time change the status or the numeric value of the corresponding functions.

Confirm / enter button (↵)

The confirm / enter button is used for moving to the lower level or for confirming a value after being entered or changed.

Exit button (←)

The exit button is used for returning to the higher level or for exiting a change field of a function. When reaching the highest level in the menu, this button is pressed for going from the Technician menu into the Filler menu and vice versa.

"Filler Menu" Summary

1 - STATISTICS

1.1 - STATIS. PRINTING

1.1.1 - PARTIAL PRINTING

- 1.1.1.1 - SEL. CNT. PRINT.
- 1.1.1.2 - PRINT BAND CNT
- 1.1.1.3 - DISC. CNT.PRINT.
- 1.1.1.4 - FAIL. CNT.PRINT.
- 1.1.1.5 - COIN MECH. PRINT

1.1.2 - TOTAL PRINTING

1.2 - PRINT REL. STAT.

1.2.1 - PARTIAL PRINTING

- 1.2.1.1 - SEL. CNT. PRINT.
- 1.2.1.2 - PRINT BAND CNT
- 1.2.1.3 - DISC. CNT.PRINT.
- 1.2.1.4 - FAIL. CNT.PRINT.
- 1.2.1.5 - COIN MECH. PRINT

1.2.2 - TOTAL PRINTING

1.3 - STATIST. DISPLAY

1.3.1 - SEL. CNT. DISP.

- 1.3.1.1 - CNT DIS. X S.SEL
- 1.3.1.2 - TOT CNT DISPLAY
- 1.3.1.3 - SEL.NO.CNT. DIS.

1.3.2 - DISPLAY BAND CNT

1.3.3 - DISC. CNT. DISP.

1.3.4 - FAIL. CNT. DISP.

1.3.5 - COIN MECH. DISP.

- 1.3.5.1 - AUDIT DATA DISP.
- 1.3.5.2 - CASH COUNT. DIS.



NEXT FUNCTION/
INCREASE DATA UNIT (+1)



PREVIOUS FUNCTION/
DECREASE DATA UNIT (-1)



CONFIRM DATA /
CONFIRM FUNCTION



DELETE DATA /
EXIT FUNCTION

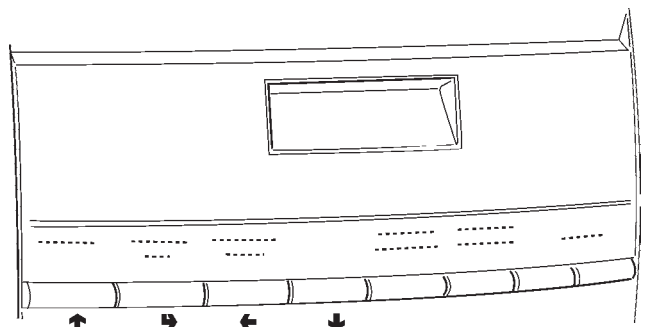

"Filler Menu" Summary

1.4 - DISP. REL. STAT.

- 1.4.1 - SEL. CNT. DISP.
 - 1.4.1.1 - CNT DIS. X S.SEL
 - 1.4.1.2 - TOT CNT DISPLAY
 - 1.4.1.3 - SEL.NO.CNT. DIS.
- 1.4.2 - DISPLAY BAND CNT
- 1.4.3 - DISC. CNT. DISP.
- 1.4.4 - FAIL. CNT. DISP.
- 1.4.5 - COIN MECH. DISP.
 - 1.4.5.1 - AUDIT DATA DISP.
 - 1.4.5.2 - CASH COUNT. DIS.

1.5 - DELETE REL.STAT.

- 1.5.1 - PARTIAL RESET
 - 1.5.1.1 - SEL. CNT. RESET
 - 1.5.1.2 - DISC. CNT. RESET
 - 1.5.1.3 - FAIL. CNT. RESET
 - 1.5.1.4 - COIN MECH. RESET
- 1.5.2 - TOTAL RESET

2 - SET INDIV. PRICE

- 2.1 - PRICE BAND 0
- 2.2 - PRICE BAND 1
- 2.3 - PRICE BAND 2
- 2.4 - PRICE BAND 3
- 2.5 - PRICE BAND 4

- | | | | |
|---|---|---|---|
| ↓ | NEXT FUNCTION/
INCREASE DATA UNIT (+1) | ↑ | PREVIOUS FUNCTION/
DECREASE DATA UNIT (-1) |
| ↵ | CONFIRM DATA /
CONFIRM FUNCTION | ← | DELETE DATA /
EXIT FUNCTION |

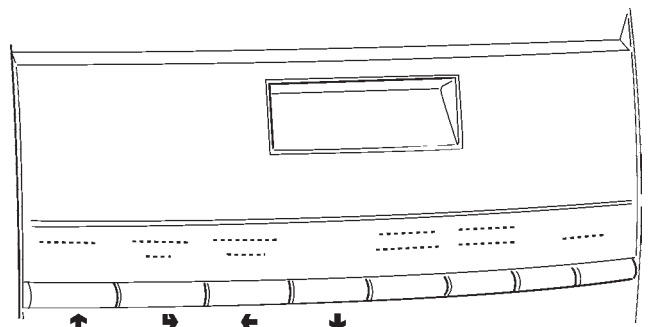

"Filler Menu" Summary

3 - TUBE CONTROL

3.1 - FILLING TUBE

3.2 - TUBE EMPTYING

4 - BOILER TEMPERAT.

5 - TEST

5.1 - COMP. DISPENSING

5.2 - WATER ONLY

5.3 - POWDER ONLY

5.4 - WITHOUT ACCESS.

5.5 - ACCESSORIES ONLY



NEXT FUNCTION/
INCREASE DATA UNIT (+1)



PREVIOUS FUNCTION/
DECREASE DATA UNIT (-1)



CONFIRM DATA /
CONFIRM FUNCTION



DELETE DATA /
EXIT FUNCTION

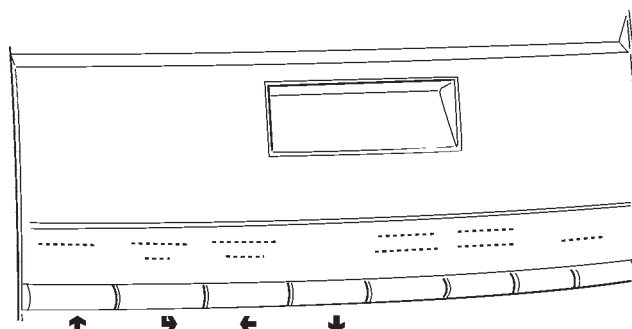

"Technician Menu" Summary

1 - FAILURES

1.1 - FAILURE READING

1.2 - FAILURE RESET

2 - SET PARAMETERS

2.1 - CASH

2.1.1 - PRICES

2.1.1.1 - SET INDIV. PRICE

2.1.1.1.1 - PRICE BAND 0

2.1.1.1.2 - PRICE BAND 1

2.1.1.1.3 - PRICE BAND 2

2.1.1.1.4 - PRICE BAND 3

2.1.1.1.5 - PRICE BAND 4

2.1.1.2 - SET GLOB. PRICES

2.1.1.2.1 - PRICE BAND 0

2.1.1.2.2 - PRICE BAND 1

2.1.1.2.3 - PRICE BAND 2

2.1.1.2.4 - PRICE BAND 3

2.1.1.2.5 - PRICE BAND 4

2.1.1.3 - TIME SCHEDULE

2.1.1.3.1 - SET DATE & TIME

2.1.1.3.2 - TIME BAND 1

2.1.1.3.3 - TIME BAND 2

2.1.1.3.4 - TIME BAND 3

2.1.1.3.5 - TIME BAND 4

2.1.2 - COIN MECHANISM

2.1.2.1 - COIN MECH. SET.

2.1.2.2 - IMMEDIATE CHANGE

2.1.3 - DECIMAL POINT



NEXT FUNCTION/
INCREASE DATA UNIT (+1)



PREVIOUS FUNCTION/
DECREASE DATA UNIT (-1)



CONFIRM DATA /
CONFIRM FUNCTION



DELETE DATA /
EXIT FUNCTION

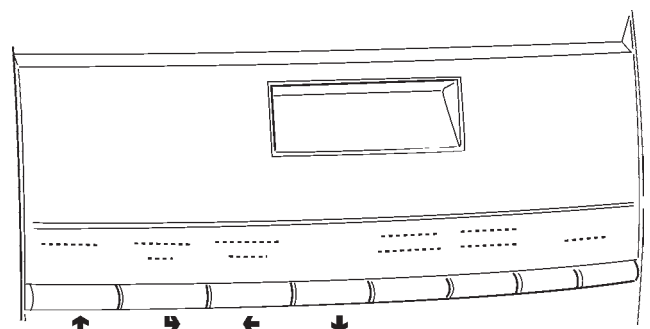

"Technician Menu" Summary

2.2 - SELECTIONS

2.2.1 - SET WATER

2.2.1.1 - WATER DOSES

2.2.1.2 - SET WHIP DOSES

2.2.1.2.1 - SET WHIP DOSES

2.2.1.2.2 - SET MODALITY

2.2.1.3 - EL.VALVE SETTING

2.2.2 - SET POWDER

2.2.2.1 - POWDER DOSES

2.2.2.2 - DOSER SETTING

2.2.3 - SET ACCESSORIES

2.2.4 - SELECTION STATUS

2.2.5 - SEL. <-> BUTTON

2.2.6 - CHECK NO. SELEC.

2.3 - MACHINE PARAM.

2.3.1 - BOILER TEMPERAT.

2.3.2 - TANK

2.3.3 - ENAB.FLUSHBUTTON

2.3.4 - MIXER HEATING

2.3.5 - FAST CYCLES

2.3.6 - MAINT.DISP.SETT

2.3.7 - ENAB.AUTOM.FLUSH

2.3.8 - ENERGY SAVING

2.3.8.1 - SET ENERGY SAV.

2.3.8.2 - ENERGY SAV. PAR.

2.3.9 - PHOTOCCELL

2.3.a - DEC. CYCLE

2.3.b - EQ. CABINET

2.4 - DISPLAY

2.4.1 - LANGUAGE

2.4.2 - PROMO. ADVERT.

2.4.2.1 - ENABLE PR. ADV.

2.4.2.2 - SET PROMO. ADV.



NEXT FUNCTION/
INCREASE DATA UNIT (+1)



PREVIOUS FUNCTION/
DECREASE DATA UNIT (-1)



CONFIRM DATA/
CONFIRM FUNCTION



DELETE DATA/
EXIT FUNCTION

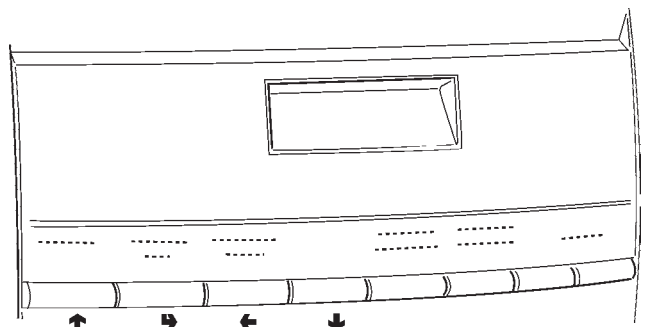

"Technician Menu" Summary

2.5 - PRE-SELECTIONS

2.5.1 - NO CUP

2.5.2 - EXTRA SUGAR

2.5.3 - SUGAR

2.5.4 - SUGAR -

2.5.5 - SUGAR +

2.5.6 - WATER +

2.5.6.1 - SELECTION ENABL.

2.5.6.2 - DOSE VARIATION

2.5.6.3 - PRICE VARIATION

2.5.7 - WATER -

2.5.7.1 - SELECTION ENABL.

2.5.7.2 - DOSE VARIATION

2.5.7.3 - PRICE VARIATION

2.5.8 - STRONG

2.5.8.1 - SELECTION ENABL.

2.5.8.2 - DOSE VARIATION

2.5.8.3 - PRICE VARIATION

2.5.9 - MILD

2.5.9.1 - SELECTION ENABL.

2.5.9.2 - DOSE VARIATION

2.5.9.3 - PRICE VARIATION

2.5.A - POWDER COFFEE

2.5.A.1 - SELECTION ENABL.

2.5.A.2 - DOSE VARIATION

2.5.A.3 - PRICE VARIATION

2.5.B - EXTRA MILK

2.5.B.1 - SELECTION ENABL.

2.5.B.2 - DOSE VARIATION

2.5.B.3 - PRICE VARIATION

2.5.C - MOCHA

2.5.C.1 - SELECTION ENABL.

2.5.C.2 - DOSE VARIATION

2.5.C.3 - PRICE VARIATION

- | | | | |
|---|---|---|---|
| ↓ | NEXT FUNCTION/
INCREASE DATA UNIT (+1) | ↑ | PREVIOUS FUNCTION/
DECREASE DATA UNIT (-1) |
| ↵ | CONFIRM DATA /
CONFIRM FUNCTION | ↵ | DELETE DATA /
EXIT FUNCTION |

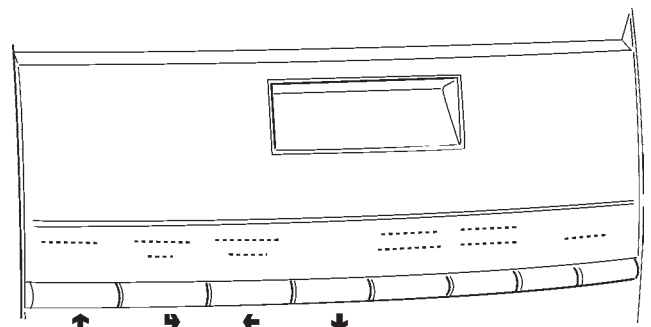

"Technician Menu" Summary

2.5.D - SUGAR +/-

2.5.D.1 - SELECTION ENABL.

2.5.D.2 - DOSE VARIATION

2.5.D.3 - PRICE VARIATION

2.6 - MISCELLANEOUS

2.6.1 - FB DATA

2.6.2 - JUG FACILITIES

2.6.3 - PASSWORD

2.6.3.1 - SET PASSWORD

2.6.3.2 - ENABLE PASSWORD

2.6.4 - ENABLE FILL MENU

3 - STATISTICS

3.1 - ELECTR. COUNTER

3.1.1 - DISPLAY COUNTERS

3.1.2 - RESET COUNTER

3.2 - STATIST. DISPLAY

3.2.1 - SEL. CNT. DISP.

3.2.1.1 - CNT DIS. X S.SEL

3.2.1.2 - TOT CNT DISPLAY

3.2.1.3 - SEL.NO.CNT. DIS.

3.2.2 - DISPLAY BAND CNT

3.2.3 - DISC. CNT. DISP.

3.2.4 - FAIL. CNT. DISP.

3.2.5 - COIN MECH. DISP.

3.2.5.1 - AUDIT DATA DISP.

3.2.5.2 - CASH COUNT. DIS.



NEXT FUNCTION/
INCREASE DATA UNIT (+1)



PREVIOUS FUNCTION/
DECREASE DATA UNIT (-1)



CONFIRM DATA /
CONFIRM FUNCTION



DELETE DATA /
EXIT FUNCTION

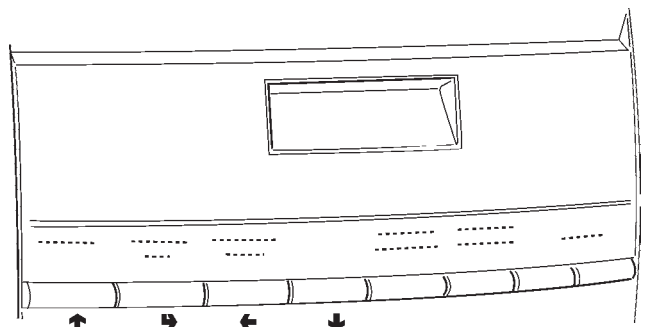

"Technician Menu" Summary

3.3 - STATISTICS RESET

3.3.1 - PARTIAL RESET

3.3.1.1 - SEL. CNT. RESET

3.3.1.2 - DISC. CNT. RESET

3.3.1.3 - FAIL. CNT. RESET

3.3.1.4 - COIN MECH. RESET

3.3.2 - TOTAL RESET

3.4 - DISP. REL. STAT.

3.4.1 - SEL. CNT. DISP.

3.4.1.1 - CNT DIS. X S.SEL

3.4.1.2 - TOT CNT DISPLAY

3.4.1.3 - SEL.NO.CNT. DIS.

3.4.2 - DISPLAY BAND CNT

3.4.3 - DISC. CNT. DISP.

3.4.4 - FAIL. CNT. DISP.

3.4.5 - COIN MECH. DISP.

3.4.5.1 - AUDIT DATA DISP.

3.4.5.2 - CASH COUNT. DIS.

3.5 - DELETE REL.STAT.

3.5.1 - PARTIAL RESET

3.5.1.1 - SEL. CNT. RESET

3.5.1.2 - DISC. CNT. RESET

3.5.1.3 - FAIL. CNT. RESET

3.5.1.4 - COIN MECH. RESET

3.5.2 - TOTAL RESET

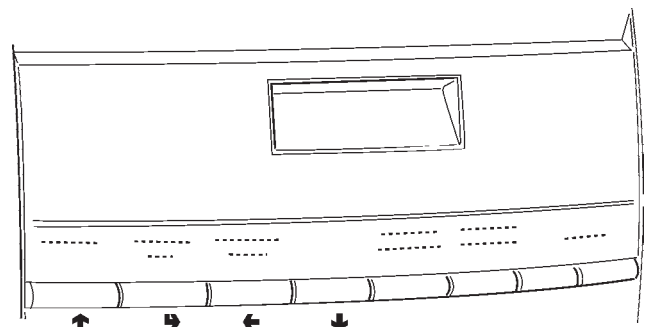

"Technician Menu" Summary

3.6 - EN. CNT AT START

3.7 - STATIS. PRINTING

3.7.1 - PARTIAL PRINTING

3.7.1.1 - SEL. CNT. PRINT.

3.7.1.2 - PRINT BAND CNT

3.7.1.3 - DISC. CNT.PRINT.

3.7.1.4 - FAIL. CNT.PRINT.

3.7.1.5 - COIN MECH. PRINT

3.7.2 - TOTAL PRINTING

3.8 - PRINT REL. STAT.

3.8.1 - PARTIAL PRINTING

3.8.1.1 - SEL. CNT. PRINT.

3.8.1.2 - PRINT BAND CNT

3.8.1.3 - DISC. CNT.PRINT.

3.8.1.4 - FAIL. CNT.PRINT.

3.8.1.5 - COIN MECH. PRINT

3.8.2 - TOTAL PRINTING



NEXT FUNCTION/
INCREASE DATA UNIT (+1)



PREVIOUS FUNCTION/
DECREASE DATA UNIT (-1)



CONFIRM DATA /
CONFIRM FUNCTION



DELETE DATA /
EXIT FUNCTION

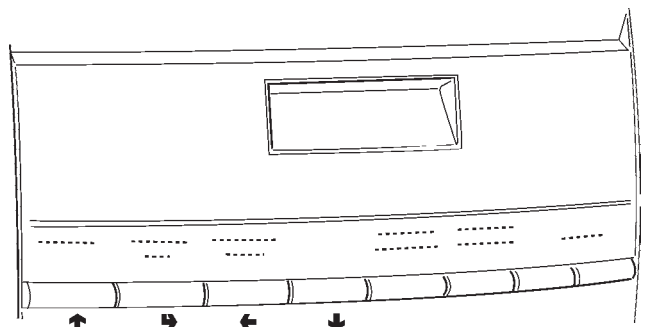

"Technician Menu" Summary

4 - TEST

4.1 - TEST DISPENSING

- 4.1.1 - COMP. DISPENSING
- 4.1.2 - WATER ONLY
- 4.1.3 - POWDER ONLY
- 4.1.4 - WITHOUT ACCESS.
- 4.1.5 - ACCESSORIES ONLY

4.2 - SPECIAL FUNCT.

- 4.2.1 - ESPR.UNIT ROTAT.
- 4.2.2 - RELEASE DOSE
- 4.2.3 - EMPTY ES. BOILER
- 4.2.4 - MANUAL INSTALL.
- 4.2.5 - FRESH BREW UNIT

4.3 - AUTOTEST

5 - MISCELLANEOUS

5.1 - D.A. REGISTRY

- 5.1.1 - INSTALL. DATE
- 5.1.2 - PROG. M/C CODE
- 5.1.3 - OPER. CODE ENTRY

5.2 - INITIALISING DB

5.3 - ADD HOT WATER

- | | | | |
|---|---|---|---|
| ↓ | NEXT FUNCTION/
INCREASE DATA UNIT (+1) | ↑ | PREVIOUS FUNCTION/
DECREASE DATA UNIT (-1) |
| ↵ | CONFIRM DATA /
CONFIRM FUNCTION | ↶ | DELETE DATA /
EXIT FUNCTION |

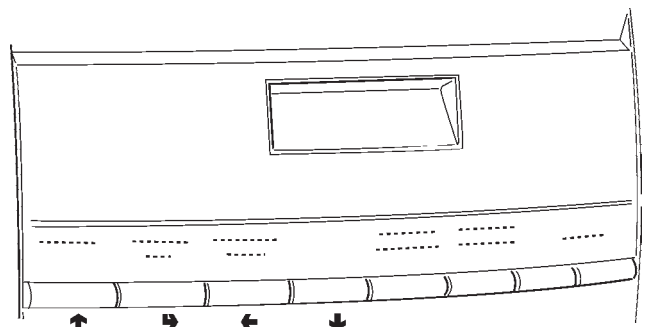

WIRING DIAGRAM LEGEND

INITIALS	DESCRIPTION	INITIALS	DESCRIPTION
CCG	GENERAL COUNTER	M	COFFEE UNIT MOTOR
CM1	COFFEE UNIT MOTOR CAM	MAC	GRINDER
CV	VOLUMETRIC COUNTER	MD1-..	INGREDIENT MOTOR - INSTANT
EEA	WATER INLET SOLENOID VALVE	MDFB	INGREDIENT MOTOR - FRESH BREW
ER	COFFEE DISPENSER SOLENOID VALVE	MF1-..	WHIPPER MOTORS
ESP1-.	DRAINING SOLENOID VALVE	MFB	FRESH-BREW MOTOR
EV1-..	INSTANT SOLENOID VALVES	MPF	PRESH BREW PISTON MOTOR
EVDEV	FLOW DIVERTER SOLENOID VALVE	NTC	TEMPERATURE PROBE
EVFB	FRESH BREW SOLENOID VALVE	PM	PUMP
FA	RADIO INTERFERENCE SUPPRESSOR	RCC	COFFEE BOILER HEATING ELEMENT
ID	COFFEE DOSE SWITCH	RCS	INSTANT BOILER HEATING ELEMENT
IDEC	DECAFFEINATED DOOR SWITCH	RG	UNIT HEATING ELEMENT
IG	MAIN SWITCH	SM	CONTROL BOARD
IP	DOOR SWITCH	SM1	CONTROL BOARD
IPC	FULL CAPSULES CONTAINER SWITCH	SMFB	FRESH BREW CONTROL BOARD
IPF	WASTE CONTAINER OVERFLOW SWITCH	STRC	BOILER HEATING TRIAC BOARD
IPV1-.	DISPENSING COMPARTMENT SWITCH	TR	TRANSFORMER
IVA	EMPTY BOILER MICRO-SWITCH	TX....	DELAYED FUSE (X=COURRENT)
KC1-..	COFFEE BOILER CUTOUT	UPS	COLD UNIT PRINTED BOARD
KS1-..	SAFETY CUTOUT	VENT	FAN
LCD	LIQUID CRYSTAL DISPLAY		

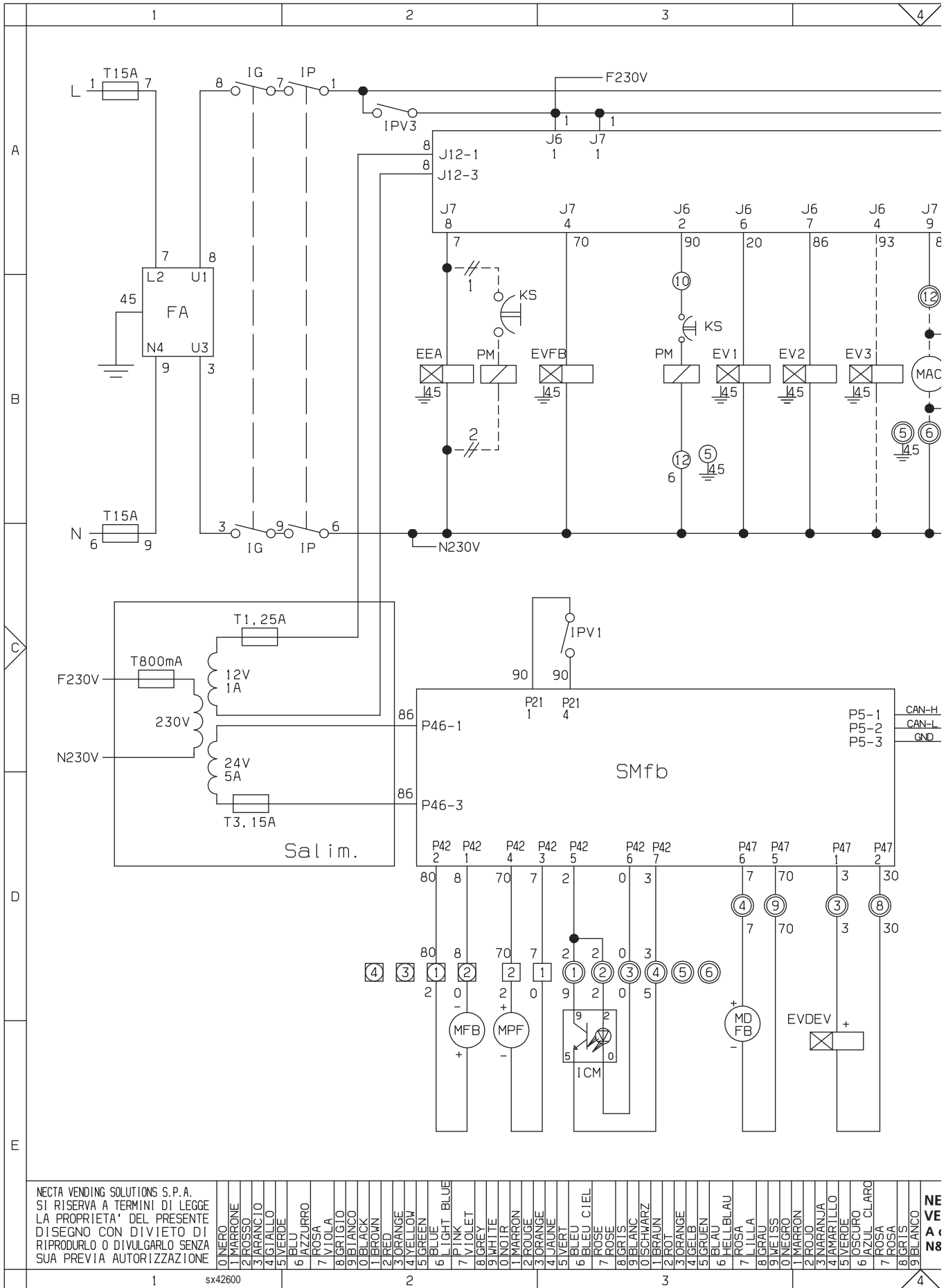

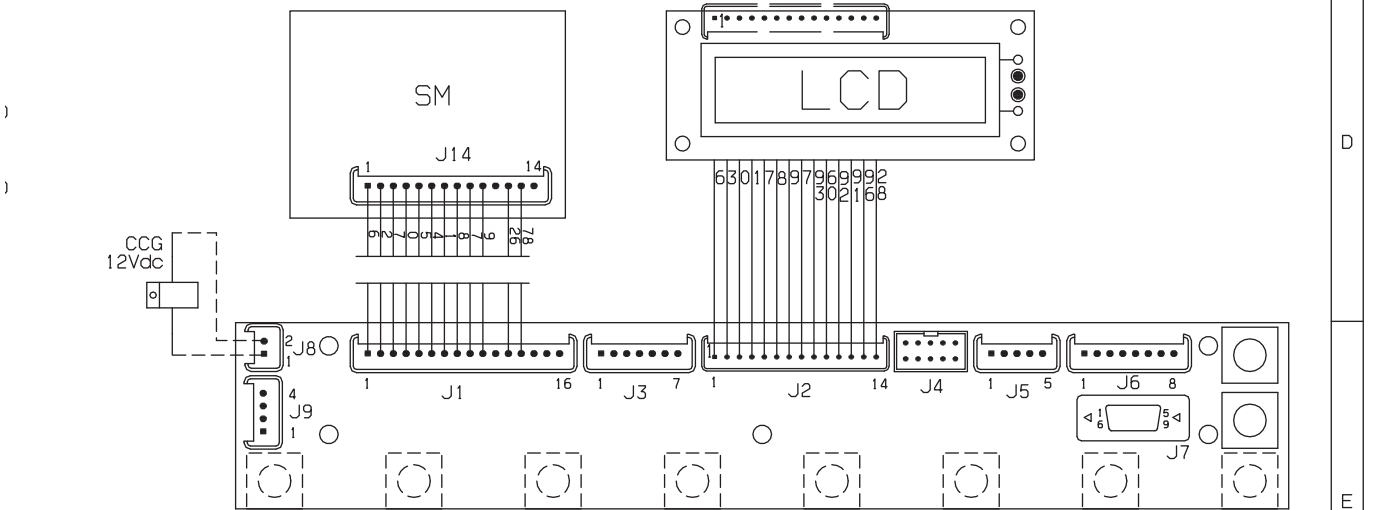
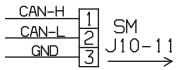
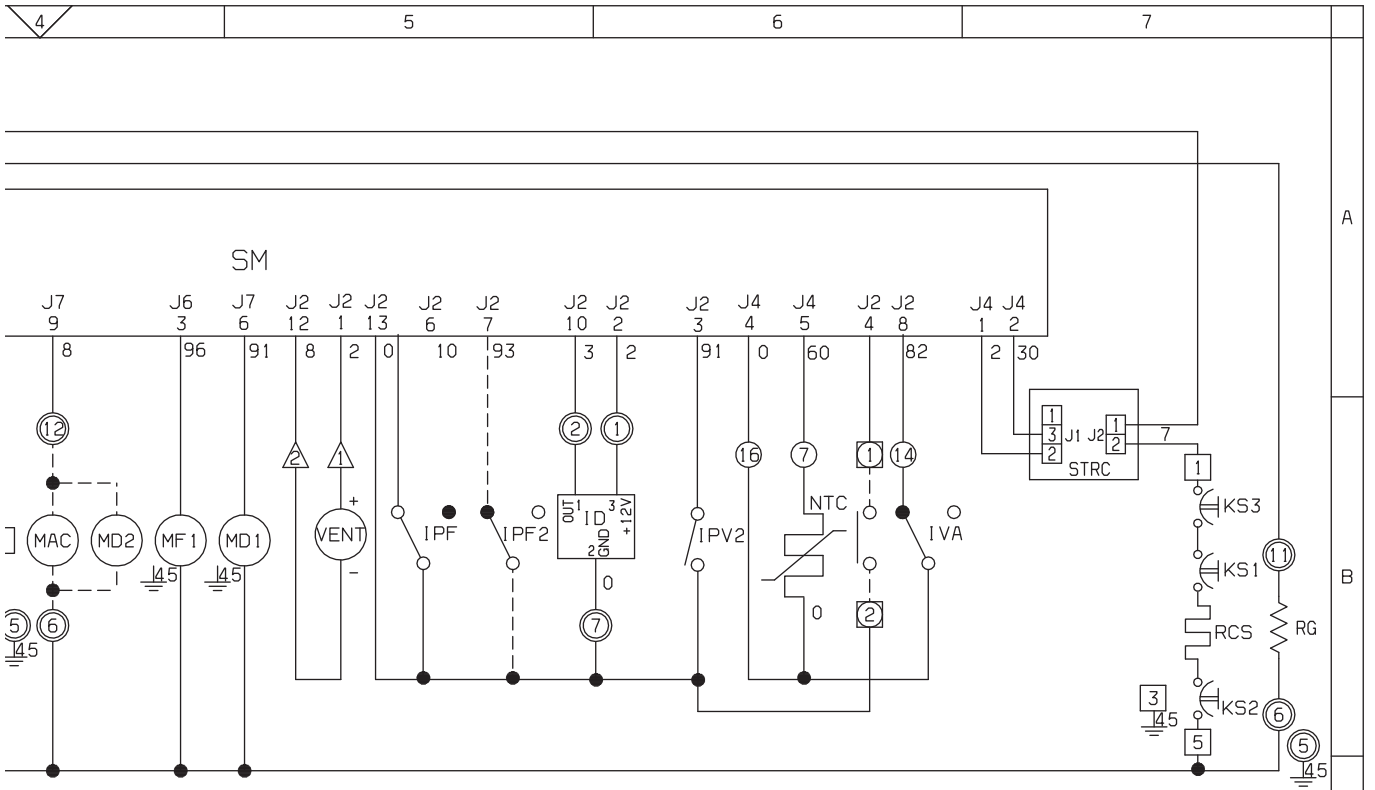

8 GRIS 9 BLANCO	NECTA VENDING SOLUTIONS SpA A company of N&W GLOBAL VENDING GROUP	MODELLO Koro Fresh Brew	GRUPPO SCHEMA ELETTRICO FUNZIONALE OCS SIGMA-BREWER	DATA 10-06-03	FOGLIO 1 / 1	DISIGNATO BONACINA	CONTROLLATO MONGUZZI
					LEGENDA	CODICE 608542600	



The Manufacturer reserves the right to modify, without prior notice, the characteristics of the equipment described in this publication; and further declines to accept any responsibility for any inaccuracies contained in this publication which can be ascribed to printing and/or transcription errors.

All instructions, drawings, tables and information contained in this publication are confidential and can neither be reproduced completely or in part, nor be transmitted to third parties without the written permit of the Manufacturer, who has the sole ownership.

EDITION 1 04 - 2005 CODE: H 253U 00

