

Technical manual Nova Instant





Technical manual Nova Instant

Manufacturer: ETNA Coffee Technologies b.v.
P.O. Box 200
7130 AE Lichtenvoorde
The Netherlands

Distributor:

© ETNA Coffee Technologies b.v.

Articlecode: 000868660001
Status: Publish
Revision: 1

CONTENTS

1	INTRODUCTION	6
1.1	This user manual	6
1.2	Pictograms and safety symbols on the machine	6
1.3	Pictograms and safety symbols in the manual	7
1.4	Conventions and definitions	7
1.5	Service and technical support.	7
1.6	Machine identification on the exterior of the machine	8
1.7	Machine identification inside the machine.	8
1.8	Used machines and the environment.	9
1.9	General safety instructions and restrictions	9
1.9.1	Operating and cleaning instructions	9
1.9.2	Icons and instructions	9
1.9.3	Users	10
1.9.4	Technical specifications	10
1.9.5	Modifications	10
1.9.6	Intended use	10
1.10	Available documentation	10
2	DESCRIPTION OF MACHINE	11
2.1	General description	11
2.2	Main components	11
2.2.1	Front view	11
2.2.2	Interior view	12
2.3	Container lay-out	13
2.4	Principle of operation.	13
2.5	Switching ON and OFF.	13
2.6	Service key	14
2.7	Operating the machine.	14
2.7.1	Strength control	14
2.7.2	Selecting jug function	15
2.7.3	Stand by	15
3	USE	16
3.1	Safety instructions - use	16
3.2	Refilling containers	17
3.2.1	Filling the container inside the machine	17
3.2.2	Filling the ingredient containers outside the machine	17
3.3	Digital photo frame.	18

4	MAINTENANCE AND CLEANING	19
4.1	Safety instructions - maintenance and cleaning	19
4.2	Perishables	19
4.3	Service panel	20
4.4	Maintenance	20
4.5	Daily maintenance	21
4.5.1	Checking the ingredient containers	21
4.5.2	Cleaning drip tray	21
4.5.3	Cleaning the mixers	22
4.5.4	Cleaning valves	22
4.5.5	Clean the exterior	22
4.6	Weekly maintenance	23
4.6.1	Cleaning mixer components	23
4.7	Maintenance overview	24
5	RESOLVING PROBLEMS	26
5.1	LCD display on the selection panel	26
5.1.1	Fault messages	26
5.1.2	Selection panel in programming mode	27
5.1.3	User menu (Operator)	27
5.1.4	Diagram of user menu	28
5.2	Service engineer menu	28
5.3	Electrical diagram	29
5.4	Water flow diagram	30
6	TECHNICAL SPECIFICATIONS	31
6.1	Electrical system	31
6.2	Water system	31
6.3	Sound level	31
6.4	Ambient conditions	32
6.5	Dimensions and weight	32
7	SOFTWARE	33
7.1	Software versions	33
7.2	Levels	33
7.3	User menu (Operator)	33
7.4	Service engineer menu	34
7.5	Drink settings	35
7.5.1	Setting drink recipes	37
7.6	Drink counters	38
7.7	Machine counters	39
7.8	Cleaning counters	39
7.9	Time & date	40
7.10	Timer functions	41
7.11	Temperature	42
7.12	Error settings	43
7.13	Installation	44
7.14	Payment system	46
7.15	Pin code	47
7.16	Calibrate the valves	48
8	INSTALLATION	49
8.1	Connecting the machine	49
8.2	Adjusting the valve	49
8.3	Test the buttons	50

9	REPLACEMENT OF PARTS	51
9.1	Safety requirements - replacing parts	51
9.2	Repairs	51
9.2.1	Access to the machine	51
9.2.2	Removing the plating	52
9.3	Emptying the boiler	53
9.4	Restarting	53
9.5	Drink selection labels	54
9.6	Replacing the inlet valve	54
9.7	Replacing the boiler	55
9.8	Replacing the boiler sensor	57
9.9	Replacing the heating element	58
9.10	Replacing the valve	59
9.11	Replacing the extraction fan	60
9.12	Replacing the mixer engine	61
9.13	Replacing the ingredient engine	61
9.14	Replacing the espresso mixer	62
9.15	Replacing the drip tray sensor	63
9.16	Door plate	63
9.17	Replacing the cup sensor	64
9.18	LCD display and display PCB	65
9.19	Replacing the selection panel print	66
9.20	Replacing the illumination panel	67
9.21	Digital photo frame (optional)	68
9.22	Replacing the control PCB	71
9.23	Replacing the level sensor PCB	71
9.24	Replacing the power supply	72

1 INTRODUCTION

1.1 This user manual

Congratulations on the purchase of yourNova Instant. This machine has been developed and produced using state-of-the-art technology. This, combined with the ISO 9001 certification that applies to all our products, means you can rest assured that you are the owner of a high quality product.

This manual is intended for authorised and trained users and contains all the information required to operate the machine safely and to carry out regular maintenance and cleaning tasks. Read the relevant user manual carefully before using your machine.



Ensure that the user manual is kept with the machine to ensure that all procedures are carried out correctly.



Figure 1-1

1.2 Pictograms and safety symbols on the machine

The following pictograms are used on the Nova Instant:

- Electrical hazard
- Risk of fingers being trapped



Figure 1-2



Figure 1-3

1.3 Pictograms and safety symbols in the manual

These pictograms are used in the manual:



General warning or caution. Damage to the machine or personal injury can occur.



Electrical hazard



Burning hazard



Remarks, suggestions and advice

1.4 Conventions and definitions

Throughout the document, reference is made to the "left", "right", "front" and "rear" of the machine. Where a component or specific part of the machine is referred to, this is described from the user's viewpoint facing the selection panel.

1.5 Service and technical support

Please contact your dealer for further information on settings, maintenance and/or repair activities that are not dealt with in this manual. Your dealer will be pleased to assist you.

If you contact your dealer, always have the following information at hand:

- model number
- serial number
- software versions

1.6 Machine identification on the exterior of the machine

1. Model number
2. Voltage
3. Frequency
4. Power rating
5. Serial number
6. Water pressure

The identification plate is on the rear of the machine.

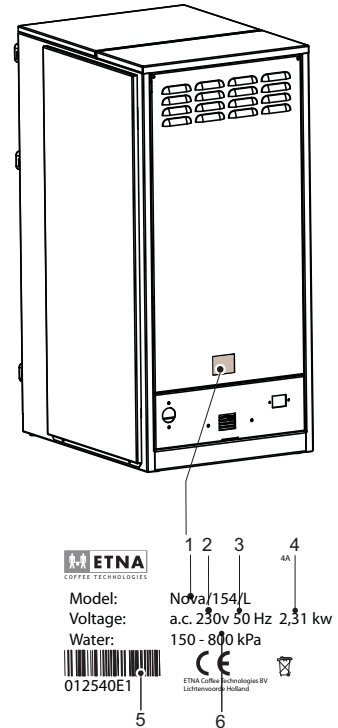

Figure 1-4

1.7 Machine identification inside the machine

1. Model number
2. Voltage
3. Frequency
4. Power rating
5. Serial number
6. Water pressure

The identification plate is on the inside on the left-hand frame plate.

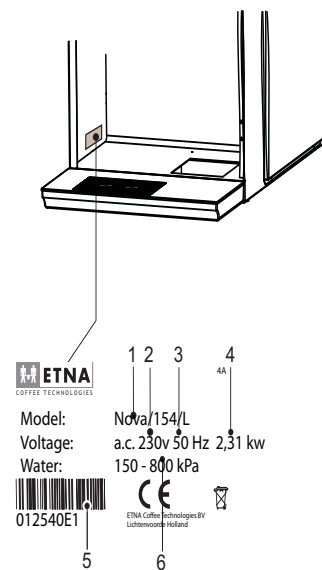
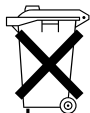

Figure 1-5

1.8 Used machines and the environment



Ask your local authority for information on ways to recycle materials safely and in an environmentally friendly manner.



Ask your local authority for information on ways to dispose of materials safely and in an environmentally friendly manner.

1.9 General safety instructions and restrictions

The manufacturer does not accept liability for any damage caused by not (strictly) observing the safety instructions or by carelessness during use and cleaning of the machine and any accessories.

Depending on the specific operating conditions or accessories used, additional safety instructions may apply. Please contact your dealer immediately if you encounter any hazards when using the machine.



The user of the machine is fully responsible at all times for observing locally applicable safety regulations and guidelines.

1.9.1 Operating and cleaning instructions

- All those using and/or cleaning the machine must be familiar with and follow the operating and cleaning instructions closely. The owner must ensure that personnel are informed of the operating and cleaning instructions contained in this manual and that they comply with these regulations and instructions.
- Never change the order in which activities are carried out.
- Always keep the operating and cleaning instructions in the vicinity of the machine.

1.9.2 Icons and instructions

The icons, symbols and instructions attached to the machine form part of the safety instructions. Therefore, they must not be covered or removed. They must be kept within reach and be clearly legible throughout the entire service life of the machine.

- If icons, symbols or instructions are illegible, ring your supplier straightaway to rectify this.

1.9.3 Users

The daily, weekly and monthly maintenance and cleaning activities may only be carried out by users who have received training from the installer or owner of the machine. These individuals will be familiar with the potential risks of opening the machine. Staff who are still in training must be supervised when carrying out cleaning activities. This must be under the responsibility of an authorised user.

1.9.4 Technical specifications

- The technical specifications may not be modified.

1.9.5 Modifications

- Modifications may not be made to the machine (or parts of the machine).

1.9.6 Intended use

The intended use¹ of the machine is designed exclusively for dispensing beverages as indicated on the selection panel. Use of the machine for any other purpose falls outside the terms of conditions of use. The manufacturer does not accept responsibility for any damage or injury that may result from improper use.

The machine meets current standards and directives.

- The machine may only be used in perfect technical condition for the purposes indicated above.

1.10 Available documentation

The following documentation is available for this machine:

- User manual
- Technical manual
- Parts book

1. "Intended use" as meant in EN 292-1 is the application for which this technical product has been made, as specified by the manufacturer – including references in sales brochures. In case of doubt, use can be derived from the construction, model and functions of the technical product the assumed normal use. Use of the product within the confines of the intended use also includes complying with the instructions in the user manual.

2 DESCRIPTION OF MACHINE

2.1 General description

This machine prepares and dispenses various hot drinks.

The drinks are dispensed in the cups intended for this purpose and that are placed on the machine cup stand. The cups must be placed on the cup stand manually.

The display on the machine indicates that:

- a drink can be selected
- a drink is being prepared
- a fault has occurred.

2.2 Main components

2.2.1 Front view

1. Window (optional: photo frame)
2. Display
3. Selection panel
4. Cup sensor
5. Cup stand (two-sided)
6. Drip tray

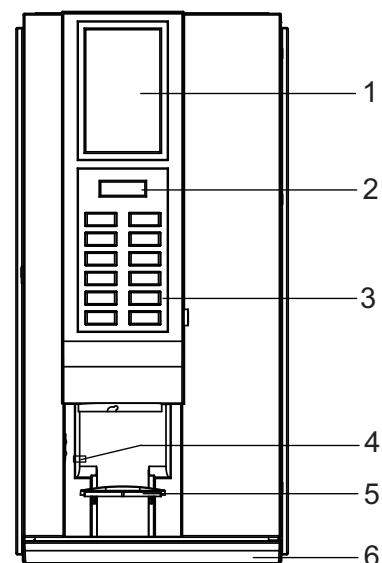

Figure 2-1

2.2.2 Interior view

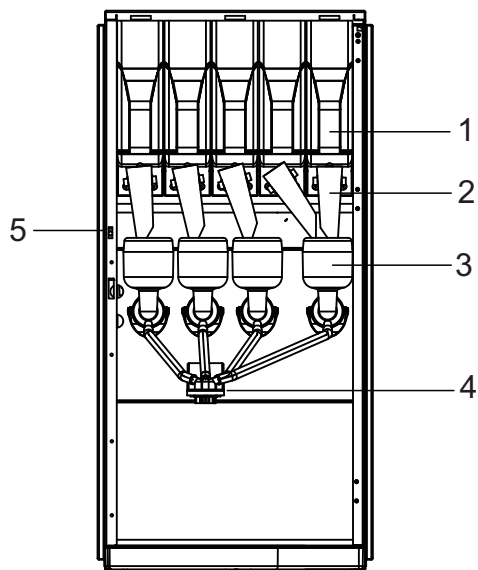

Figure 2-2

1. Ingredient containers
2. Dispenser nozzle
3. Mixer components
4. Dispensing holder
5. Service switch

2.3 Container lay-out

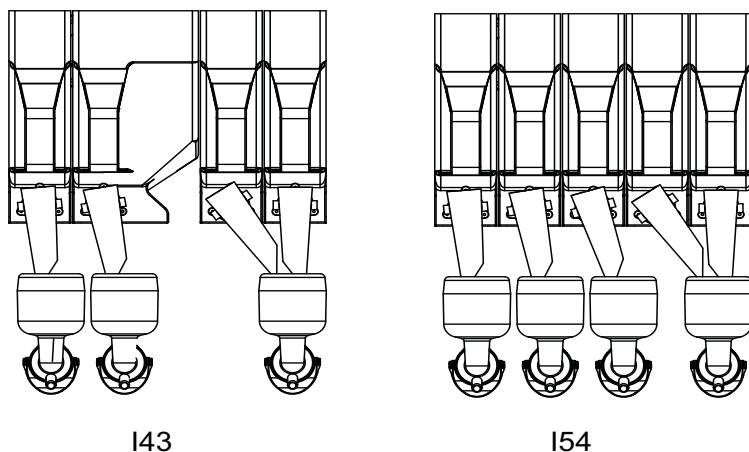

Figure 2-3

The different types are fitted with the following containers.

Machine	Instant container
Nova I43	3x 2.3 L 1x 4.8 L
Nova I54	5x 2.3 L

2.4 Principle of operation

After a selection is made, the drink is prepared and dispensed.

- The water is supplied via the boiler (heated).
- Instant products are dosed from the containers into the mixer and/or the ground coffee is dosed into the brewing group.
- The water and the ingredients are mixed in the mixer or compressed by the brewing group.
- The drink is dispensed through the dispensing pipe into the cup placed on the cup stand.
- The cup stand has two sides; hot water on the left, drinks on the right.
- The start button can be used when a drink has been selected and a cup has been placed.

2.5 Switching ON and OFF

The machine does not have a manual on/off switch. The key switch used to open the door incorporates the on/off switch:

- When the door is opened the machine switches itself off.
- When the door is closed the machine switches itself back on.

2.6 Service key

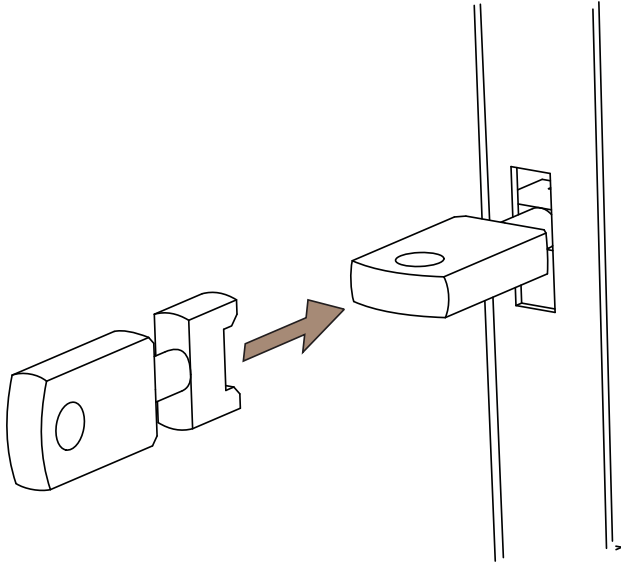

Figure 2-4

Once the service key has been inserted and turned a quarter turn, the machine is operational for repair and test purposes.



The machine contains rotating and moving parts. Ensure that your fingers do not become trapped when work is carried out.

2.7 Operating the machine

Although the standard model does not include a payment mechanism, the option exists for the machine to be equipped with a coin mechanism (for instructions on how to install the payment mechanism, see the operating instructions included with the mechanism).

2.7.1 Strength control

Select the drink by pressing the button.

The strength can be changed by pressing the selected drink again.

This is also an option when adding items such as sugar and milk, if the machine allows for this.

2.7.2 Selecting jug function



If the jug function is switched on the cup sensor is switched off.

The jug function allows you to select more than one cup at once. This button operates with all available drinks. The procedure for selecting more than one cup is described below.

1. Push the cup stand up and put a jug under the dispensing nozzle.
2. Use the **jug function** button and press the desired selection button several times.
3. Now operate the **MILK** and/or **SUGAR** buttons to obtain the required combination.
4. Press the **START** selection button for the required drink. The jug is filled. Ensure that the jug is large enough for the number of cups selected.

To reduce the number of cups while the machine is dispensing, press the **jug function** button several times until the required number appears. The machine will stop after the current cup is dispensed.

If the machine is equipped with a coin mechanism and key switch for the jug function, the free dispensing mode is activated by inserting the key in the lock (switch) and turning it to the right.

2.7.3 Stand by

Stand by mode is indicated by the following:

- The buttons are not illuminated.
- The illumination panel or photo frame (optional) is on.
- The Shift button flashes green.

Press any button to bring the machine out of stand by.

3 USE

3.1 Safety instructions - use

- Inspect the machine before use and check for any damage and defects.
Please contact your supplier if there is any damage to the machine.
- Please keep all packaging out of reach of children.
- Place the machine in a horizontal position.
- Place the machine somewhere where it can be supervised by trained personnel.
- The machine is not intended for use by people (including children) with a physical, mental or sensory handicap, or with insufficient knowledge and experience to use it without supervision or instruction, until they are monitored by someone who is responsible for their safety.
- Children must be supervised to ensure that they do not play with the machine.
- Protect the machine from water and/or moisture.
- Do not clean the machine using a high pressure water jet.
- Keep the buttons free from dirt and grease, clean them regularly.
- Only use the machine if the lids on the top are closed and all plating has been fitted.
- Never use sharp objects to operate the buttons.
- Only use the cups or jugs that are available at the counter.
- Ensure that the wall socket (with earth connection) and the water connection point remain accessible during use. In case of emergency, the mains plug can then be removed quickly and the water supply can be shut off immediately.
- If the machine is not going to be used for some time, remove the containers, clean the hoses, clean the machine manually, thoroughly clean the mixing chamber, empty the boiler, shut off the water supply and remove the plug from the wall socket. There must not be any water in the machine and components.
- To use the machine after a long period of non-use, first clean the mixing chamber and brewing group thoroughly. Replace the mixing chamber and run the cleaning programme at least three times and prime all the containers before operating the machine.



The drink dispensed by the machine is very hot. You may cause burns in the event of spillage.



Remove the plug from the wall socket in the event of any danger. Do not pull the plug from the wall socket using the cable.



Disregarding the above instructions can jeopardise the safe use of the machine.

3.2 Refilling containers

The containers hold the ingredients required to prepare drinks. The containers can be refilled as follows (2 methods):

- Open the upper lid and fill the container inside the machine
- Remove the container from the machine and fill.

3.2.1 Filling the container inside the machine

1. Open the door of the machine.
2. Open the lid on the container that needs refilling. Refill the container with the correct ingredients.
3. Close the upper lid.
4. If the container was completely empty, the supply will need refilling.
 - Hold the container above the waste bucket. Turn the spindle of the container until the ingredient runs out of it.

3.2.2 Filling the ingredient containers outside the machine

The containers hold the ingredients required to prepare drinks.



Ensure that no fingers are trapped when filling the containers.



Make sure that the right ingredient is put in the correct container.



See the label on the inside of the door for an overview of the maintenance functions.

1. Open the door of the machine.
2. Open the upper lid.
3. Lift the container to be filled off the holder and pull it towards you.
4. Fill with the desired ingredient.
5. Replace the container in the same place in the machine. Ensure that the container's coupling falls into the gear.
6. Repeat this procedure for the other ingredient containers.
7. Close the upper lid.
8. Place a 0.5 L cup under the dispensing nozzle.
9. Insert the service key and turn it a quarter turn.
10. Press button 0 on the service panel; clean valves, the valves are rinsed with water. Repeat this if necessary.
11. Press button 7 on the service panel; reset ingredient counters.
12. Turn the service key a quarter turn and remove it.
13. Close the machine door.

3.3 Digital photo frame



Please refer to the manuals enclosed for the correct use of the remote control and the digital photo frame.

The USB connection can be seen on the inside of the door on the door plate when the door is opened.

Operating the photo frame



The photo display is operated with the remote control.

The photos can be stored on a memory card (SD, MS, MMC, XD). The photos must be in JPG format.

- 1 Select Photo in the main menu and press Enter or OK.

The photo browser is shown.

- 2 Select the directory with the photos that are to be shown.
- 3 Press Enter or OK.
- 4 The photos are shown automatically.

Changing photos

- 1 Select Edit in the main menu and press Enter or OK.

- 2 The Edit menu is shown.

Select from Copy, Delete or Edit

- 3 Press the arrow to scroll through the menu.

Press Enter or OK to confirm your selection.

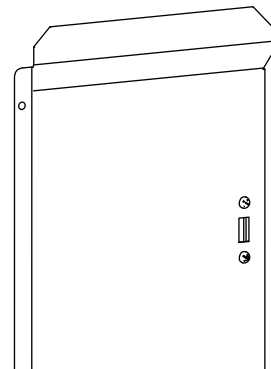

Figure 3-1

4 MAINTENANCE AND CLEANING

Accurate maintenance and in particular careful cleaning are basic conditions for good product quality and smooth operation.

This machine has been developed to enable the owner or licensee to thoroughly clean and maintain it in a relatively short time and at low cost.



First read par. 4.1 before carrying out any maintenance activities on the machine. The maintenance activities described may only be carried out by trained, authorised users under the supervision of trained personnel or the owner.

4.1 Safety instructions - maintenance and cleaning

- See also par. 3.1.
- Carry out the procedures taking into account the hygiene regulations.
- Repairs may only be carried out on the machine by trained service engineers.
- Maintenance work on the electrical system may only be carried out by trained service engineers with a background in electrical engineering.



Warning with respect to burns: parts within the machine can be very hot.

- After cleaning or maintenance activities, the machine must not be used until all the removed parts have been correctly reinstalled.

Then inspect and check the inside of the machine:

- The dispenser holder must be aimed at the middle of the cup.
- The ingredient containers must be correctly placed.
- The mixer components must be in the correct position.
The waste container must be in the correct position.
- The brewer group must be in the correct position.

4.2 Perishables



The products have been supplied with a use by date. Therefore, the following should be taken into account:

- Comply with the use by date printed on the product packaging.
- Do not use products that are nearing their use by date.
- Replace products whose use by date is past.
- Do not use opened products for longer than the indicated use by date.
- Replace the products when the use by date is up.
- Only use the cleaning agents referred to in the cleaning schedule and follow the instructions on the packaging. See also par. 4.4.

4.3 Service panel

The service panel can be seen when the door is opened. From the service panel you can carry out the following maintenance tasks (if available):

Button	Function
1	Rinse brewing group
2	Rinse mixer 1
3	Rinse mixer 2
4	Rinse mixer 3
5	Open/close brewing group
6	Free/paid drink
7	Reset container counters
8	Read counters
9	Reset waste counter
0	Cleaning valves

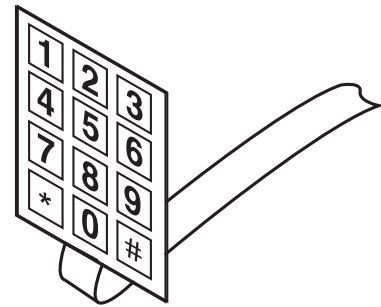

Figure 4-1

4.4 Maintenance

The quality of this product is only guaranteed if the machine receives thorough maintenance on a regular basis. A few vital machine parts are very sensitive to dirt. Use of this machine requires both daily and weekly maintenance.

4.5 Daily maintenance

Carry out the following operations on a daily basis:

- Check the contents of the ingredient containers and refill them if necessary.
- Clean and empty the drip tray.
- Rinse the mixers, brewer and valves (at least twice a day).
- Clean the outside of the machine, including the selection panel.

When cleaning, pay attention to the following:

- Clean the machine and parts with a damp, clean cloth or paper tissue.
- Always put the cleaned parts straight back in the machine.
- Clean the machine more frequently than specified if necessary; more frequent cleaning will be required when the machine is subject to heavy use.

4.5.1 Checking the ingredient containers

1. Open the door.
2. Check whether the ingredient containers still contain sufficient ingredients.
3. If necessary refill the containers as described in Chapter 3
4. Close the door.

4.5.2 Cleaning drip tray



The drip tray must not be washed in a dishwasher.

1. Take the drip tray out of the machine carefully.
2. Empty the drip tray and clean it using water.
3. Put the drip tray back in the machine.

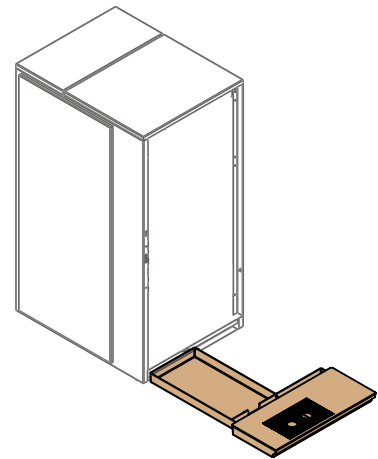

Figure 4-2

4.5.3 Cleaning the mixers



The drink dispensed by the machine is very hot and may cause burns.

1. Open the door and insert the service key.
2. Place a cup or jug of at least 0.5 L under the dispensing nozzle.
3. To rinse the mixers, press button 0; rinse valves.
4. To rinse the mixer(s) several times:
 - Press the jug button (selection panel) to set the number of rinses;
 - Press button 1, 2, 3, 4 or 5 to rinse the relevant mixer(s);
 - The mixer(s) is/are now rinsed the required number of times.
5. Turn the service key a quarter turn and remove it.
6. Close the machine door.



Note: ensure that the jug or container is large enough to collect the rinsing water.

4.5.4 Cleaning valves



The drink dispensed by the machine is very hot and may cause burns.

1. Open the door and insert the service key.
2. Place a cup of at least 1.5 L under the dispensing holder.
3. Press button 0 on the service panel; clean valves.
4. All valves are cleaned.
5. Remove the cup.
6. Turn the service key a quarter turn and remove it.
7. Close the machine door.
8. Empty the cup.

4.5.5 Clean the exterior

Clean the outside of the machine. Pay special attention to:

- The selection panel
- The area around the drink dispenser unit.
- The bottom of the door.

4.6 Weekly maintenance

Carry out the following operations on a weekly basis:

- Clean the mixer components

4.6.1 Cleaning mixer components

Clean the following components during weekly maintenance:

- Extractors
- Mixing bowls
- Hoses
- Extraction lid



Wash your hands before continuing with this procedure.

1. Open the door.
2. Remove the closed ingredient containers from the machine. Keep them in a clean and dry place.
3. Detach the hoses from the mixing chambers.
4. Detach the hoses from the dispensing pipes.
5. Remove the dispensing pipes from the dispensing holder.
6. Release the mixing chamber by pulling the green catch below it forwards.
7. Take the mixing chamber out of the machine by carefully pulling the bottom of the chamber towards you.
8. Remove the extraction lid from the machine.
9. Remove the mixer blade from the axle of the mixer motor. Use the mixing chamber as a hoist to do so.
10. Clean all parts in hot water and dry them carefully.
11. Clean the immediate vicinity of the mixer in the machine with a damp cloth.

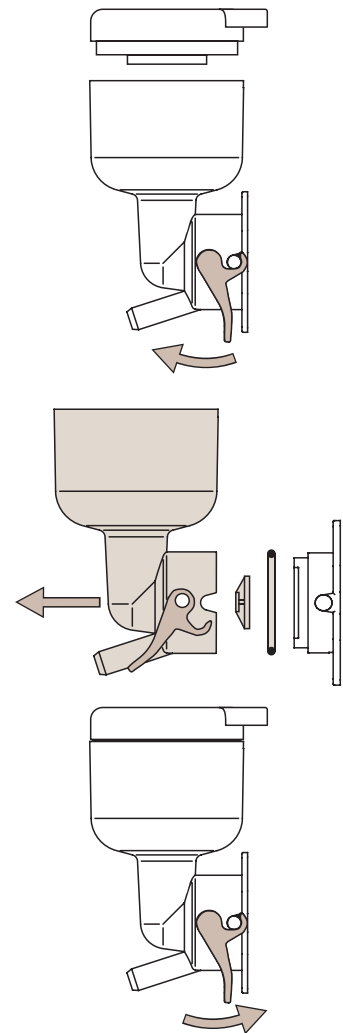

Figure 4-3

12. Put the mixer blade back. Ensure that the marking point on the mixer blade is lined up with the flat section on the engine axle.
13. Put the other cleaned parts back and connect the hoses.

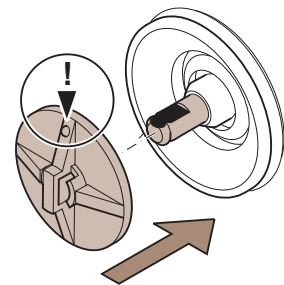

Figure 4-4



The mixing chamber must latch securely in place to prevent leaks. Ensure that the green catch snaps back into place.

14. Insert the service key and turn it a quarter turn.
15. Place a 1.5 L cup under the dispensing nozzle.
16. Press button 0 on the service panel; cleaning valves.
17. Check the system for leaks.
18. Turn the service key a quarter turn and remove it.
19. Close the machine door.

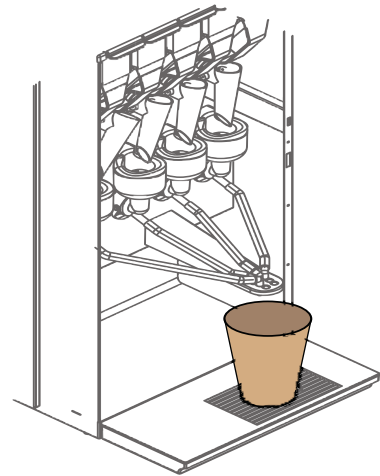

Figure 4-5

4.7 Maintenance overview

The labels with an overview of the maintenance to be carried out have been stuck to the inside of the door.



Figure 4-6

5 RESOLVING PROBLEMS

5.1 LCD display on the selection panel

If faults occur in the machine, the LCD display on the selection panel will display a fault message.

5.1.1 Fault messages

Despite taking all precautionary measures, faults may occur in the machine. In this case, a fault message is displayed. The table below shows a number of faults that could occur and their causes and remedies.

Fault message	Cause	Remedy
Fill container x	Container x is empty	Fill the container and reset the fault message, see Filling containers
Empty waste bucket	The waste bucket is full	Empty waste bucket and clean it, see Emptying waste bucket
Rinse brewing group		Rinse the brewing group, see Cleaning the brewing group automatically
Cleaning the brewing group		Cleaning the brewing group manually, see Cleaning the brewing group
Empty drip tray	The drip tray is full	Empty drip tray, see Cleaning drip tray
Exact change	Not enough change in money changer	Pay with exact change
Drink switched off	Selected drink not available	Contact your supplier
Replace lime scale filter	Filter has exceeded its service life	Replace the filter
Boiler is heating up	Boiler temperature is too low	Wait until the boiler has heated up
No water	Water level too low	Check the machine's water supply

5.1.2 Selection panel in programming mode

When the programming mode is used, the selection panel has the following functions:

- **+ or -**, these buttons are used to navigate the menu, or to increase or decrease values.
- **START**, this button confirms the value that is set.
- **#**, (on the service panel) this button is used to navigate back through the menu.

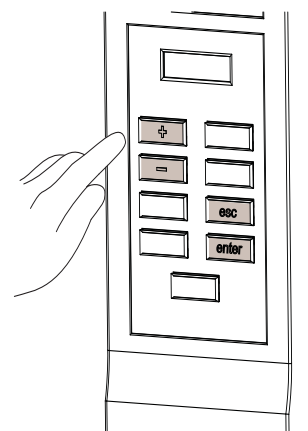

Figure 5-1

5.1.3 User menu (Operator)

Press # on the service panel and enter the PIN code.

The standard PIN code for the user menu is **4321**.

Menu subject	Description
Beverage counters	- reading the counter settings per drink - resetting the counter settings
Time & date	- changing time - changing date - changing day - switching on/off on display - setting time adjustment
Temperature	- changing the temperature (set water default 100°C, coffee water default 90°C, range 80-100°C) - setting the sensor

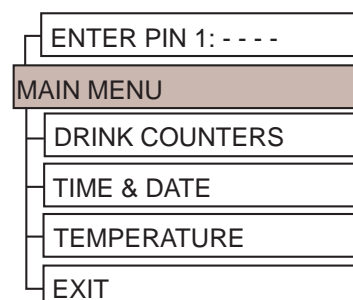

Figure 5-2

5.1.4 Diagram of user menu

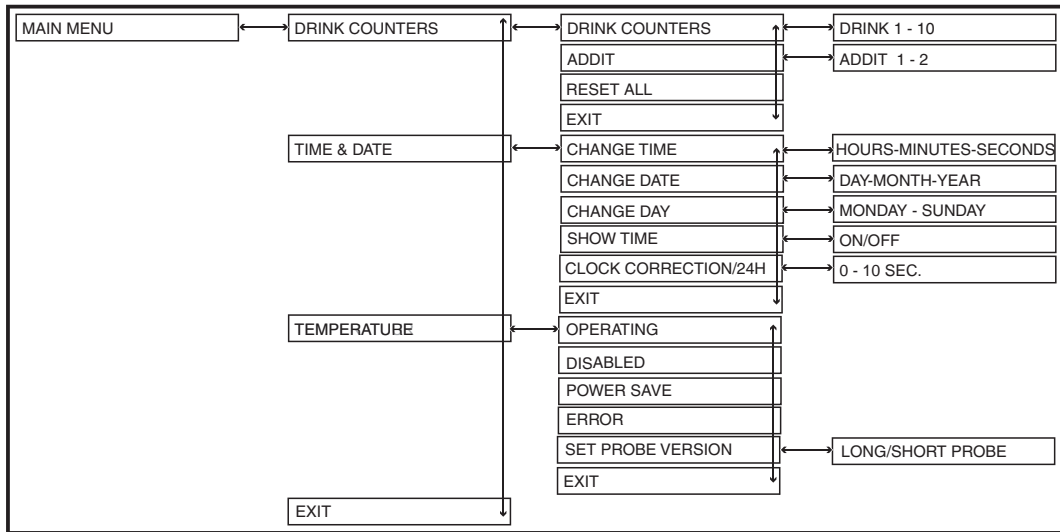

Figure 5-3

5.2 Service engineer menu

Press # on the service panel and enter the PIN code.

The standard pin code for the service engineer menu is **4231**.

Menu subject	Description
Drink settings	- changing the drink settings
Drink counters	- reading the drink counters
Machine counters	- reading the machine counters
Cleaning counters	- reading the cleaning counters for the mixers
Time & date	- changing the time and date settings
Timer functions	- changing the settings for the time function
Temperature	- changing the temperature settings
Error settings	- setting the machine warnings
Settings	- setting the machine parameters
Payment system	- setting the payment system
Pin code	- changing the pin codes

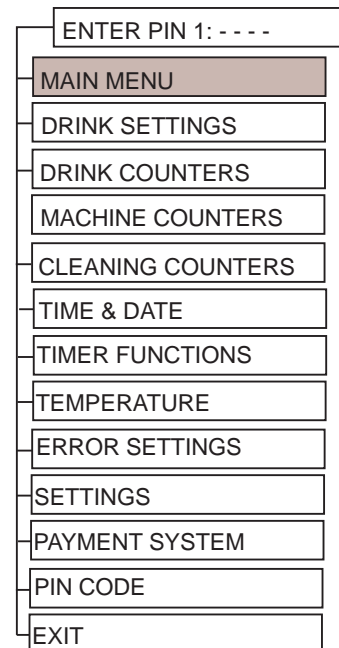

Figure 5-4

5.3 Electrical diagram

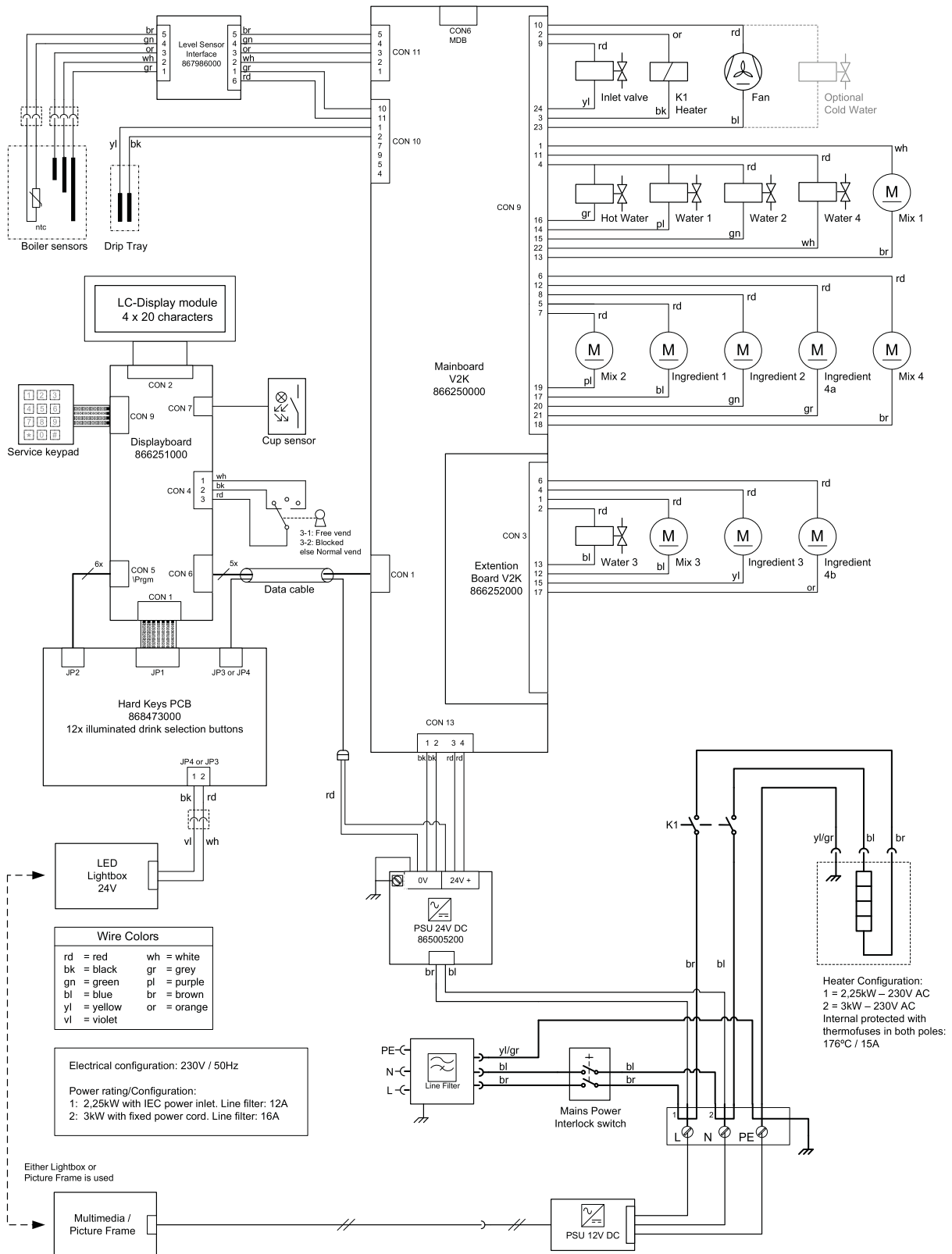

Figure 5-5

5.4 Water flow diagram

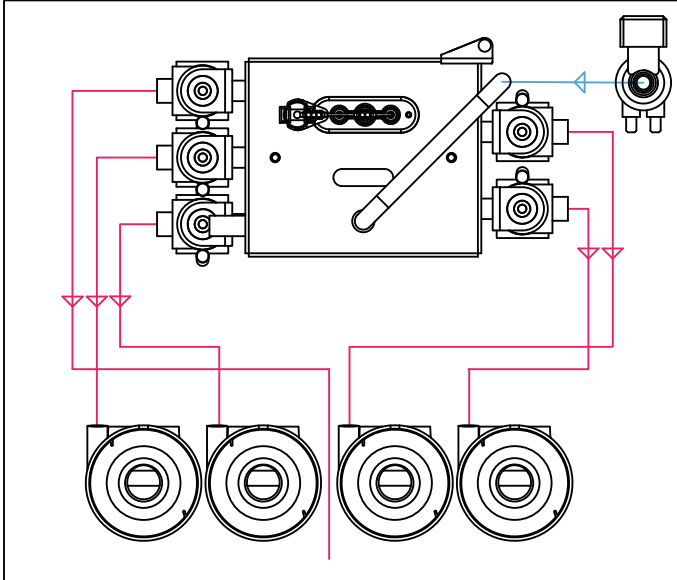

Figure 5-6

6 TECHNICAL SPECIFICATIONS

6.1 Electrical system



Refer to the machine type place for the correct configuration of your machine, see Chapter 1: Machine Identification.

Description	Value
Main voltage	230 V
Frequency	50 Hz
Capacity	2.31 kW
Fuse	16 A

6.2 Water system

Description	Value
Water connection	G 3/4" - outer ring
Minimum water pressure	1.5 bar (150 kPa)
Maximum permitted water pressure	8 bar (800 kPa) ¹

1. If the pressure is higher, a pressure reducer must be installed.

6.3 Sound level

Description	Value
In operation	max. 70 dB(A)



Measurements according to DIN 45635, with normal use.

6.4 Ambient conditions

Description	Value
Ambient temperature	5 - 40 °C



Never place the machine in a room in which the temperature may drop below 0 °C. This is to keep the water in the machine from freezing.

6.5 Dimensions and weight

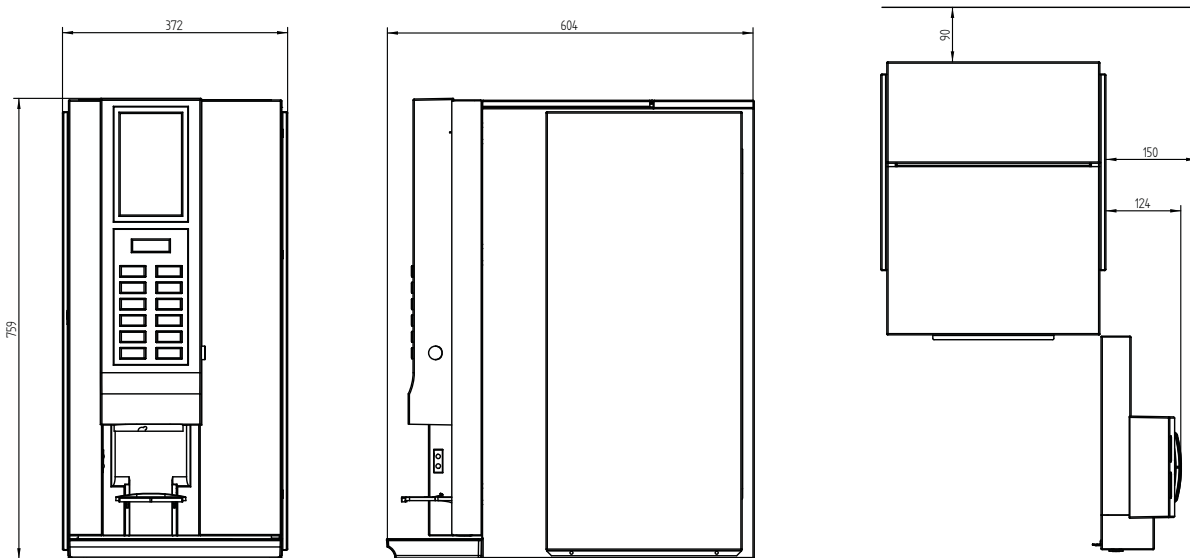

Figure 6-1

Description	Value
Height	759 mm
Width	372 mm
Depth	604 mm
Weight when empty	38 kg
Weight when full	42.5 kg

7 SOFTWARE

7.1 Software versions

Machine software
Version 2.22, display version 1.19

7.2 Levels

The software in the machines has two levels:

- User
- Service engineer

Each level has its own specific options and possibilities. You can access the levels by pressing # on the service panel. The standard pin codes for the operator and service engineer are:

Level	Pin code
User	4321
Service engineer	4231

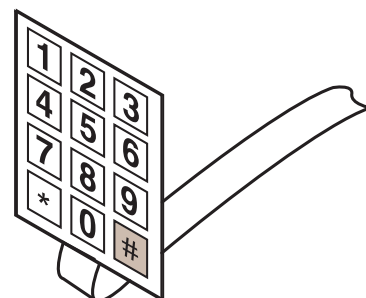

Figure 7-1

7.3 User menu (Operator)

Press # on the service panel and enter the PIN code.

The standard PIN code for the user menu is **4321**.

Menu subject	Description
Drink counters	- reading the counter settings per drink - resetting the counter settings
Time & date	- changing time - changing date - changing day - switching on/off on display - setting time adjustment
Temperature	- changing the temperature (set water default 100°C, coffee water default 90°C, range 80-100°C) - setting the sensor

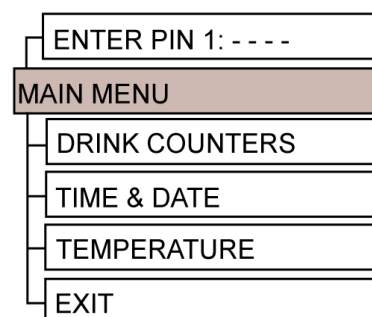

Figure 7-2

7.4 Service engineer menu

Press # on the service panel and enter the PIN code.

The standard pin code for the service engineer menu is **4231**.

Menu subject	Description
Drink settings	- changing the drink settings
Drink counters	- reading the drink counters
Machine counters	- reading the machine counters
Cleaning counters	- reading the cleaning counters for the mixers
Time & date	- changing the time and date settings
Timer functions	- changing the timer functions
Temperature	- changing the temperature settings
Error settings	- setting the machine warnings
Settings	- setting the machine parameters
Payment system	- setting the payment system
Pin code	- changing the pin codes

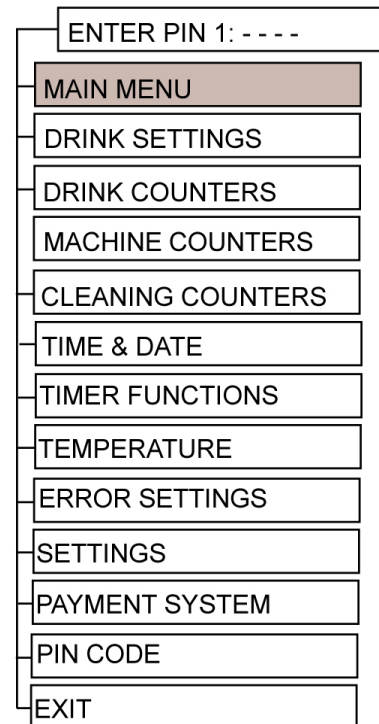

Figure 7-3

7.5 Drink settings

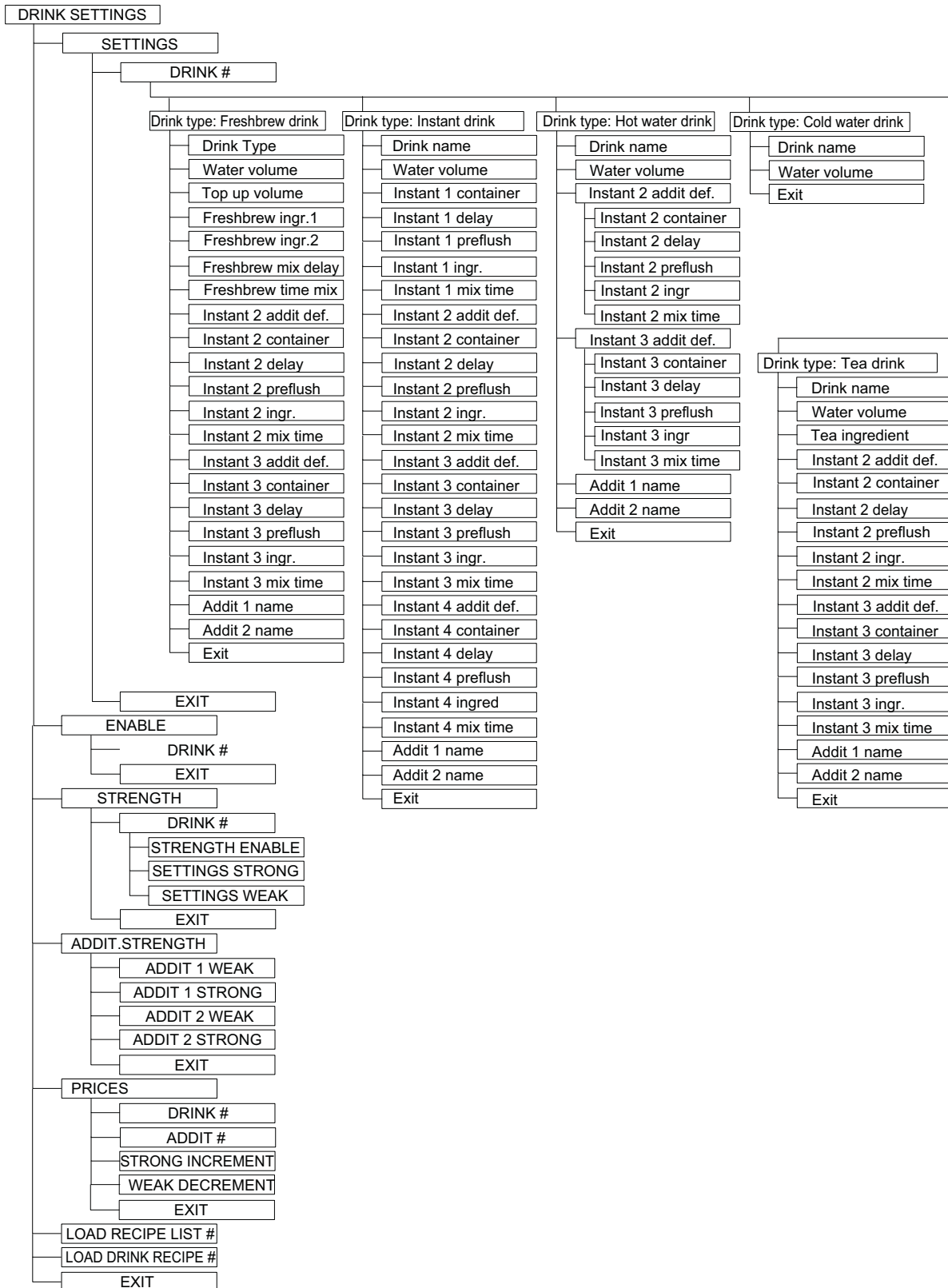

Figure 7-4

Menu subject	Description	Remarks
Settings	- changing the drink settings per drink; drinks 1-8	setting the recipe
Enable	- enabling/disabling drink; drinks 1-8	on/off
Strength	- changing the drink strength per drink; drinks 1-8	enable on/off strong 1-30% weak 1-30%
Additional strength	- changing the additional strength per drink; addition 1-2	weak 1-30% strong 1-30%
Prices	- changing the prices per drink/additions	- addition 1-2 - drink 1-8 - strong increment - weak decrement between 0 and 1000
Load recipe list	- load recipe list; 1-22	
Load drink recipe	- load drink recipe; drink 1-8	

7.5.1 Setting drink recipes



Figure 7-5

Menu subject	Description	Remarks
Drink type	- selecting drink type	Fresh brew drink Instant drink Hot water drink Cold water drink Tea drink
Drink name	- selecting name	
Water volume	- entering water volume in seconds	1 sec = ±25 ml water
Top up volume level		
1st ingredient	- select the 1st ingredient required to be dosed	Not for cold water drink
Instant container	- select the desired instant container	

Menu subject	Description	Remarks
Next ingredient	- select the next ingredients required to be dosed 2-5	Not for cold water drink
Delay	- entering delay in seconds	
Mix time	- entering mix time in seconds	
Preflush	- entering preflush time in seconds	
Instant x additive definition	- entering additives	Milk and/or sugar
Addit x name	- select the name of the additive desired	

7.6 Drink counters

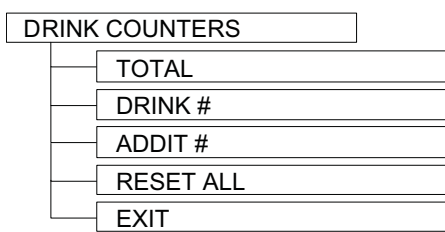

Figure 7-6

Menu subject	Description
Drink counters	- reading the counter settings per drink
Total	- reading total statuses
Drink	- reading counter per drink
Addit	- reading counter for additions
Reset all	- reset all counters

7.7 Machine counters

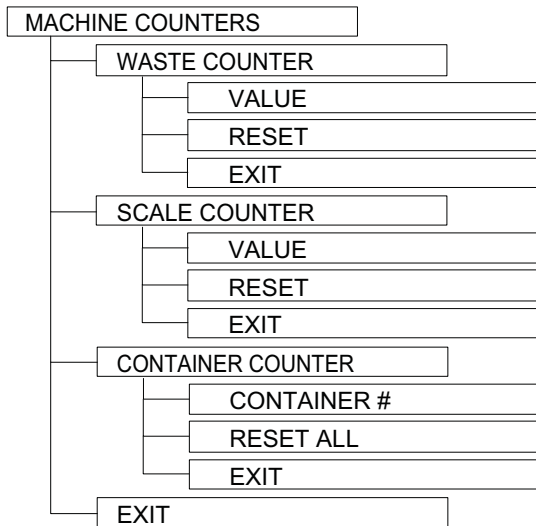

Figure 7-7

Menu subject	Description	Remarks
Machine counters	- reading the machine counters	
Waste counter	- reading/resetting waste counter	standard value 0
Scale counter	- reading/resetting scale counter	standard value 0
Container counter	- reading/resetting container	standard value 0

7.8 Cleaning counters



Figure 7-8

Menu subject	Description
Cleaning counters	- reading cleaning counter
Brewer	- reading/resetting brewer counter
Mixer	- reading/resetting mixer counter per mixer

7.9 Time & date

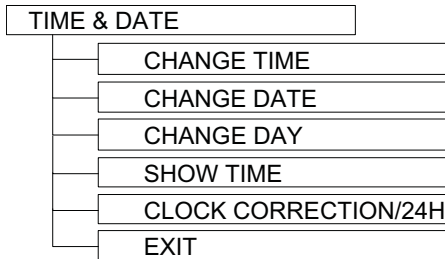

Figure 7-9

Menu subject	Description	Remarks
Time & date	- setting time and date	
Change time	- changing the time	Select item hours and minutes
Change date	- changing the date	Select item day, month and year
Change day	- changing day	Select item Monday-Sunday
Show time	- changing show time	on/off
Clock correction/24 hours	- time adjustment of clock per 24 hours	0-10 sec

7.10 Timer functions

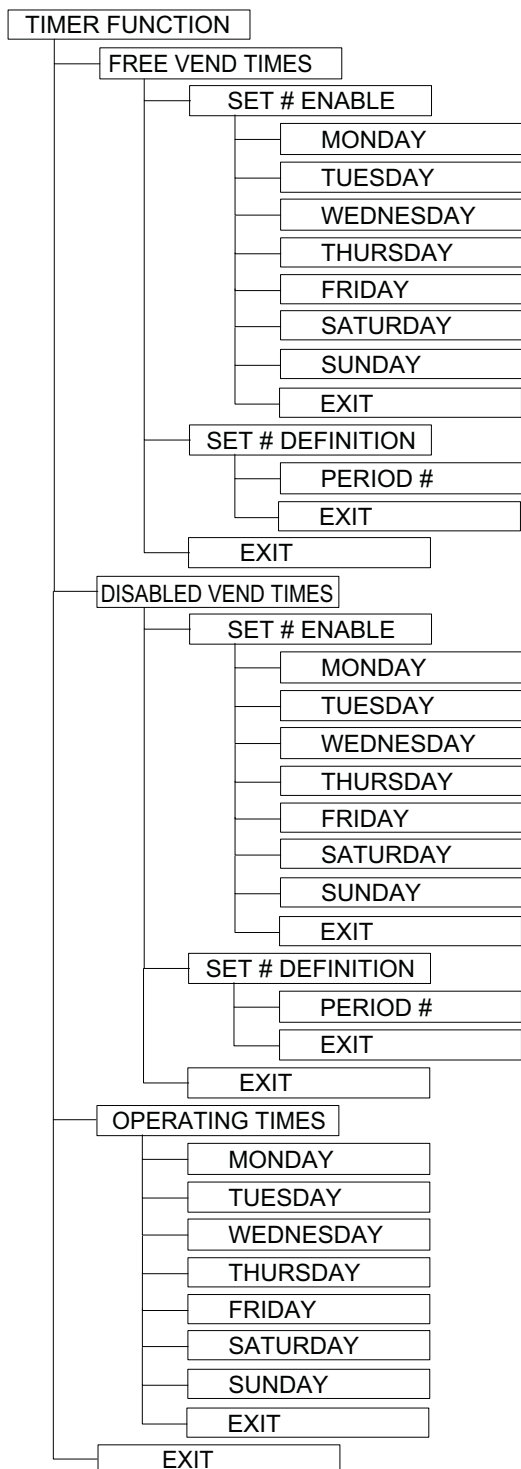

Figure 7-10

Menu subject	Description	Remarks
Timer functions	- setting time functions	
Free vend times	- Set the free vend days and times	Set 1-2 enable Monday-Sunday Set 1-2 defining period 1-10 (00.00 - 23.59)
Disabled vend times	- set the disabled days and times	Set 1-2 enable Monday-Sunday Set 1-2 defining period 1-10 (00.00 - 23.59)
Operating times	- set the working days	Monday-Sunday 07.00-19.00

7.11 Temperature

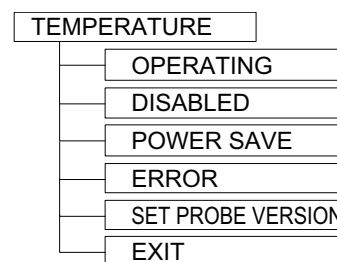

Figure 7-11

Menu subject	Description	Remarks
Temperature	- setting temperature	
Operating	- setting temperature in operation	standard 95°C
Disabled	- setting temperature for when disabled	standard 70°C
Power save	- setting temperature for power save	standard 60 °C
Error	- setting water temperature boiler too low	standard 81°C
Set Probe version	- setting probe version	long/short version

7.12 Error settings

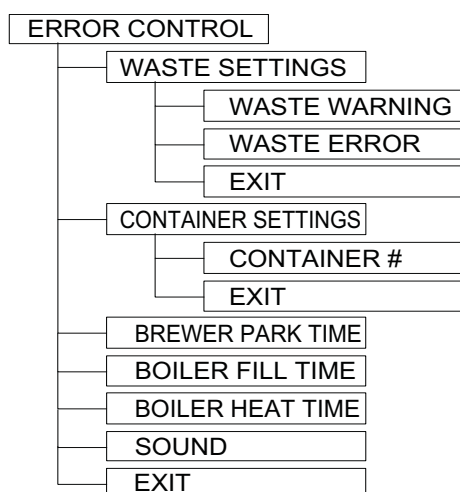

Figure 7-12

Menu subject	Description	Remarks
Error settings	- setting error messages	
Waste settings	- setting error message for waste bucket counter	Not for instant waste warning (0-60) waste error (0-60)
Container setting	- setting error message for container delivery	container 1-5 (0-2500 sec)
Brewer park time	- setting error message for brewer park time	1-150 (40 sec)
Boiler fill time	- setting error message for boiler fill time	0-150 (100 sec)
Boiler heat time	- setting error message for boiler heat time	0-150 (25 min.)
Sound	- setting sound for error message	on/off

7.13 Installation

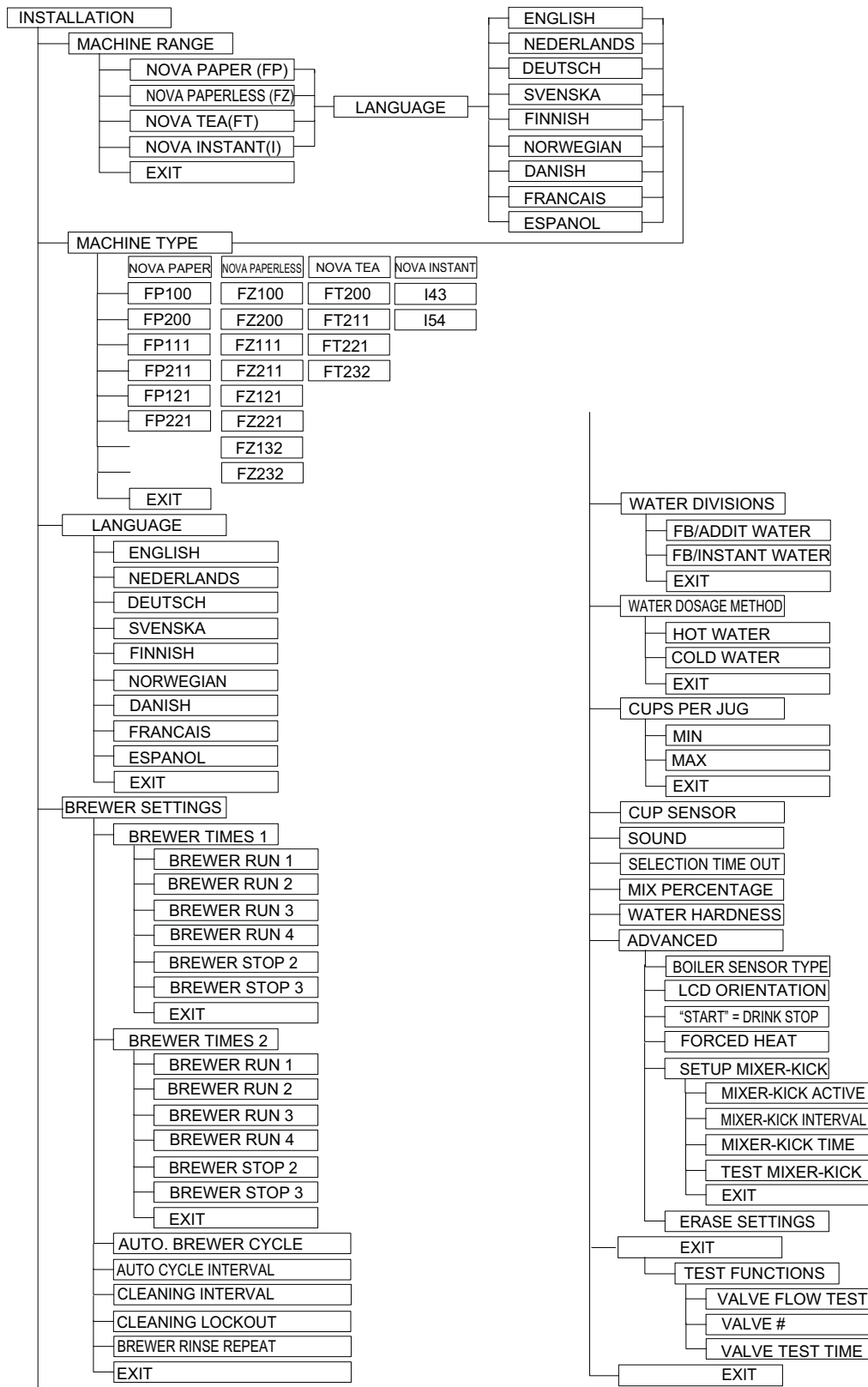

Figure 7-13

Menu subject	Description	Remarks
Installation	- settings for the machine	
Machine range	- setting machine type and language	
Machine type	- setting machine type	
Language	- setting language	
Brewer settings (where applicable)	- brewer times 1-2	brewer run 1-4 0.0 - 20.0 (0.4) brewer stop 2-4 0.0 - 20.0 (1.0)
	- auto brewer cycle	on/off
	- auto cycle interval	0 - 24 hours (6 hour)
	- cleaning interval	
	- cleaning lockout	
	- brewer repeat rinse	
Water division	- setting water division	FB/additional water 10% - 80% (30%) FB/instant water 10% - 80% (30%)
Water dosage method	- setting water dosage	hot water: dosed/maximised (dosed) cold water: dosed/maximised (dosed)
Cups per jug	- setting number of cups per jug	min. 1-12 (1) max. 1-12 (12)
Cup sensor	- setting cup sensor	on/off
Sound	- setting sound	on/off
Selection time out	- setting selection time out	0 - 200 sec (30 sec)
Mix percentage	- setting mix percentage	0 - 100% (80%)
Water hardness	- setting water hardness	0 - 50 (0)
Advanced	- boiler sensor type	resistive/float
	- LCD orientation	vertical/horizontal
	- "start" = drink stop	on/off
	- forced heat	0.0 - 3.0 sec (0.0)
	- setting mixer kick	mixer kick enabled on/off interval mixer kick 1 - 10 (4) time mixer kick 0.1 - 0.5 sec (0.1) testing mixer kick

Menu subject	Description	Remarks
Test functions	- setting test functions flaps	flap 1-5 flap test time 0.0 - 10.0 sec (4.0 sec)

7.14 Payment system

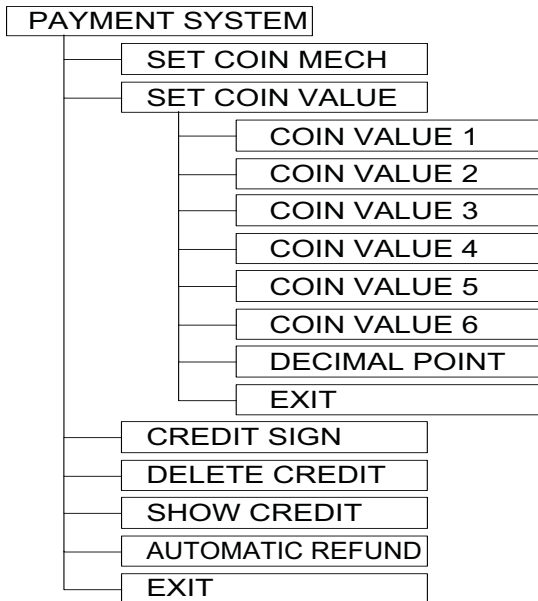

Figure 7-14

Menu subject	Description
Payment system	- setting the payment system
Coin mechanism type	- setting coin mechanism type
Coin values	- setting coin values
Credit sign	- setting credit sign
Delete credit	- setting delete credit
Show credit	- setting show credit
Automatic refund	- setting automatic refund

7.15 Pin code

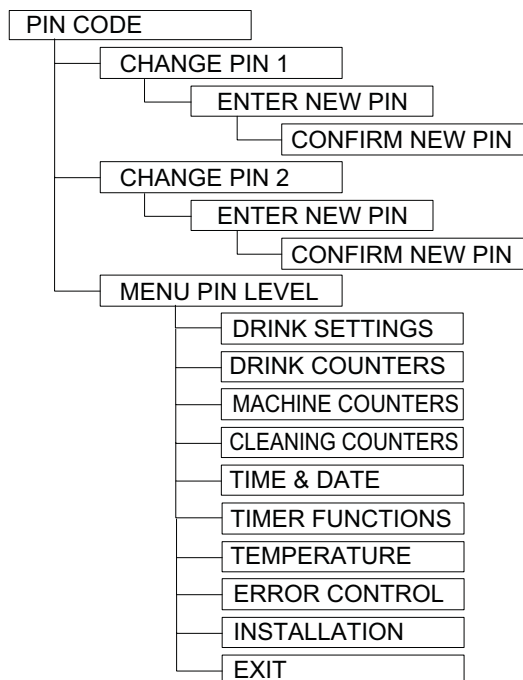

Figure 7-15

Menu subject	Description
Pin code	- setting pin code
Change pin 1	- changing pin code 1
Change pin 2	- changing pin code 2
Menu pin level	- setting which pin applies to which function

7.16 Calibrate the valves



Calibrating the machine requires the following:

- 0.5 l measuring jug
- scales accurate to 0.1 g

- 1 Open the door and insert the service key.
- 2 Determine the weight of the empty measuring jug.
- 3 Place the measuring jug under the dispensing holder.
- 4 Press **#4231** on the service panel; this takes you to the Service engineer menu.
- 5 Go to Installation and press Start.
- 6 Go to Test functions and press Start.
- 7 Check the Valve test time; this must be 4.0 sec.
- 8 Scroll through the next items:
 - Select Start valve no.1 and press Start.
 - Select the valve to be calibrated and press Start.
 - Weigh the quantity delivered.
 - Check whether 100 ± 2 ml water is delivered. If more or less water is delivered then the valve must be adjusted; see the adjustment procedure in par. 8.2.
 - Empty the cup.
 - Repeat these steps for each valve.
- 9 Press Exit and press Start.
- 10 Restart the machine; see the restart procedure in par. 9.4.

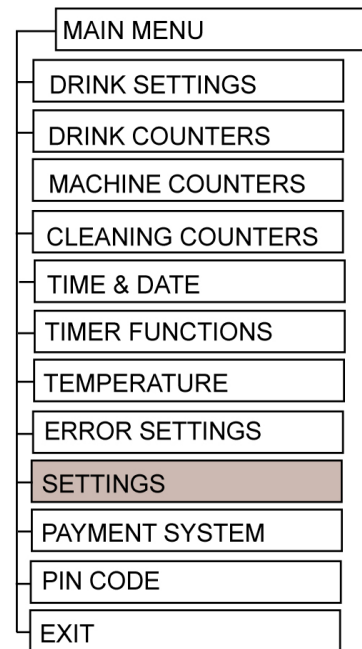

Figure 7-16

8 INSTALLATION

8.1 Connecting the machine

1. Place the machine on a stable and dry surface; see Section 6.
2. Connect to the tap using a water hose with the correct screw thread (3/4 inch BSP) and turn on the tap. Make sure there are no leaks.
3. Electronic safety can only be ensured if a correctly earthed wall socket is used, as prescribed in the requirements regarding electronic safety.
4. The supplier cannot be held responsible if the wall socket does not meet the set safety requirements.
If in doubt as to whether a socket is correctly earthed, please contact a specialist.
If the plug cannot be used with the wall socket, the wall socket must be replaced.
5. The machine must be installed. A password is required for this purpose. This will be provided by your supplier.
6. Close the door.
 - Wait until the software is ready.
 - The display shows the message when this status is reached.



The supplier cannot be held responsible for damage to the machine resulting from incorrect handling.

8.2 Adjusting the valve



All boiler parts and the water from the boiler are hot.

- 1 Open the door.
- 2 Access the machine; see par. 9.2.2. Remove the rear panel.
- 3 Twist the adjusting screw on the valve using a 5 mm Allen key.
- 4 Close the rear panel.
- 5 Close the door.

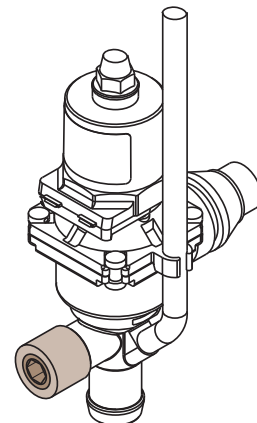

Figure 8-1

8.3 Test the buttons



The Shift button has a different test function.

1. Press # on the service panel and enter the PIN code.
2. Press 9.
 - All the lights under the buttons will light up.
 - The display will show: BUTTON/LED TEST
Press any button
Restart: "1"
Exit: "0"
3. Press any button and the light underneath will go out.
4. Press the same button again and the light underneath will light up again.
5. The Shift button has a different test function: pressing it turns the lights in sequence to white/green/red/deliver left/delivery right. The light under the Shift button does not go out.
6. Press 1 on the service panel to restart.
7. Press 0 on the service panel to stop the test.

9 REPLACEMENT OF PARTS

9.1 Safety requirements - replacing parts



Remove the plug from the wall socket before repairing or replacing any part.

- See also par. 3.1.
- Check the wiring for damage before beginning the repair work.
- Do not re-use self-locking materials and hose clips.
- Ensure everything is clean and dry again after the repair work.

9.2 Repairs



Remove the plug from the socket before carrying out a repair.

Close the water tap and disconnect the water supply hose, where applicable.

Position the machine so that there is easy access to the left and right sides and the rear.

9.2.1 Access to the machine



Be careful when moving the machine. The machine is heavy, see par. 6.5.

- 1 Read the safety instructions, see par. 9.1.
- 2 Remove the plug from the socket.

9.2.2 Removing the plating



Be careful when moving the machine. The machine is heavy, see par. 6.5.



All boiler parts and the water from the boiler are hot.

- 1 Access the machine; see par. 9.2.1.
- 2 Remove the drip tray.
- 3 Open the upper lid.

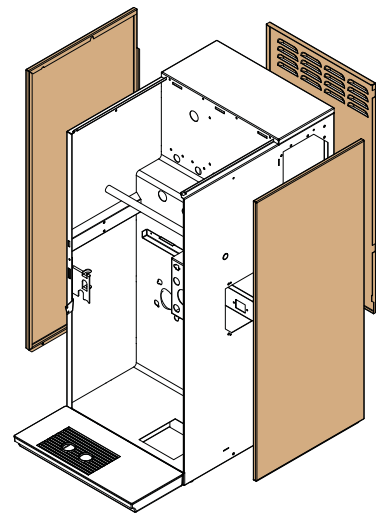

Figure 9-1

Accessing the rear of the machine:

- 1 Remove the two screws on the top.
- 2 Lift the rear plate and remove from the machine.

Accessing the left side of the machine:

- 1 Remove the two screws on the bottom.
- 2 Lift the left side plate approximately 40 mm.
- 3 Rotate the plate clockwise off the machine. Remove the plate from the machine.

Accessing the right side of the machine:

- 1 Remove the two screws on the bottom.
- 2 Lift the right side plate approximately 40 mm.
- 3 Rotate the plate anti-clockwise off the machine. Remove the plate from the machine.

9.3 Emptying the boiler



All boiler parts and the water from the boiler are hot.

- 1 Close the water tap.
- 2 Open the door.
- 3 Access the machine; see par. 9.2.2. Remove the rear panel.
- 4 Remove the discharge hose D from the holder and hang it safely in a bucket E (min. 10 litre).
- 5 Open the hose clip B and empty the boiler.
- 6 Replace the discharge hose in the holder.
- 7 Place the hose clip on the discharge hose.
- 8 Close the rear panel.
- 9 Close the door.

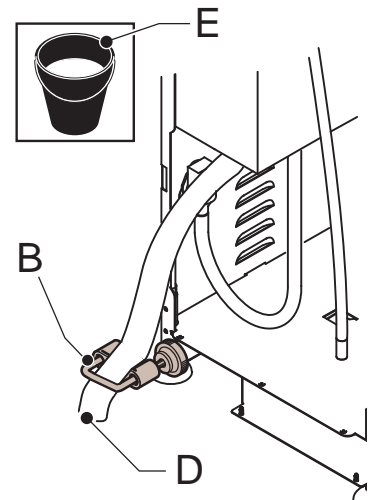

Figure 9-2

9.4 Restarting

- 1 Check that the wiring has been connected correctly.
- 2 Check that the hoses and flaps have been connected correctly.
- 3 Replace the plating on the machine.
- 4 Connect the water supply hose again (where applicable) and open the tap.
- 5 Reconnect the mains.
- 6 Carry out the daily maintenance; see par. 4.5.
- 7 Close the door.
 - Wait until the software is ready.
 - The display shows the message when this status is reached.
- 8 Check the machine for leaks.
- 9 The machine is ready for use again.

9.5 Drink selection labels

- 1 Remove the relevant button by gripping it between your thumb and index finger and pulling it backwards and to the right.

The drink label is loose inside the button.

- 2 Remove the existing drink label.
- 3 Apply the new label.

Make sure that the label is positioned correctly.

- 4 Replace the button by pressing it on the relevant position on the machine. Check that the button is positioned correctly, that it is correctly attached and that it can be pressed in.

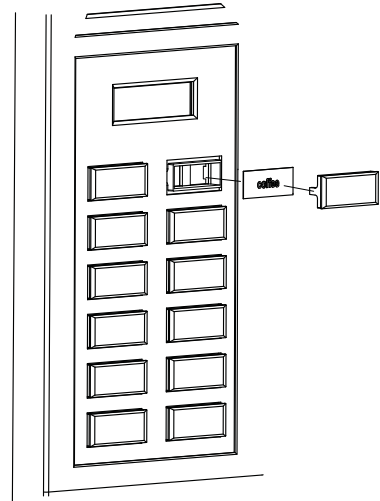

Figure 9-3

9.6 Replacing the inlet valve

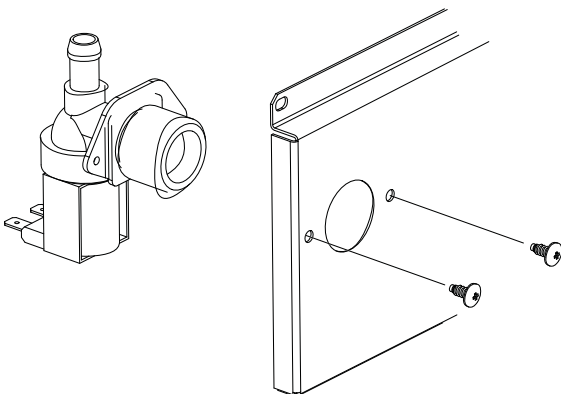

Figure 9-4

- 1 Empty the boiler, see par. 9.3.
- 2 Remove the plating on the right side, see par. 9.2.2.
- 3 Disconnect the wiring from the inlet valve.
- 4 Disconnect the water hoses from the inlet valve.
- 5 Unscrew the two screws from the inlet valve.
- 6 Replace the inlet valve.
- 7 Connect the water hose to the inlet valve.
- 8 Connect the wiring to the inlet valve.
- 9 Restart the machine; see the restart procedure in par. 9.4.

9.7 Replacing the boiler



All boiler parts can be hot and the water from the boiler is hot.

- 1 Empty the boiler, see par. 9.3
- 2 Remove the plug from the wall socket so that the machine carries no voltage.
- 3 Close the water tap.
- 4 Remove the right panel and the rear panel; see par. 9.2.2
- 5 Remove the valves from the boiler; leave the wiring and hoses in place.
- 6 Twist the boiler out of the machine.
- 7 Disconnect the wiring from the boiler sensor and the heating element.



Make a note of how the wiring is connected.

- 8 Disconnect the inlet pipe from the boiler.
- 9 Disconnect the overflow hose from the boiler.
- 10 Disconnect the discharge hose from the boiler.
- 11 Remove the cover insulation and the boiler lid.

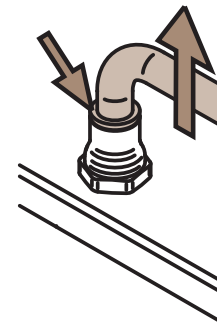

Figure 9-5

- 12 Remove the heating element.

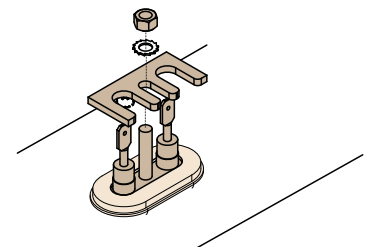

Figure 9-6

13 Remove the boiler sensor (1) and the sealing ring (2).

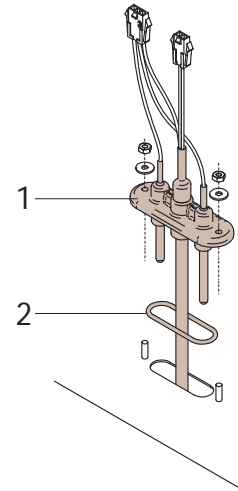

Figure 9-7

14 Remove the boiler by removing the bottom screw (3) and pushing the boiler upwards.

15 Position the new boiler and fit the bottom screw.

16 Fit the heating element on the lid.

17 Fit the boiler sensor (1) on the lid; pay attention to the sealing ring (2) during this process.

18 Position the boiler lid and the cover insulation.

19 Connect the discharge hose to the boiler.

20 Connect the overflow hose to the boiler.

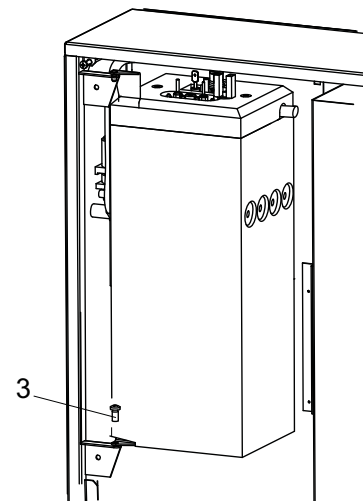

Figure 9-8

21 Connect the inlet pipe to the boiler.

22 Connect the wiring for the boiler sensor and the heating element.

23 Twist the boiler back into the machine.

24 Replace the valves in the boiler, ensuring that the wiring and hoses are securely attached and not kinked.

25 Restart the machine; see the restart procedure in par. 9.4

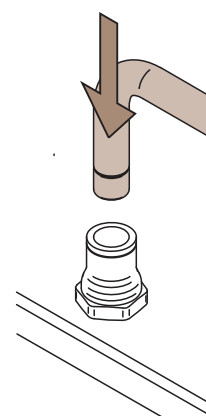

Figure 9-9

9.8 Replacing the boiler sensor



All boiler parts can be hot and the water from the boiler is hot.

- 1 Empty the boiler, see par. 9.3.
- 2 Remove the plug from the wall socket so that the machine carries no voltage.
- 3 Close the water tap.
- 4 Remove the right panel and the rear panel; see par. 9.2.2.
- 5 Remove the valves from the boiler; leave the wiring and hoses in place.
- 6 Twist the boiler out of the machine.
- 7 Disconnect the wiring from the boiler sensor and the heating element.



Make a note of how the wiring is connected.

- 8 Remove the boiler sensor.
- 9 Fit the new boiler sensor (1) on the lid; pay attention to the sealing ring (2) during this process.
- 10 Position the boiler lid and the cover insulation.
- 11 Connect the wiring for the boiler sensor and the heating element.
- 12 Twist the boiler back into the machine.
- 13 Replace the valves in the boiler, ensuring that the wiring and hoses are securely attached and not kinked.
- 14 Restart the machine; see the restart procedure in par. 9.4.

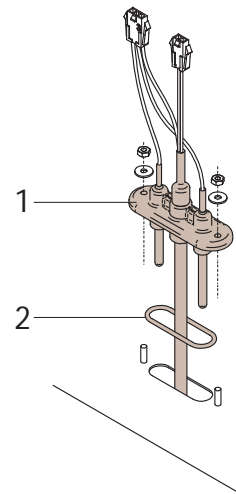

Figure 9-10

9.9 Replacing the heating element



All boiler parts can be hot and the water from the boiler is hot.

- 1 Empty the boiler, see par. 9.3.
- 2 Remove the plug from the wall socket so that the machine carries no voltage.
- 3 Close the water tap.
- 4 Remove the right panel and the rear panel; see par. 9.2.2.
- 5 Remove the valves from the boiler; leave the wiring and hoses in place.
- 6 Twist the boiler out of the machine.
- 7 Disconnect the wiring from the boiler sensor and the heating element.



Make a note of how the wiring is connected.

- 8 Disconnect the inlet pipe from the boiler.
- 9 Disconnect the overflow hose from the boiler.
- 10 Disconnect the discharge hose from the boiler.
- 11 Remove the cover insulation and the boiler lid.

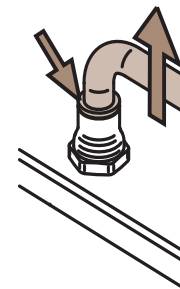

Figure 9-11

- 12 Remove the heating element.
- 13 Fit the new heating element on the lid.
- 14 Fit the boiler lid and the cover insulation.
- 15 Connect the discharge hose to the boiler.
- 16 Connect the overflow hose to the boiler.

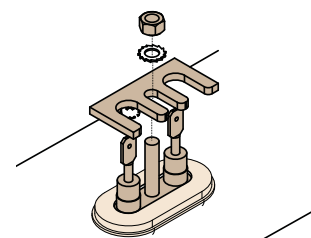

Figure 9-12

- 17 Connect the inlet pipe to the boiler.
- 18 Connect the wiring for the boiler sensor and the heating element.
- 19 Twist the boiler back into the machine.
- 20 Replace the valves in the boiler, ensuring that the wiring and hoses are securely attached and not kinked.
- 21 Restart the machine; see the restart procedure in par. 9.4.

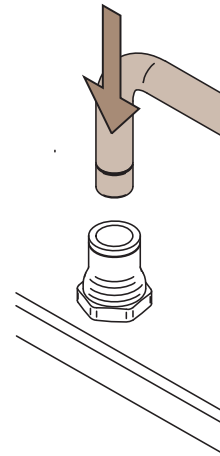

Figure 9-13

9.10 Replacing the valve



All boiler parts can be hot and the water from the boiler is hot.

- 1 Empty the boiler, see par. 9.3.
- 2 Remove the plug from the wall socket so that the machine carries no voltage.
- 3 Close the water tap.
- 4 Remove the rear panel; see par. 9.2.2.
- 5 Remove the valve from the boiler; leave the wiring and hoses in place.
- 6 Disconnect the wiring from the valve.



Make a note of how the wiring is connected.

- 7 Disconnect the hoses from the valve.
- 8 Connect the hoses for the valve.
- 9 Connect the wiring for the valve.
- 10 Position the valve on the boiler, ensuring that the wiring and hoses are securely attached and not kinked.
- 11 Calibrate the valves; see procedure par. 7.16.

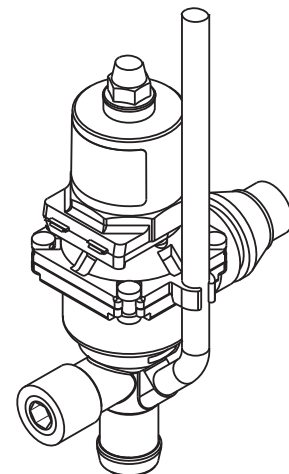

Figure 9-14

9.11 Replacing the extraction fan

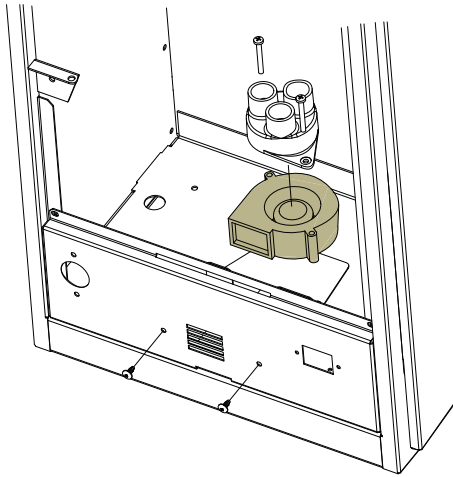

Figure 9-15

- 1 Access the machine; see par. 9.2.1.
- 2 Remove the plating on the rear, see par. 9.2.2.
- 3 Remove the exhaust hoses.
- 4 Remove the two screws from the manifold for the exhaust hoses.
- 5 Remove the manifold from the exhaust hoses.
- 6 Disconnect the wiring from the fan.
- 7 Remove the two screws from the fan fixing.
- 8 Replace the fan.
- 9 Fit the fan fixing with the two screws.
- 10 Connect the wiring.
- 11 Fit the manifold from the exhaust hoses.
- 12 Replace the exhaust hoses.
- 13 Restart the machine; see the restart procedure in par. 9.4.

9.12 Replacing the mixer engine

Removing the mixer engine

- 1 Remove the mixer parts, see para. 4.6.1.
- 2 Access the machine; see par. 9.2.1.
- 3 Remove the plating on the rear, see par. 9.2.2.
- 4 Disconnect the wiring from the engine (rear of the machine).
- 5 Remove the two screws and supports that are used to fit the engine (front of the machine).
- 6 Remove the engine.

Fitting the mixer engine

- 1 Position the engine in the installation holes from the rear.
- 2 Fit the supports and screw the engine in place (front of the machine).
- 3 Reconnect the wiring for the engine (rear of the machine).
- 4 Position the mixer parts, see para. 4.6.1.
- 5 Restart the machine; see the restart procedure in par. 9.4.

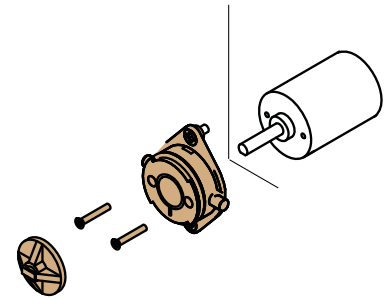

Figure 9-16

9.13 Replacing the ingredient engine

Removing the ingredient engine

- 1 Access the machine; see par. 9.2.1.
- 2 Remove the plating on the rear, see par. 9.2.2.
- 3 Only remove the boiler if necessary; see par. 9.7.
- 4 Open the door of the machine.
- 5 Remove the containers.
- 6 Remove the gear wheel for the relevant engine axle.
- 7 Disconnect the connector from the engine (rear of the machine).
- 8 Remove the four screws that are used to fit the engine.
- 9 Remove the engine by sliding it to the right and downwards under the mounting bracket.

Fitting the ingredient engine

- 1 Position the engine in the mounting bracket from below.
- 2 Screw the engine in place with the four screws.
- 3 Reconnect the connector for the engine.
- 4 Position the gear wheel on the engine axle.
- 5 Position the containers.
- 6 Restart the machine; see the restart procedure in par. 9.4.

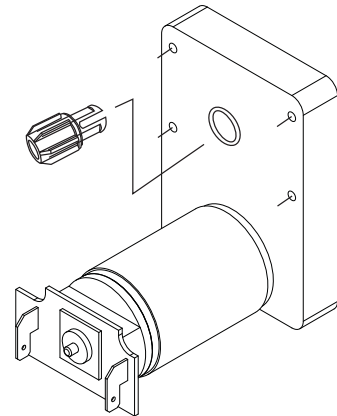

Figure 9-17

9.14 Replacing the espresso mixer

- 1 Access the machine; see par. 9.2.1.
- 2 Open the door of the machine.
- 3 Remove the dispensing holder.
- 4 Remove the mixing chamber.
- 5 Disconnect the connector from the engine.
- 6 Remove the 3 screws that are used to fit the engine.
- 7 Replace the engine including the housing.
- 8 Fit the engine with the 3 screws; pay attention to the position in relation to the hinge.
- 9 Reconnect the connector for the engine.
- 10 Position the mixing chamber.
- 11 Insert the dispensing holder.
- 12 Restart the machine; see the restart procedure in par. 9.4.

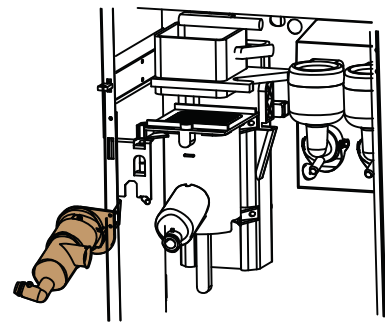

Figure 9-18

9.15 Replacing the drip tray sensor

- 1 Access the machine; see par. 9.2.1.
- 2 Remove the plating on the left side, see par. 9.2.2.
- 3 Disconnect the wiring from the sensor.
- 4 Unscrew the two screws (A) from the sensor fixing.
- 5 Replace the drip tray sensor (B).
- 6 Connect the wiring.
- 7 Restart the machine; see the restart procedure in par. 9.4.

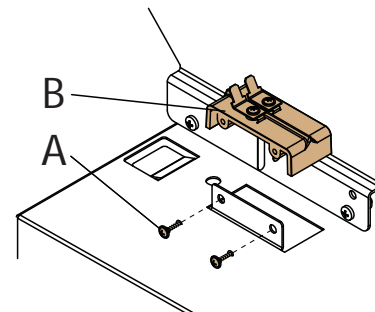

Figure 9-19

9.16 Door plate



Note : The printed circuit boards are ESD sensitive. Use ESD protection before working on these parts. Wear an ESD wristband and connect it to the machine frame.

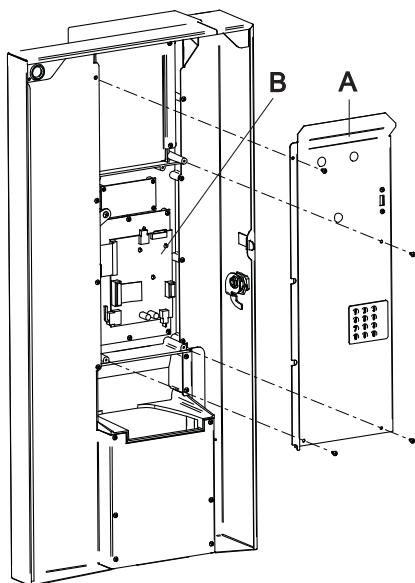

Figure 9-20

- A=Door plate
- B=Display PCB

Removing the door plate

- 1 Access the machine; see par. 9.2.1.
- 2 Unscrew the plate (A).
- 3 Disconnect the flat cable for the service panel from the display PCB (B).
- 4 Remove the plate.

Fitting the door plate

- 1 Connect the flat cable for the service panel to the display PCB (B).
- 2 Fit the plate (A).
- 3 Restart the machine; see the restart procedure in par. 9.4.

9.17 Replacing the cup sensor



Note : The printed circuit boards are ESD sensitive. Use ESD protection before working on these parts. Wear an ESD wristband and connect it to the machine frame.

- 1 Remove the door plate; see par. 9.16.
- 2 Disconnect the sensor connector from the display PCB.
- 3 Unscrew the 2 screws from the sensor fixing.
- 4 Replace the complete sensor.
- 5 Fit the sensor fixing with the 2 screws.
- 6 Connect the sensor connector to the display PCB.
- 7 Fit the door plate; see par. 9.16.

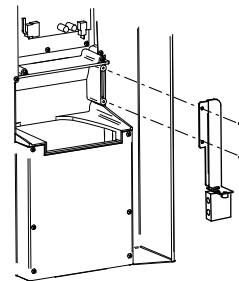

Figure 9-21

9.18 LCD display and display PCB



Note : The printed circuit boards are ESD sensitive. Use ESD protection before working on these parts. Wear an ESD wristband and connect it to the machine frame.

Replacing the LCD display

- 1 Remove the door plate; see par. 9.16.
- 2 Remove the 4 screws from the LCD display (C).
- 3 Remove the LCD display.
- 4 Position the LCD display and align the display with the frame in the door. Position the 4 screws.
- 5 Fit the door plate; see par. 9.16.

Replacing the display PCB

- 1 Remove the door plate; see par. 9.16.
- 2 Detach the display PCB (B) from the 3 clamping pins that are used to attach it.
- 3 Remove the display PCB.
- 4 Position the display PCB by pressing it onto the three clamping pins.
- 5 Connect the connectors to the display PCB (B).
- 6 Fit the door plate; see par. 9.16.

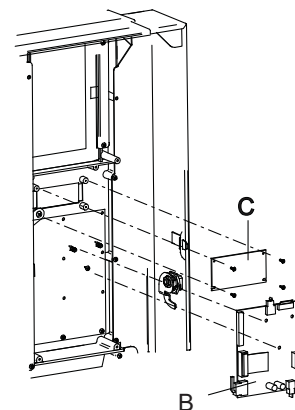

Figure 9-22

9.19 Replacing the selection panel print



Note : The printed circuit boards are ESD sensitive. Use ESD protection before working on these parts. Wear an ESD wristband and connect it to the machine frame.

- 1 Remove the door plate; see par. 9.16.
- 2 Disconnect the connectors from the display PCB (B).
- 3 Detach the display PCB from the 3 clamping pins that are used to attach it.
- 4 Remove the display PCB.
- 5 Disconnect the connector from the selection panel PCB (D).
- 6 Unscrew the 8 screws from the PCB fixing.
- 7 Replace the selection panel PCB.
- 8 Fit the selection panel PCB with the 8 screws.
- 9 Connect the connector to the selection panel PCB.
- 10 Position the display PCB (B) by pressing it onto the three clamping pins.
- 11 Connect the connectors to the display PCB.
- 12 Fit the door plate; see par. 9.16.

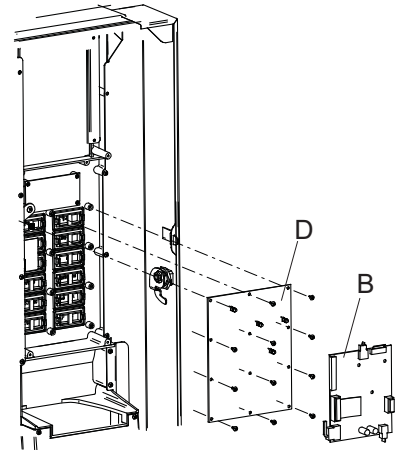

Figure 9-23

9.20 Replacing the illumination panel



Note : The printed circuit boards are ESD sensitive. Use ESD protection before working on these parts. Wear an ESD wristband and connect it to the machine frame.

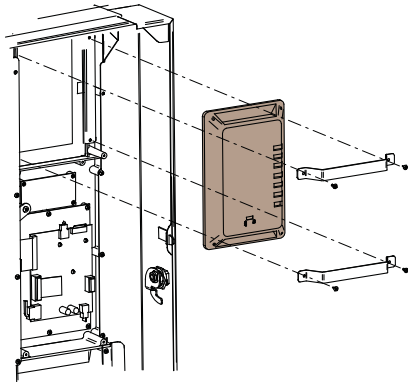

Figure 9-24

- 1 Remove the door plate; see par. 9.16.
- 2 Detach the illumination panel (E) from the 3 clamping pins that attach it to the door plate (A).
- 3 Disconnect the wiring from the illumination panel.
- 4 Replace the illumination panel.
- 5 Connect the wiring for the illumination panel.
- 6 Position the illumination panel by pressing it onto the three clamping pins on the door plate.
- 7 Fit the door plate; see par. 9.16.

9.21 Digital photo frame (optional)



A digital photo frame can also be fitted instead of the standard lighting panel.

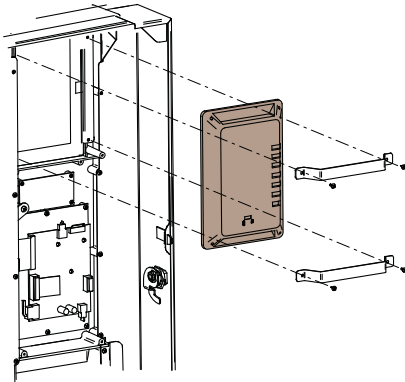

Figure 9-25

Replacing the photo frame

- 1 Remove the door plate; see par. 9.16.
- 2 Disconnect the connector from the photo frame.
- 3 Remove both the brackets that attach the photo frame.
- 4 Replace the photo frame; make sure that the display is positioned correctly.
- 5 Fit both brackets.
- 6 Reconnect the connector to the photo display.
- 7 Fit the door plate; see par. 9.16.

Replacing the power supply for the digital photo frame

- 1 Remove the door plate; see par. 9.16.
- 2 Access the machine; see par. 9.2.1.
- 3 Remove the plating on the right side, see par. 9.2.2.
- 4 Isolate the connectors from the power supply.
- 5 Remove the tie wraps that attach the power supply.
- 6 Replace the power supply.
- 7 Attach the power supply tie wraps.
- 8 Connect the connectors to the power supply.
- 9 Fit the door plate; see par. 9.16.
- 10 Restart the machine; see the restart procedure in par. 9.4.

Operating the photo frame



Please refer to the manuals enclosed for the correct use of the remote control and the digital photo frame.

The photo frame is operated with the remote control.

The photos can be stored on a memory card (SD, MS, MMC, XD). The photos must be in JPG format.

The computer files can be loaded via the USB connection on the door plate (inside of the door).

Photo frame settings

- 1 Press the SETUP button on the remote control or select Setup in the main menu.
- 2 The following settings can be created in the Setup menu:
 - Interval: the time between the photos
 - Transition effect: the transition between the photos
 - Browse mode: searching with thumbnails or file names
- 3 The following settings can be created in the Photo setting menu:
 - Photo: switching the playback of photos on/off
 - Music: n/a
 - Movie: n/a
- 4 The following settings can be created in the Display setting menu:
 - TV standard: NTSC, PAL or Auto
 - Brightness
 - Contrast
 - TFT brightness
 - TFT contrast
 - TFT saturation: saturation of the colours
- 5 The following settings can be created in the Custom setup menu:
 - OSD language: the language setting on the screen
 - UI style: the style of the screen menus
 - Contrast
 - Repeat mode: the repeat setting
 - OFF: repeat off
 - On: repeat file
 - Leaflet: repeat folder
 - All: repeat all files
 - Default: exit to factory settings
 - Exit
- 6 Exit: exit to the main menu

9.22 Replacing the control PCB



Note : The printed circuit boards are ESD sensitive. Use ESD protection before working on these parts. Wear an ESD wristband and connect it to the machine frame.

- 1 Access the machine; see par. 9.2.1.
- 2 Remove the plating on the left side, see par. 9.2.2.
- 3 Disconnect the 5 connectors from the control PCB.
- 4 Detach the control PCB from the 5 clamping pins that attach it to the machine.
- 5 Replace the control PCB.
- 6 Position the control PCB by pressing it onto the 5 clamping pins.
- 7 Connect the 5 connectors to the control PCB.
- 8 Restart the machine; see the restart procedure in par. 9.4.

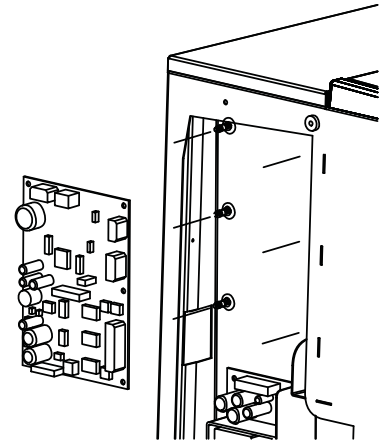

Figure 9-26

9.23 Replacing the level sensor PCB



Note : The printed circuit boards are ESD sensitive. Use ESD protection before working on these parts. Wear an ESD wristband and connect it to the machine frame.

- 1 Access the machine; see par. 9.2.1.
- 2 Remove the plating on the left side, see par. 9.2.2.
- 3 Disconnect the 2 connectors from the level sensor PCB.
- 4 Detach the level sensor PCB from the 2 clamping pins that attach it to the machine.
- 5 Replace the level sensor PCB.
- 6 Position the level sensor PCB by pressing it onto the 2 clamping pins.
- 7 Connect the 2 connectors to the level sensor PCB.
- 8 Restart the machine; see the restart procedure in par. 9.4.

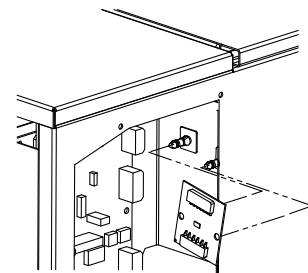

Figure 9-27

9.24 Replacing the power supply



Note : The printed circuit boards are ESD sensitive. Use ESD protection before working on these parts. Wear an ESD wristband and connect it to the machine frame.

- 1 Access the machine; see par. 9.2.1.
- 2 Remove the plating on the left side, see par. 9.2.2.
- 3 Disconnect the 2 connectors from the power supply.
- 4 Remove the 2 fixing screws.
- 5 Detach the power supply from the 2 clamping pins that attach it to the machine.
- 6 Replace the power supply.
- 7 Position the power supply by pressing it onto the 2 clamping pins.
- 8 Position the 2 fixing screws; fit the single wire using the screw at the top left.
- 9 Connect the 2 connectors to the power supply.
- 10 Restart the machine; see the restart procedure in par. 9.4.

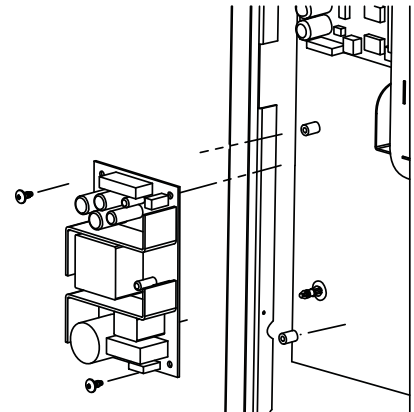

Figure 9-28