



# PALMA H



## General index

### 1.- General Characteristics ----- 3

1.1 Machine Definition -----	3
1.2 Product Container -----	4
1.3 Types of Available Coils -----	5
1.4 Refrigeration -----	8
1.5 Series Models and their Configurations -----	9
1.6 Exterior Communication -----	16
1.7 Instruction Lettering and Operator Data -----	17
1.8 Operation Control -----	17
1.9 Selection Keys -----	17
1.10 Coin Mechanism -----	18
1.11 Sales Prices -----	18
1.12 Coin Acceptance -----	18
1.13 Coin Return -----	19

### 2.- Technical Characteristics ----- 20

2.1 Standards -----	20
2.2 Physical Characteristics -----	20
2.3 Materials and Paints -----	21
2.3.1 Door	
2.3.2 Glass	
2.3.3 Body	
2.3.4 Paint	
2.3.5 Saline Vapour	
2.4 Electrical Specifications -----	23
2.5 Temperature and Relative Humidity -----	24
2.6 Operational Incline -----	24
2.7 Sound Level -----	24

continued..



continued...

**3.- Machine Description ----- 25**

3.1 Door Unit ----- 25  
3.2 Body Unit ----- 26

**4.- Installation and Start-Up ----- 27**

4.1 Electrical Installation ----- 27  
4.2 Levelling ----- 27  
4.3 Ventilation ----- 27  
4.4 Coil Substitution ----- 28  
    4.4.1 Changing Coils  
    4.4.2 Installing a Contrary Coil with a Standard One 28  
4.5 Tray Height Regulation ----- 29  
4.6 Seventh Shelf Installation ----- 29  
4.7 Changing Space between Coils ----- 30  
4.8 Loading Products ----- 30  
    4.8.1 Recommendations for Loading Products  
    4.8.2 Load Tests  
4.9 Product Identification and Price ----- 32  
4.10 Coin Mechanism Installation ----- 33  
4.11 Loading the Coin Returners ----- 34  
4.12 Initial Programming ----- 34  
4.13 Start-Up ----- 35  
4.14 Verifications and Start-Up ----- 35

**5.- Maintenance ----- 35**

5.1 Exterior Cleaning ----- 35  
5.2 Cleaning the Condenser ----- 35

**6.- Service Description ----- 36**

# 1.-General Characteristics

## 1.1 Machine Definition

The models "H" of the **PALMA** series are machines intended for automatic sales of packaged products through the use of coils and are equipped with a cold group permitting their conservation under optimum humidity and temperature.



**PALMA H-70**



**PALMA H-87**

**Figure 1**



## 1.2 Product Container

It can be configured and the maximum product capacity is determined by the number of shelves, the number of coils per shelf and the type of coil used.

	H-70	H-87
MAXIMUN NUMBER OF SELVES	7	7
MAXIMUN NUMBER OF COILS PER SHELF	6	8

Each shelf is associated with a letter (A, B, C ...G) and the position of the coils with another (A, B, C...G). The combination of the two indicates the identification of each coil (AA... AH, BA... BH, ... GA... GH).

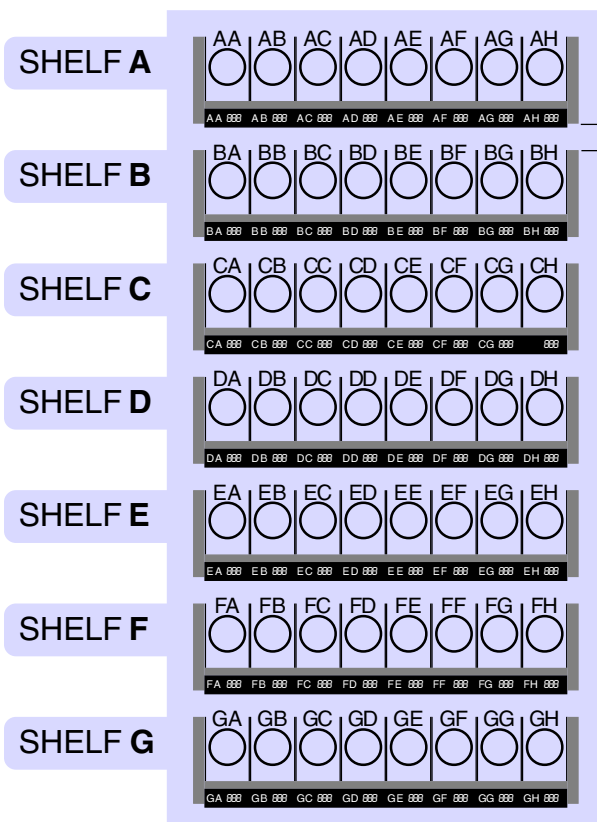

The minimum separation distance between shelves is 52mm.

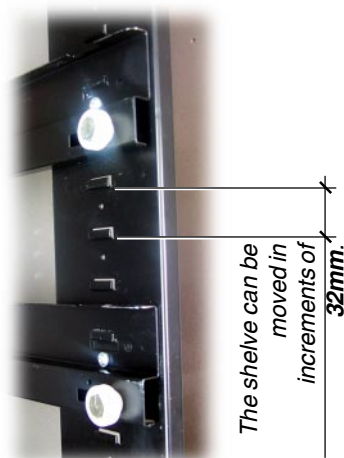
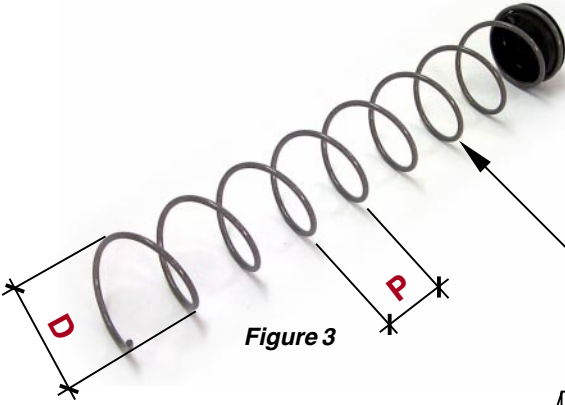

Figure 2

## 1.3 Type of Available Coils

DESIGNATION	Ø HUSILLO (D)	PITCH (P)	WIDTH BETWEEN PARTITIONS (A)	PRODUCT CAPACITY
<b>65-20</b>	65	20	72,5	22
<b>65-25</b>	65	25	72,5	19
<b>65-30</b>	65	30	72,5	15
<b>65-35</b>	65	35	72,5	13
<b>65-40</b>	65	40	72,5	11
<b>65-50</b>	65	50	72,5	8
<b>65-60</b>	65	60	72,5	7
<b>65-85</b>	65	85	72,5	5
<b>65-20 C (Contrary)</b>				
	65 C	20	145 (Coupled with 65-20)	22
<b>65-25 C (Contrary)</b>				
	65 C	25	145 (Coupled with 65-25)	19
<b>65-30 C (Contrary)</b>				
	65 C	30	145 (Coupled with 65-30)	15
<b>65-35 C (Contrary)</b>				
	65 C	35	145 (Coupled with 65-35)	13
<b>65-40 C (Contrary)</b>				
	65 C	40	145 (Coupled with 65-40)	11
<b>65-50 C (Contrary)</b>				
	65 C	50	(Coupled with 65-50)	8
<b>65-60 C (Contrary)</b>				
	65 C	60	(Coupled with 65-60)	7
<b>65-85 C (Contrary)</b>				
	65 C	85	145 (Coupled with 65-85)	5
<b>65-20 D (Double)</b>				
	65 D	20	72,5	44
<b>65-30 D (Double)</b>				
	65 D	30	72,5	30
<b>78-35</b>				
	78	35	145	13
<b>78-45</b>				
	78	45	145	10
<b>78-55</b>				
	78	55	145	8
<b>78-65</b>				
	78	65	145	7
<b>78-85</b>				
	78	85	145	5



The coils are made from  $\varnothing 4\text{mm}$  steel piano wire which is later painted.

Figure 3

The partitions can be moved at 72.5mm increments.

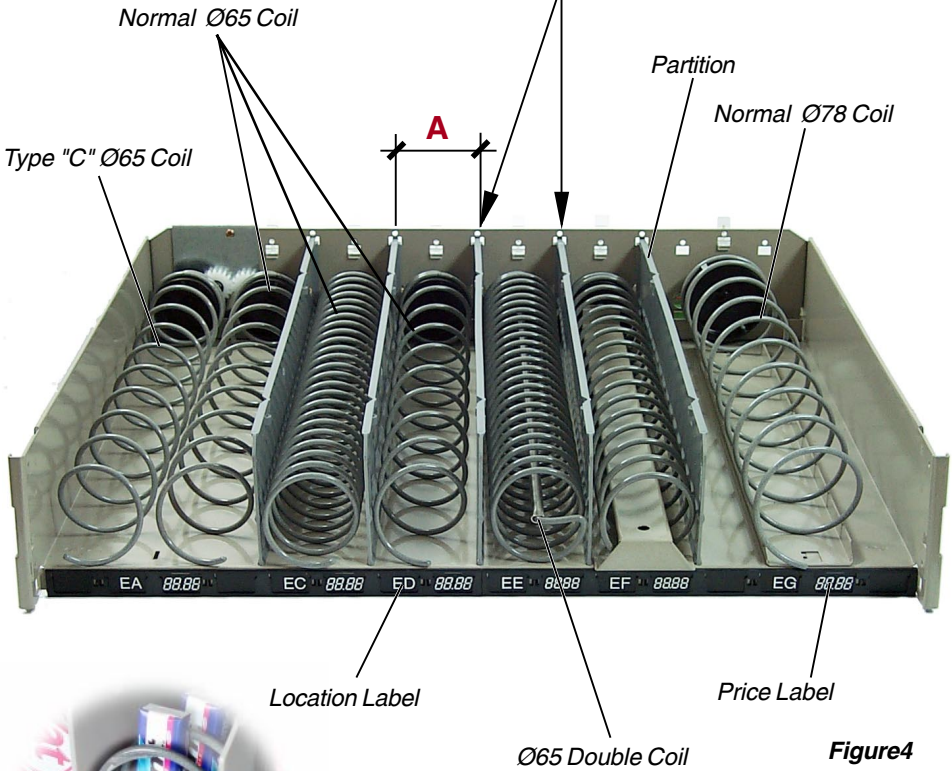

Figure 4

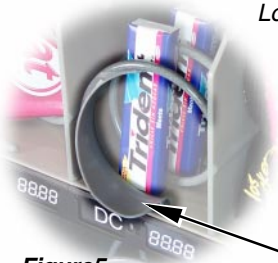

Figure 5

A product expeller can be installed for both  $\varnothing 65$  and  $\varnothing 78$  coils to facilitate product removal.

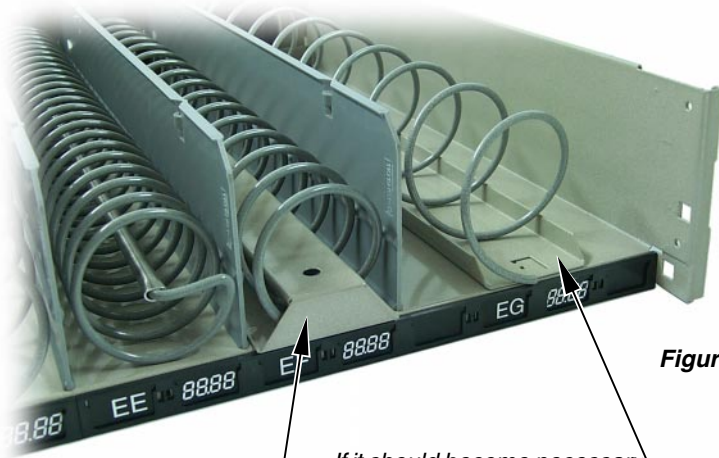

Figure 6

If it should become necessary to move the partition a platform must be used to guide the coils.

All Ø65 coils can be coupled to a platform for the sale of heavy products such as canned beverages, bottles, yogurts, etc.



Figure 7

Long products can also be sold lying flat. To do so, two coils can be used, one being type "C" (contrary). If it is necessary to move the partitions using two coils (one contrary) a platform must be used to guide the coils.



Figure 8

The maximum height of a rigid product (H) that can be extracted is 165mm.



## 1.4 Refrigeration

There is a refrigeration unit that functions with gas refrigerant R-134a, without CFC and equipped with a 12 cm<sup>3</sup>, capable of lowering the temperature of the container to 3 °C with a room temperature of 32 °C without direct sunlight.

**In tests performed at a room temperature of 32 °C, a relative humidity of 75%, and with the product at room temperature, when the machine is connected for the first time it took 3 hours for the products to reach 3 °C.**

The entire container can be maintained at a single temperature or may be divided into two sections with different temperatures.

The temperature is controlled by the Control Card which uses a digital electronic thermometer located in the lower part of the body which continuously monitors the temperature of the product container.

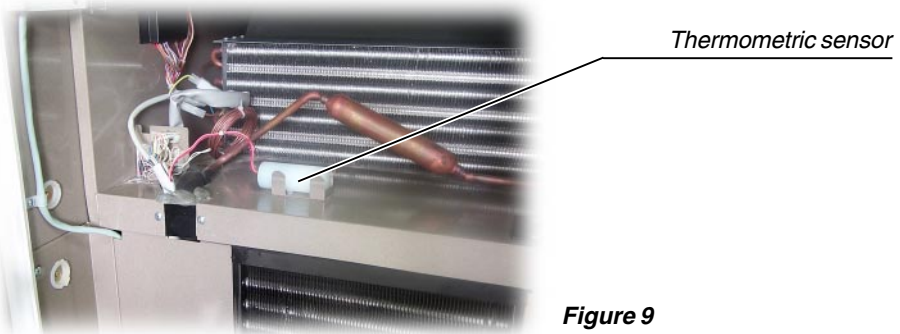

**Figure 9**

When the machine operates at a certain temperature, the minimum programmable temperature is 3 °C. However, the temperature of the product container will vary between 2 °C and 4 °C, that is, the cold group disconnection occurs at 1 °C below the programmed temperature and reconnection at 1 °C above the programmed temperature.

When the container has been divided into two different temperature zones, the minimum possible temperature is 3 °C in the lower section and 12 °C in the upper one. In this case group disconnection will take place when the programmed temperature is reached and reconnection will occur when the temperature surpasses the programmed temperature by 1 °C.

If for any reason the cold group should be functioning continuously for four hours, the control card will automatically disconnect it for 30 minutes to permit defrosting and improve the group's performance.

If the groups stops for temperature reasons, it will remain so for a minimum of 10 minutes and if it does so due to a power outage, the group will take 1 minute to resume operation. All of these measures are designed to improve the group's performance.

# 1.5 Series Models and their Configurations

## PALMA H-87 / 36 Selections / 7 Shelves / 1 Temperature

<b>Shelf A</b>	78-35		78-35		78-35		78-35	
<b>Shelf B</b>	78-35		78-35		78-35		78-45	
<b>Shelf C</b>	78-45		78-45		78-45		78-45	
<b>Shelf D</b>	65-50 C		65-50 C		78-55		78-55	
<b>Shelf E</b>	78-55		78-55		78-65		78-65	
<b>Shelf F</b>	65-20 D	65-20 D	65-20	65-25	65-25	65-30	65-30	65-30
<b>Shelf G</b>	65-20 D	65-20 D	65-20	65-25	65-25	65-30	65-30	65-30

The temperature throughout the container is variable between 3 °C and room temperature

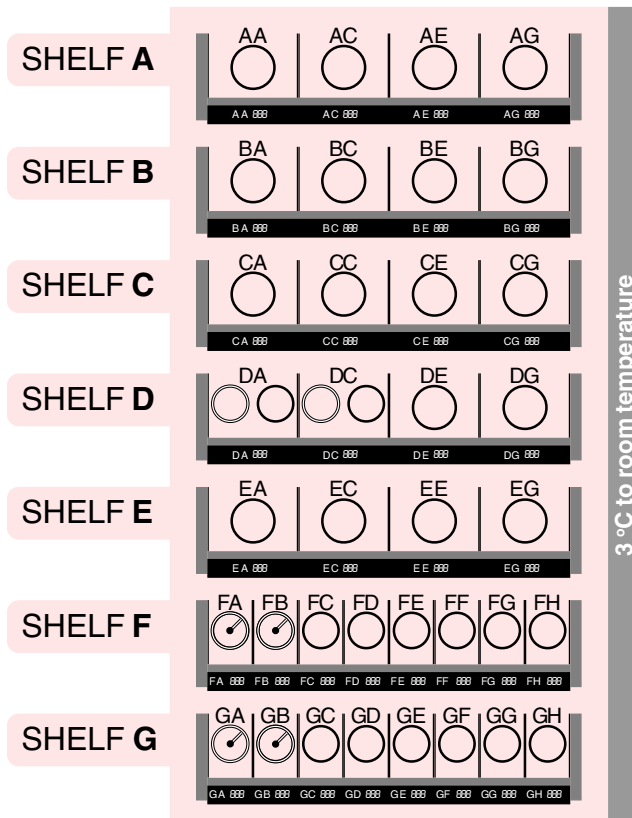



**PALMA H-87 / 28 Selections / 6 Shelves / 1 Temperature**

<b>Shelf A</b>	78-35	78-35	78-35	78-35				
<b>Shelf B</b>	78-35	78-35	78-35	78-45				
<b>Shelf C</b>	78-45	78-45	78-45	78-45				
<b>Shelf D</b>	65-50 C	65-50 C	78-55	78-55				
<b>Shelf E</b>	78-55	78-55	78-65	78-65				
<b>Shelf F</b>	65-20 D	65-20 D	65-20	65-25	65-25	65-30	65-30	65-30

The temperature throughout the container is variable between 3 °C and room temperature

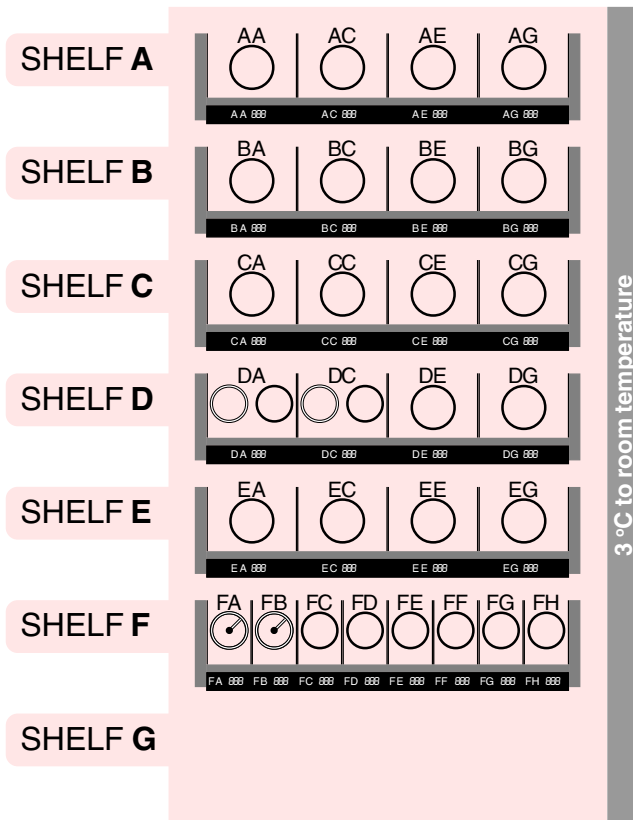

**PALMA H-70 / 21 Selections/ 6 Shelves / 1 Temperature**

<b>Shelf A</b>	78-35		78-35		78-35	
<b>Shelf B</b>	78-35		78-35		78-35	
<b>Shelf C</b>	78-45		78-45		78-45	
<b>Shelf D</b>	78-45		78-45		78-45	
<b>Shelf E</b>	78-55		78-55		78-55	
<b>Shelf F</b>	65-20	65-20	65-30	65-30	65-40	65-40

The temperature throughout the container is variable between 3 °C and room temperature

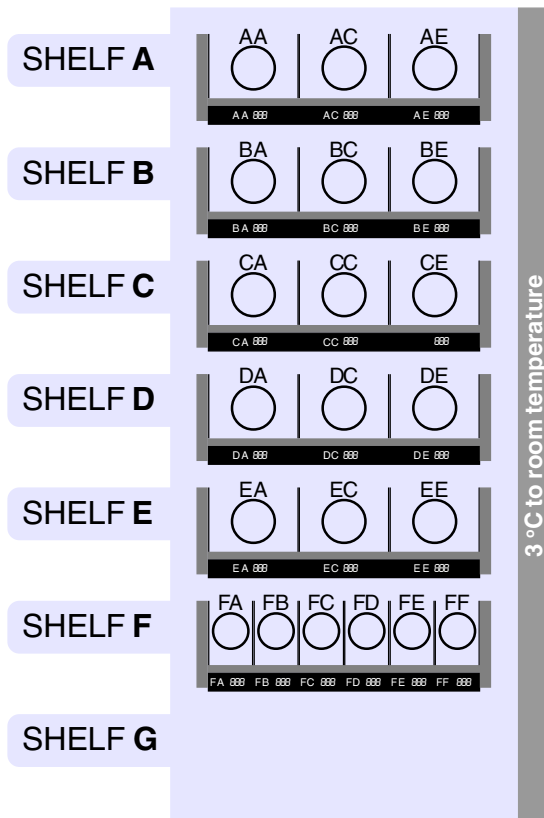



**PALMA H-70 / 18 Selections / 5 Shelves / 1 Temperature**

<b>Shelf A</b>	78-35		78-35		78-35	
<b>Shelf B</b>	78-35		78-35		78-35	
<b>Shelf C</b>	78-45		78-45		78-45	
<b>Shelf D</b>	78-55		78-55		78-55	
<b>Shelf E</b>	65-20	65-20	65-30	65-30	65-40	65-40

The temperature throughout the container is variable between 3 °C and room temperature

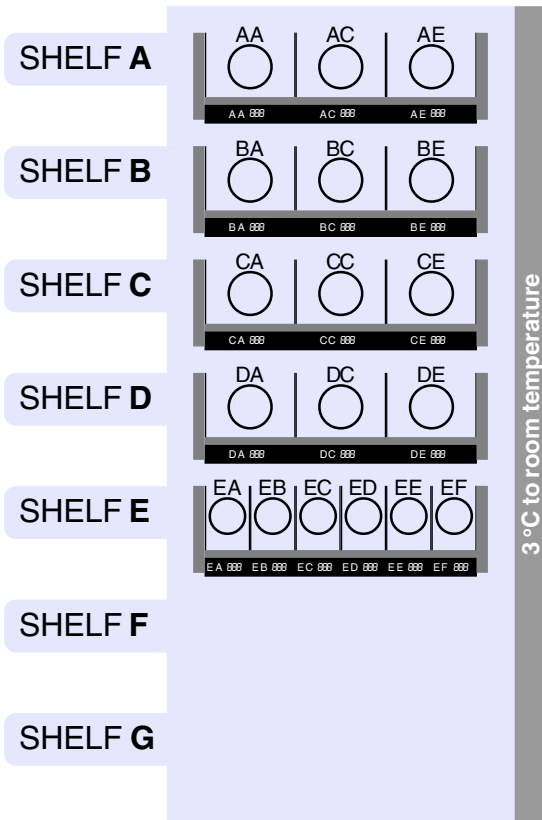

**PALMA H-87 / 36 Selections / 7 Shelves / 2 Temperatures**

<b>Shelf A</b>	65-20 D	65-20 D	65-20	65-25	65-25	65-30	65-30	65-30
<b>Shelf B</b>	65-20 D	65-20 D	65-20	65-25	65-25	65-30	65-30	65-30
<b>Shelf C</b>	78-35		78-35		78-35		78-35	
<b>TEMPERATURE SEPARATION PARTITION</b>								
<b>Shelf D</b>	78-35		78-35		78-35		78-45	
<b>Shelf E</b>	78-45		78-45		78-45		78-45	
<b>Shelf F</b>	65-50 C		65-50 C		78-55		78-55	
<b>Shelf G</b>	78-55		78-55		78-65		78-65	

The temperature in the upper section of the product container (shelves A, B, and C) is variable between 12 °C and room temperature while the lower section (D, E, F and G) is variable between 3 °C and room temperature.

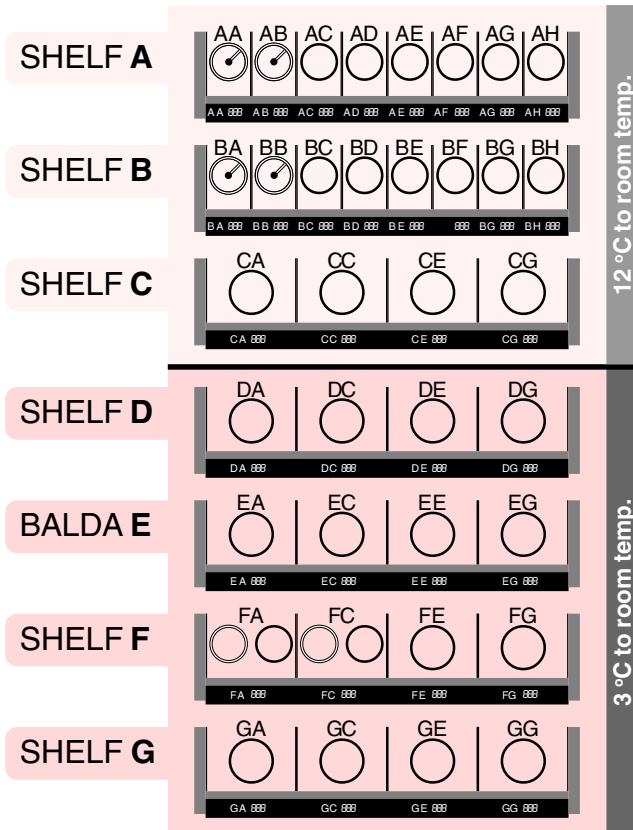



**PALMA H-87 / 28 Selections / 6 Shelves / 2 Temperatures**

<b>Shelf A</b>	65-20 D	65-20 D	65-20	65-25	65-25	65-30	65-30	65-30
<b>Shelf B</b>	78-35		78-35		78-35		78-35	
<b>Shelf C</b>	78-35		78-35		78-35		78-45	
<b>TEMPERATURE SEPARATION PARTITION</b>								
<b>Shelf D</b>	78-45		78-45		78-45		78-45	
<b>Shelf E</b>	65-50 C		65-50 C		78-55		78-55	
<b>Shelf F</b>	78-55		78-55		78-65		78-65	

The temperature in the upper section of the product container (shelves A, B, and C) is variable between 12 °C and room temperature while the lower section (D, E, F and G) is variable between 3 °C and room temperature.

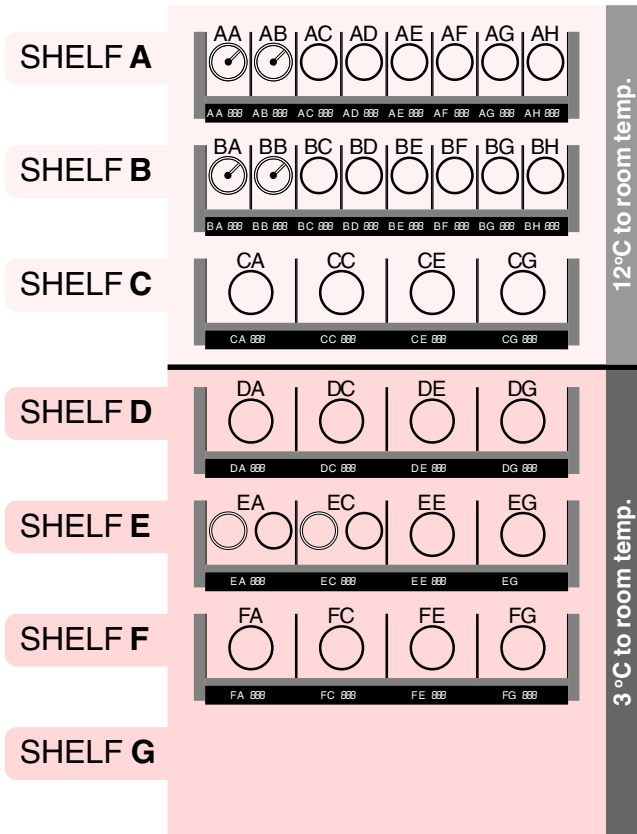

**PALMA H-70 / 21 Selections / 6 Shelves / 2 Temperatures**

<b>Shelf A</b>	65-20	65-20	65-30	65-30	65-40	65-40
<b>Shelf B</b>	78-35		78-35		78-35	
<b>Shelf C</b>	78-35		78-35		78-35	
<b>TEMPERATURE SEPARATION PARTITION</b>						
<b>Shelf D</b>	78-45		78-45		78-45	
<b>Shelf E</b>	78-45		78-45		78-45	
<b>Shelf F</b>	78-55		78-55		78-55	

The temperature in the upper section of the product container (shelves A, B, and C) is variable between 12 °C and room temperature while the lower section (D, E, F and G) is variable between 3 °C and room temperature.

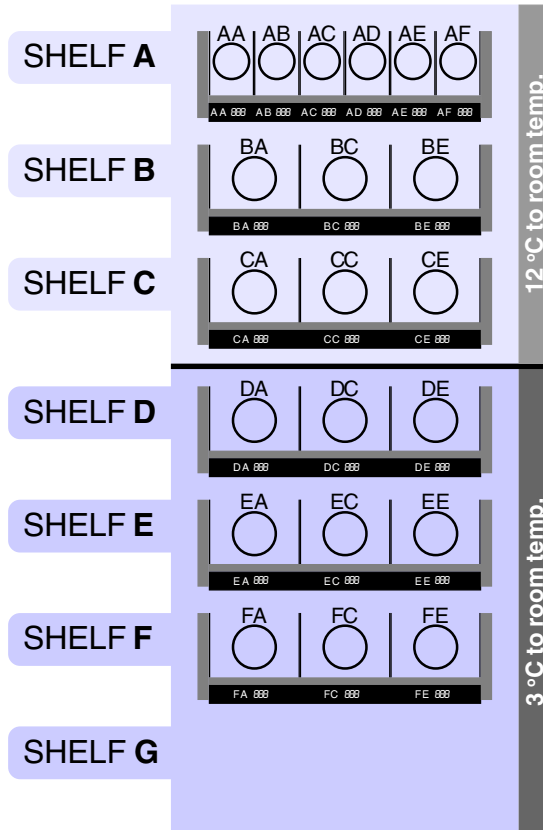



## 1.6 Exterior Communication

The door contains a LCD-type alphanumerical display card with 2x16 digits permitting visual communication between the user and the machine.

During stand-by this screen shows the time, temperature, publicity message and the credit introduced, and the selections made. When programming is initialised malfunctions are first shown, followed by the different programming functions.

Also found on the display card is a beeper whose function is to emit a beep each time a button is pushed as well as four LED diodes that illuminate the "EXACT CHANGE" and "SOLD OUT" lettering when necessary.



Figure 10

## 1.7 Instructions Lettering and Operator Data

There is a display containing the instructions for performing a service as well as space for entering the operator data.

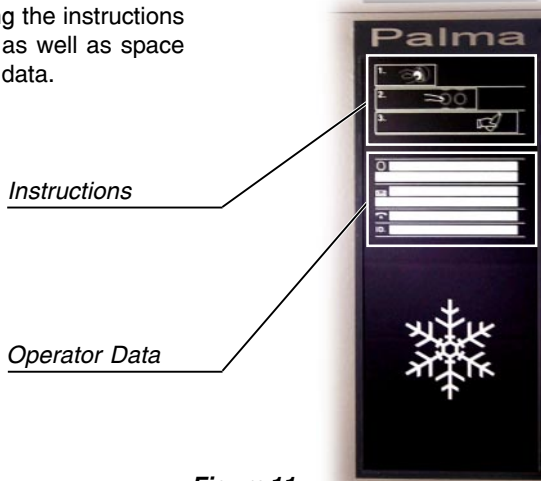

**Figure 11**

## 1.8 Operation Control

The machine is electronically controlled by a control card with a microprocessor. This card controls all machine operation as well as communication with the coin mechanism and other peripherals which may be connected.

## 1.9 Selection Buttons

These consist in an anti-vandalism keyboard constructed of stainless steel with laser-engraved letters. Selection is made by combining two letters, thus selecting the coil containing the desired product. The number of available products is limited only by the number of coils incorporated in each machine.

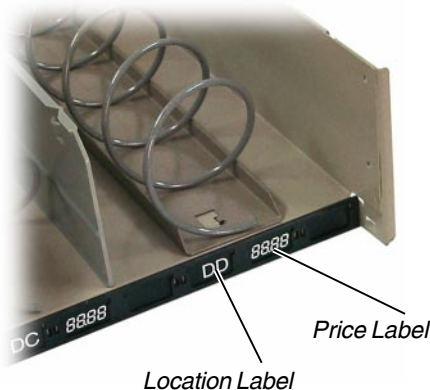

**Figure 12**

*Selection Key*



# 1.10 Coin Mechanism

This consists in an **Azkojen** coin mechanism of either **EJECUTIVO** or **MDB/ICP** types or one of another manufacturer as long as it conforms with *European Directive EMC 89/336/EEC and its modifications.*

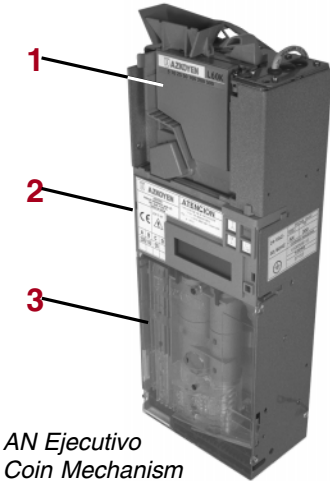

AN Ejecutivo  
Coin Mechanism

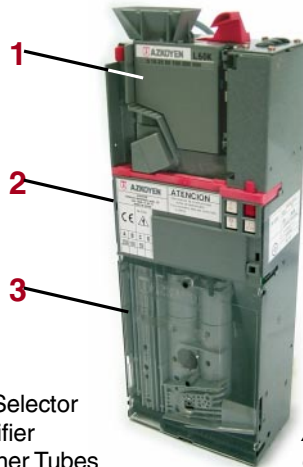

AN MDB  
Coin Mechanism

Figure 13

- 1 Coin Selector
- 2 Classifier
- 3 Returner Tubes

# 1.11 Sales Prices

A different price can be programmed for each product selection.

The maximum programmable sales price depends upon the coin mechanism used.

With the **EJECUTIVO** the maximum sales price is 250 times the base coin, e.g., if the base coin used is that of Pts.5 the maximum sales price is  $250 \times 5 =$  **Pts. 1.250** , although by working with prices in the coin mechanism in the **“Price Holding”** mode, 30 different prices can be programmed up to a maximum of Pts. 9.995 each.

When a **MDB/ICP** coin mechanism is used, the maximum sales price allowed by the machine is Pts **9.995** .



# 1.12 Coin Acceptance

Coins are accepted by a selector incorporated into the coin mechanism that admits coin of current legal tender.

The maximum amount programmable in a machine with either **MDB/ICP** or **EJECUTIVO** type coin mechanisms is Pts. 9.995.

Credit is shown in an alphanumeric display as it is introduced.



Figure 14

## 1.13 Coin Return

Coins are returned by the corresponding coin mechanism. **AN-200** or **AN-300** coin mechanisms have **three independent returners**, one for each coin unit returned. **AN-400** series coin mechanisms possess **four independent coin returners**.

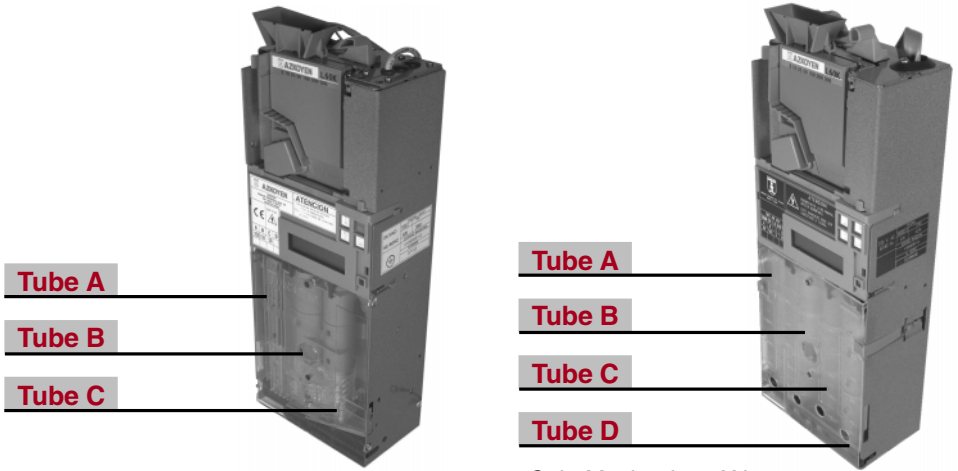

Coin Mechanism AN-200 / AN-300

Coin Mechanism AN-400

Figure 15

The coin denominations used as change are: A,B andC. The usual configuration of coin denominations in **AN-200** and **AN-300** is:

TUBE A	TUBE B	TUBE C
B	C	A

The usual configuration of coin denominations in **AN-400** series is:

TUBE A	TUBE B	TUBE C	TUBE D
B	C	A	B

Coin capacity in each tube is the following:

A	B	C
80 coins	68 coins	47 coins

The diameter of the coins that can be returned by each returner tube is determined by the tube's diameter. The measurements of the coins to be returned should be comprehended between the following:

TUBE	∅ min. - ∅ max. (mm)
<b>A</b>	17 a 26
<b>B</b>	20,3 a 30,2
<b>C</b>	17 a 23,2
<b>D</b>	25 a 32,5



## 2.- Technical Characteristics

### 2.1 Standards

The PALMA "H" line has been designed according to European standards as accredited by the "EC" on the specifications plaque. These specifications are the following:

- ✓ EN 60335.
- ✓ EC Machine Directive DSM 89/392/EEC and all its modifications.
- ✓ EC Low Voltage Directive CE DBT 73/23/EEC and all its modifications.
- ✓ EC Electromagnetic Compatibility Directive EMC 89/339/EEC and all of its modifications.

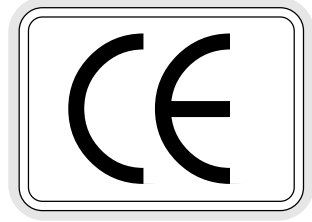

### 2.2 Physical Characteristics

MODEL	HEIGHT (mm)	WIDTH (mm)	DEPTH (mm)	WEIGHT (Kg)
PALMA H-70	1.830	723	860	238
PALMA H-87	1.830	888	875	272

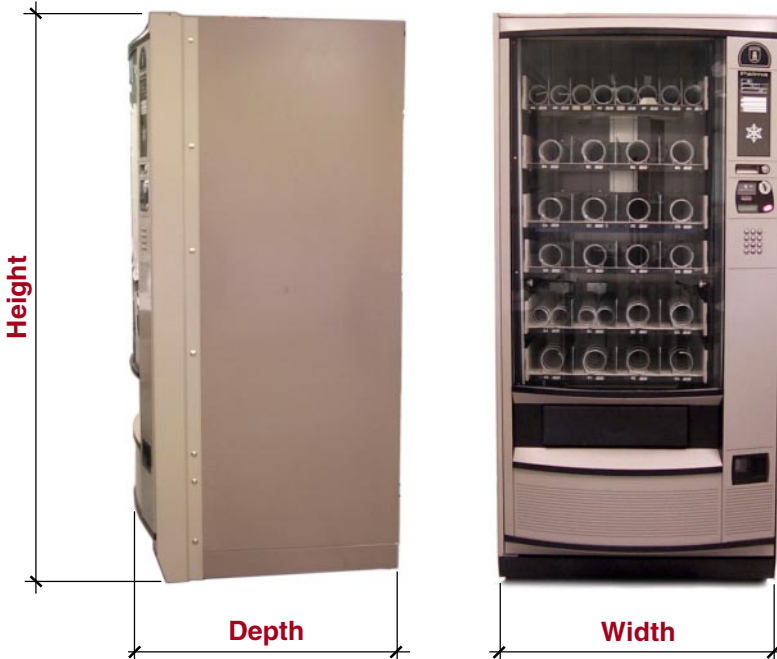
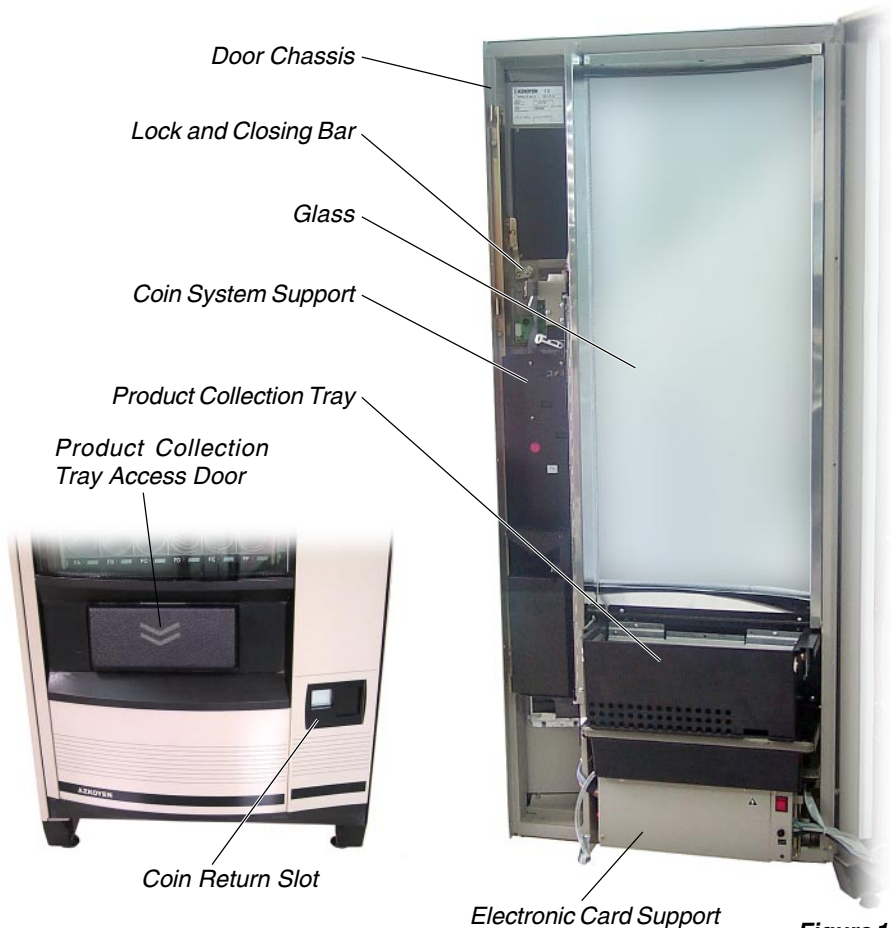

Figure16

## 2.3 Materials and Paints

### 2.3.1 Door

- ✓ The plating meets: EN 10-142 Fe P02 G Z275 Ma
- ✓ It is manufactured in 1.2mm F-111 steel plate, galvanised and painted.
- ✓ The structure is injected with polyurethane to improve insulation and afford it greater consistency.
- ✓ Polycarbonate plastics, very resistant under adverse conditions, are used.
- ✓ The product collection access door is made of ABS plastic which is highly resistant to impact.



**Figure 17**

### 2.3.2 Glass

- ✓ It is tempered and curved with a double insulation chamber.
- ✓ It consists of three 4mm glass plates. Between them are two airtight chambers for improved insulation so that with an exterior temperature of 32 °C and a relative humidity of 85%, an interior temperature of 3 °C can be reached without condensation.

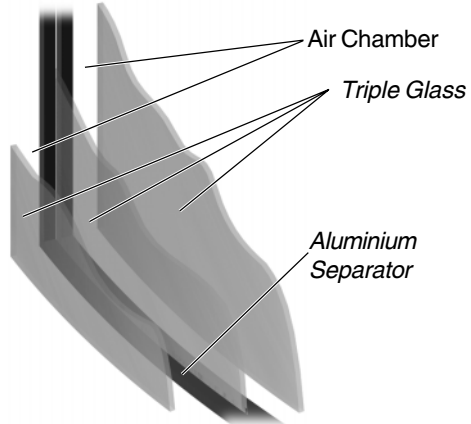

Figure 18

### 2.3.3 Body

- ✓ The plating meets Standard EN 10-142 Fe P02 G Z275 Ma
- ✓ It is manufactured in 0.8mm F-111 steel plate, galvanised and painted.
- ✓ The structure is injected with polyurethane to improve insulation and afford greater consistency.

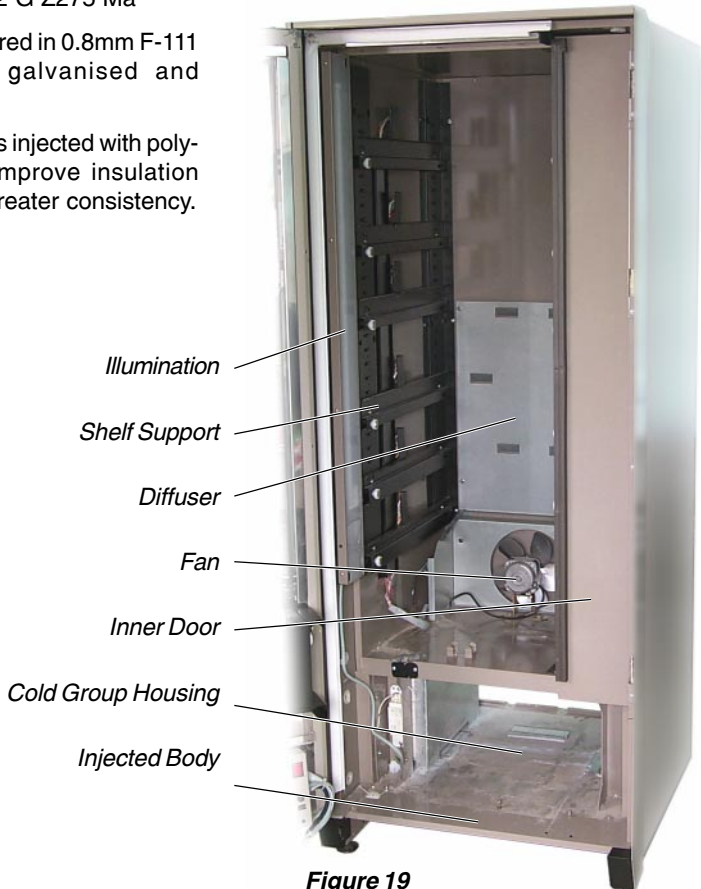

Figure 19

### 2.3.4 Paint

The painting process consists of various phases:

**Phase 1** --- Cleaning and degreasing with de-ionised water and specific degreasing detergents.

**Phase 2** --- Phosphating (addition of phosphates) to avoid rusting and act as a primer base.

**Phase 3** --- Priming with coat of zinc to protect against saline vapours.

**Phase 4** --- Hot air drying.

**Phase 5** --- Application of glossy brown polyester powdered paint that is **unleaded** (which does not harm the environment). The reference of the paint used is:

\* On **JX057 L** door

\* On **JX058 L** bodies

**Phase 6** --- Polymerisation of the paint in a kiln at 190 °C.

### 2.3.5 Saline Vapour

The resistance of the paint to saline environments surpasses 480 hours as indicated by the Standard DIN 50021/DIN 53167, the same standard surpassed by the paint on the bodies of VOLKSWAGEN cars.

## 2.4 Electrical specifications

The input voltage of this machine is 230 V.

AC and the voltage variation that permits its correct operation is 10% below nominal voltage and 6% above nominal voltage.

The functioning frequency is 50 c/s.

Power consumption is 500 W.



Figure 20



## 2.5 Temperate and Relative Humidity

In order to expect optimum performance from the machines, there environment must meet the following conditions:

- ✓ Room temperature : Between 0 °C and 32 °C.
- ✓ Relative humidity : Between 35% and 95%.

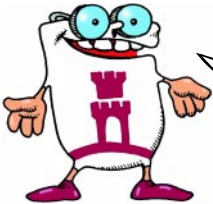
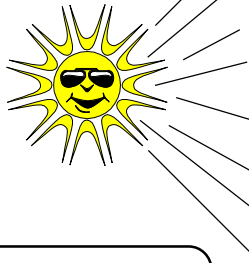

These figures are not valid if the machine is exposed to direct sunlight.



Figure 21

## 2.6 Operational Incline

Both frontal and lateral inclination should not surpass 2°. This requirement is fundamental for the correct functioning of the coin system.

## 2.7 Sound Level

The sound level of these machine never reaches 70 dB(A).



Figure 22

# 3.- Machine Description

These machines are completely constructed of independent modules which are easily dis-mounted.

## 3.1 Door Unit



Figure 23



### 3.2 Body Unit

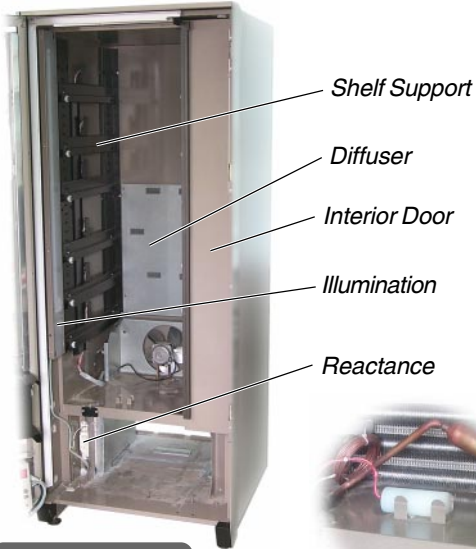

**Body Subunit + Illumination**



**Thermometric Sensor**



**BODY UNIT**

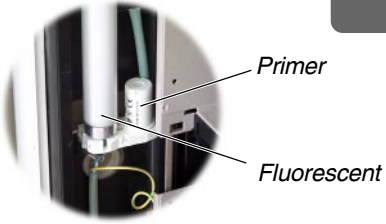

**Illumination**

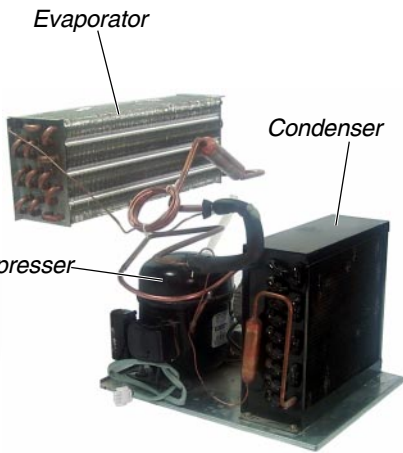

**Cold Group Unit**

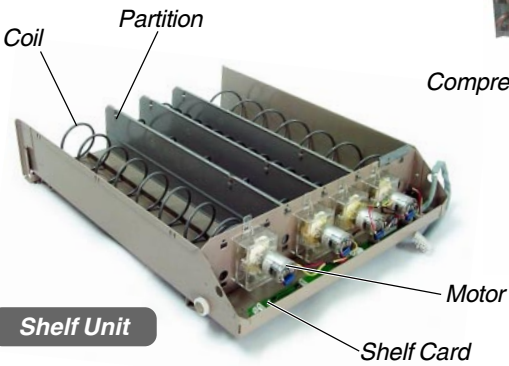

**Shelf Unit**

**Figure 24**

## 4.- Installation and Start Up

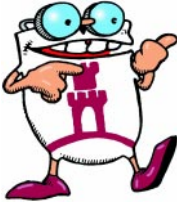

It is not advisable to install the machine in a location exposed to direct sunlight!

### 4.1 Electrical Installation

The electrical installation should meet the following conditions:

- ✓ The plug base should be a **European** type with a grounding pin and protected by a magnetothermic switch.
- ✓ Nominal outlet voltage should be 230 Vac + 6% or – 10%
- ✓ Input should be 2.400 W.
- ✓ The installation should be protected by a differential with a maximum derivation current of 30 mA.
- ✓ As a measure of security for the user and in order to avoid electrical interference, the unit should be well grounded.

### 4.2 Levelling

Once the machine has been placed in its definitive location, it must be levelled for which four adjustable feet are provided. The maximum level variation is 2°.



Figure 25

### 4.3 Ventilation

The liquation of the refrigerant gas is achieved by air in forced circulation. Air entering the machine should not proceed from a heated source and the ends of the supports should be placed so that the machine is separated from the wall to permit correct ventilation.

Wall separation bands

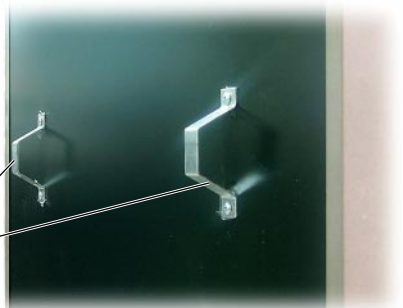

Figure 26



## 4.4 Coil Substitution

Although the **Palma H-70** and **Palma H-87** machines possess optimum configuration for vending any product, it is possible that you may wish to sell some special product or increase the number of selections of a certain product needing a special extractor mechanism.

Below the different modifications possible in the machine are explained in detail.

### 4.4.1 Changing Coils

Remove the tray as for loading, raise the coil to be substituted until it is freed from the guide where it is fastened and pull.

Next place the new coil by inserting it into the turning axis of the motor. The opening of the coil support which serves as a housing for the axis is star-shaped so that it can be regulated at intervals of 45°. Make sure the new coil is firmly fitted into the guide.

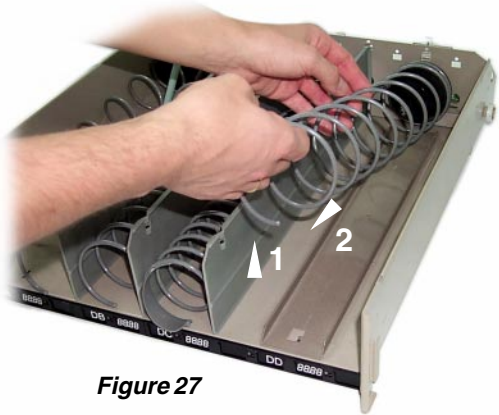

Figure 27

### 4.4.2 Installing a Contrary Coil Together with a Standard One

This option is especially appropriate for extracting large products or those needing to be stored vertically and requires special installation.

The turning action of the motor is directly transmitted to the standard coil which, in turn, using two gears turns the contrary coil in the same direction.

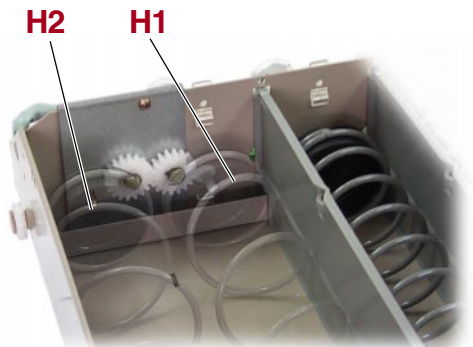

Figure 28

Care must be taken to insure that the pins fit into the crown of the coil support.

To correctly perform this installation, first coil **H1** must be installed followed by **H2**.

Keep in mind that the position of the end of the coils must not impede the fall of the product and must be placed as shown in **figure 29**.

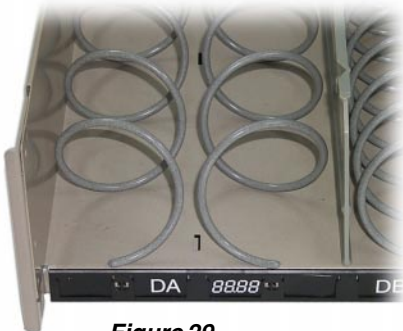
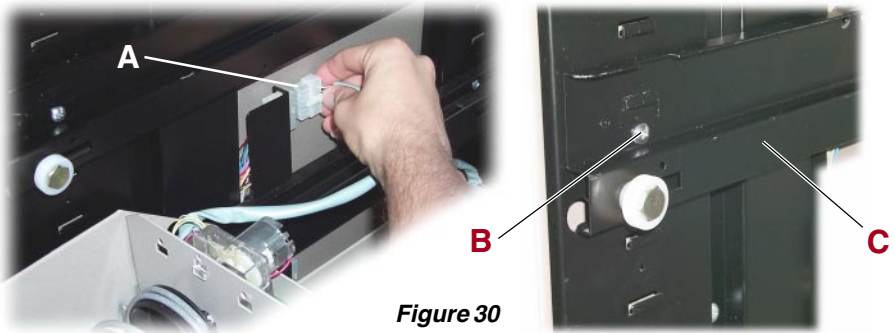

Figure 29

## 4.5 Regulating Tray Height

If you wish to vend products that do not fit into the space between trays because of their height, the trays may be moved in increments of 32mm in the following manner.

1. Shut down the machine.
2. Disconnect the connection cable (A) from the tray.
3. Remove the shelf by lifting it gently.
4. Remove the screws (B) holding the bracket (C).
5. Place the bracket in the new supports and rescrew.
6. Repeat the operation with the other bracket.
7. Replace the tray and reconnect it.

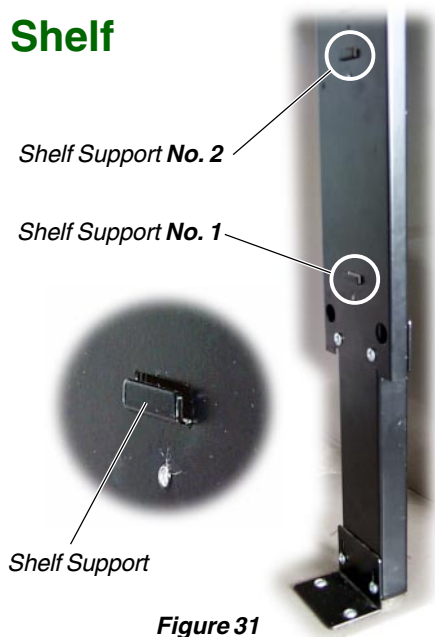

**Figure 30**

## 4.6 Installing the Seventh Shelf

If a seventh shelf installation is desired, all its positions must be fixed. To do so, place the brackets in the supports as indicated in the following table.

SHELF SUPPORT #	SHELF
27	<b>A</b>
22	<b>B</b>
17	<b>C</b>
12	<b>D</b>
7	<b>E</b>
2	<b>F</b>
1	<b>G</b>



**Figure 31**

## 4.7 Changing Spacing between Coils

If, due to the characteristics of the product to be vended or in order to change the size of a coil it should be necessary to increase or decrease the space reserved for each extractor, it suffices to remove the corresponding separator (**S**) and place it in the appropriate grooves (**R**) of the trav.

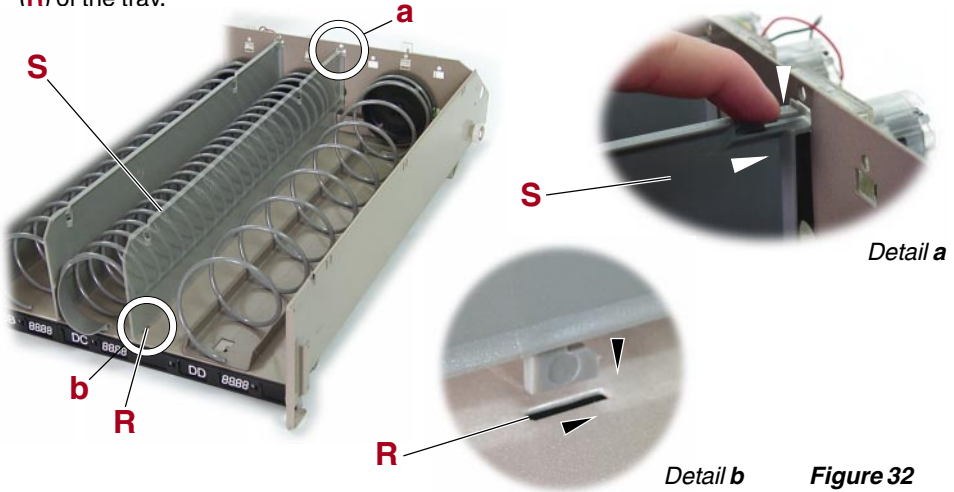

Figure 32

## 4.8 Loading Products

1. Lift the shelf lightly and pull. It will remain bent downward. Shelves A, B, C, D and E are hinged. Shelves F and G are not.



Pull upward...



... and outward.

Figure 33

2. The product is loaded by placing it between the spirals of the coil in such a way that it sits loosely and is not pressed upon by the spirals. It is recommended that the product rest against the forward spiral, leaning against the one behind so that it falls more easily. Care should be taken so that the product is sufficiently secure in the spiral and cannot be

freed even when the machine is struck. If the entire coil is not to be loaded it is recommended that it be loaded from the outside towards the inside.

- The coils can be turned every 45° to improve product extraction although the most common operating position is "6 o'clock" and for boxed products "12 o'clock" (fig. 36). If a product should not be completely extracted by the coil, there are "expellers" located at the end of the coil which push the product until it falls (fig. 35).



Example of a Load

**Figure 34**

### 4.8.1 Recommendations for Loading Products

- ✓ *If products that are packaged in bags or boxes are not placed correctly they may cause problems. Make sure that the closures of bags and boxes do not become caught beneath the spirals.*
- ✓ *It is recommendable that products that can be damaged be located on the lower trays.*
- ✓ *To maintain the stability of the machine several trays should not be removed at the same time.*



Product Expeller

**Figure 35**

### 4.8.2 Loading Tests

Motors with coils loaded with products have passed the following tests:

<b>Ø78 Coil</b>	2 Kg.
<b>Ø65 Coil</b>	1,5 Kg.
<b>Double coil</b>	1,5 Kg
<b>Contry coil + standard</b>	2 Kg.



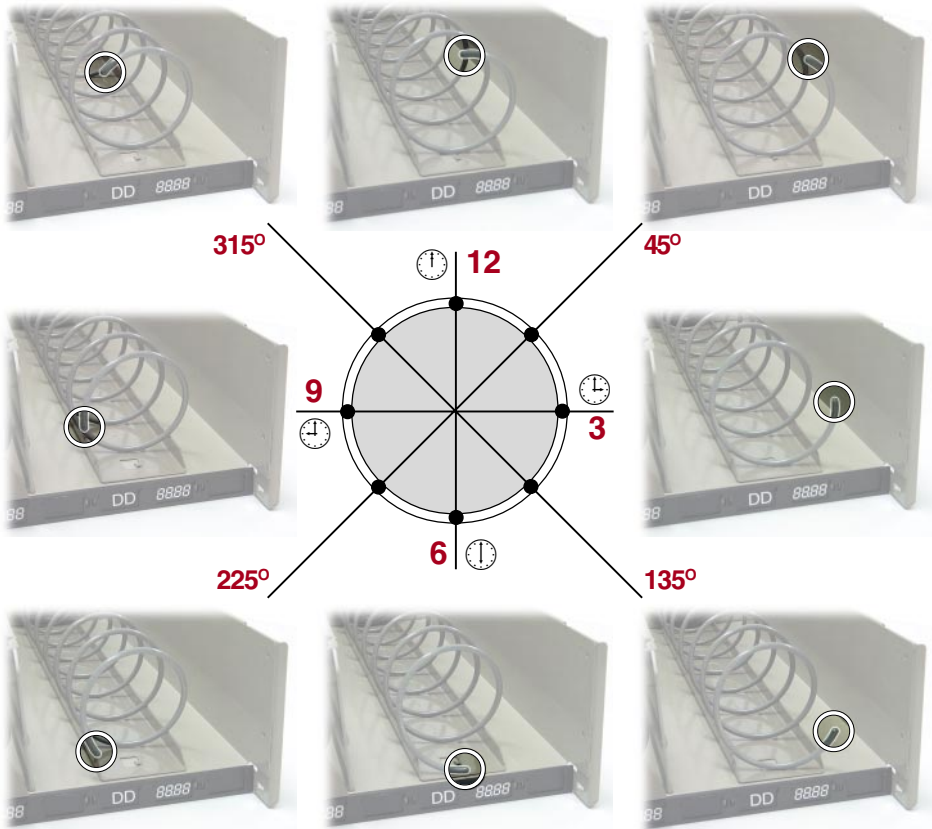

Positions of the Coil

Figure 36

## 4.9 Identification of Products and Price

Each selection is identified by a label below each coil with a combination of two letters. The first letter refers to the position occupied by the shelf and the second the position of the coil within the shelf. There is also an numerical label below each coil to indicate the price which should be made with a permanent marker. Changing the price and product labels is done by carefully lifting the label support with a screwdriver and pushing the label upwards.

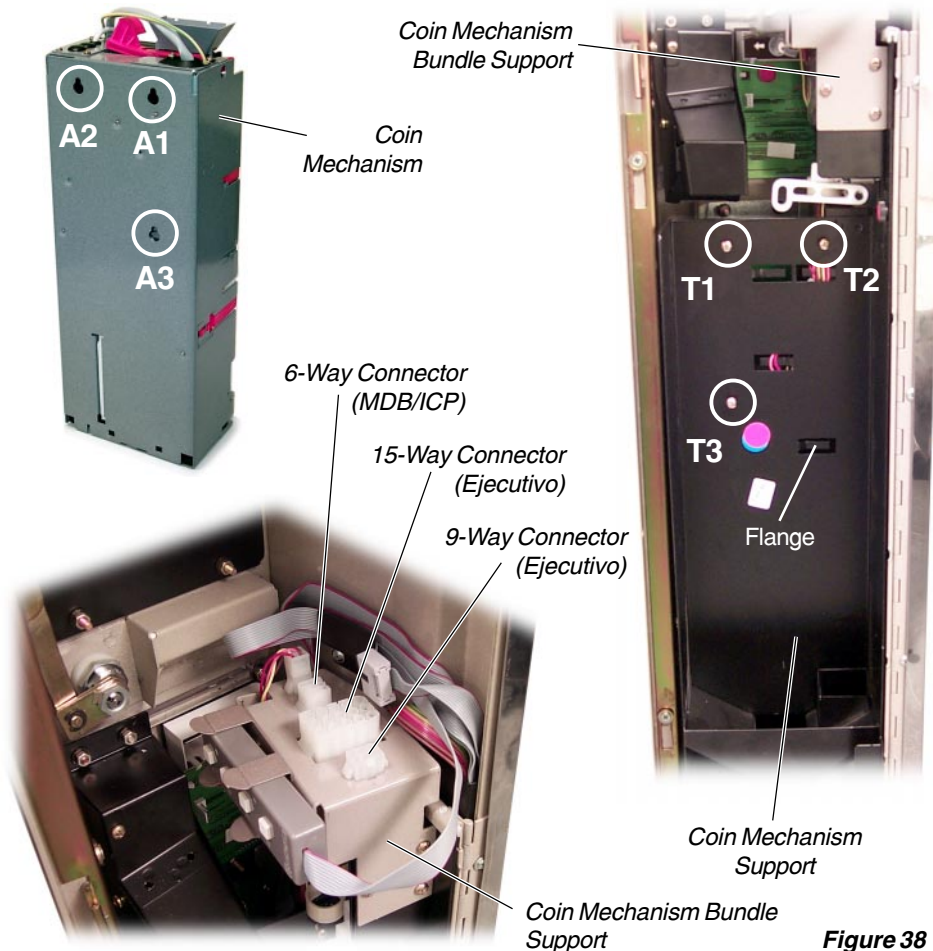

Figure 37

## 4.10 Installation of the Coin Mechanism

To install an **Azkoyen** coin mechanism type **MDB/ICP** or **EJECUTIVO** the following steps must be followed:

- 1.- Turn the machine off.
- 2.- On the coin mechanism support there are three screws (T1, T2 and T3) where three slots are located on the back of the mechanism housing (A1, A2 y A3). The coin mechanism should be fitted into them.
- 3.- Plug the coin mechanism into its connectors found in the connector support shown in **figure 38** and screw down the grounding bundle (yellow-green) to the chassis of the door. The leftover cable can be pushed behind the coin mechanism support and fastened with special flanges for this purpose.



**Figure 38**



# 4.11 Loading the Coin Returners

This depends upon the type of coin mechanism used: **MDB/ICP** or **F.I.F.C.U.T.I.V.O**

✓ **MDB/ICP** coin mechanism:

- The programming mode must be accessed by pressing key **C** in the machine's programming box.
- Introduce the change coins.
- Exit programming by pressing **C** once more.



✓ **EJECUTIVO Azkoyen** coin mechanism:

- Press the red key of the coin mechanism to enter programming and access function **F02**.



- Introduce the change coins.
- Exit programming by pressing the **red key** again.

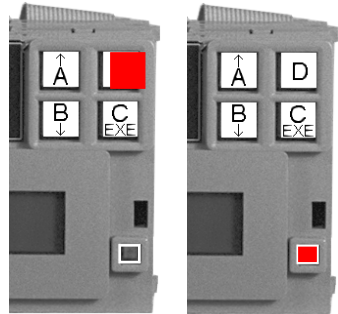

Coin Mechanism AN-300

Coin Mechanism AN-400

Figure39

# 4.12 Initial Programming

The machine leaves the factory with **all prices programmed equally**. Propulsion is also programmed **according to the type of coil**. All accounting is **set at zero** and the temperature at **5 °C**. Therefore, the first thing that must be programmed when the machine is installed for the first time is the price for each product to be sold in program function **201**, as well as the propulsion if a normal coil is substituted for a double one or vice versa, and finally the temperature (see **Module 3: Programming**).

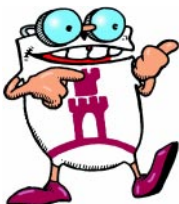

**DO NOT CONNECT THE MACHINE TO THE POWER SOURCE FOR AT LEAST 30 MINUTES AFTER THE MACHINES'S FINAL INSTALLATION. THE REFRIGERATION CIRCUIT MUST REMAIN ON STAND BY OR IT COULD BECOME DAMAGED!**

## 4.13 Start Up

Once the machine is connected to the power source activate the general switch.

Observe in the alphanumeric display that the machine performs an autocheck and then the normal messages, i.e., the time, temperature and publicity message appear.

Next the refrigeration group goes into operation.



General Switch

## 4.14 Verifications and Start Up

1. Close the door and perform a service for each selection.
2. Introduce the different coin denominations and check product extraction as well as coin return.
3. Once this test is complete make sure that the accounting data is correct and then erase the accounting data in the machine (Function 171) and in the coin mechanism. Manually empty the coin returners and erase their accounting data.



Figure 40

## 5.- Maintenance

### 5.1 Exterior Cleaning

Use warm water, between 20 °C and 40 °C and any one of the following products: Dish detergent, neutral shampoos or a glass cleaner without bioalcohol.

Rinsing should be done with a 2% vinegar solution before drying with a soft cloth or gauze.

For persistent stains (grease, beverages, etc.), use a solution of water and rubbing alcohol (1% solution of 96° ethanol).

### 5.2 Cleaning the Condenser

Dust and dirt collect in the condenser as a result of the refrigeration air that circulates through by means of the ventilator. As the condenser becomes more obstructed, the performance of the refrigeration group is reduced due to the lessening liquation of the refrigerant gas.

The condenser should be periodically cleaned with a vacuum, a non-metallic brush or with pressurised gas (air, nitrogen, CO<sub>2</sub>, etc.) as well as the back air exhaust grate.

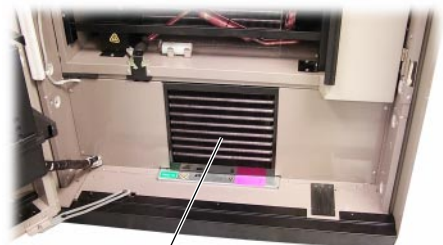

Condenser

Figure 41



# 6.- Description of a Service

**PHASE 1**  
Coin Insertion



If the "exact change" message is lit, with **MDB/ICP** coin mechanism it indicates that only exact coinage will be accepted and with **EJECUTIVO** coin mechanism, that only programmed coins will be accepted, which , in order to guarantee correct change return, should be the same coinage needed for it.



"Exact Change"

**REJECTED**

**ACCEPTED**

**PHASE 2**  
Coin analysis:  
Acceptance or rejection and  
Classification

Rejected coins are sent directly to the exterior

Change coins go to the corresponding tube unless it is full or out of order. In such cases, they will be sent to the bin.

Each coin is analysed according to the models recorded in the selector. If accepted, their amount increases the displayed credit.

Coins that are not for change are sent directly to the bin."



PHASE 3

Product selection or coin return

COIN RETURN

PRODUCT SELECTION



If selection is delayed too long after 15 minutes the credit disappears.



During the interval before selection, the credit introduced can be recovered.



If it is an "EJECUTIVO" coin mechanism, it is programmed for "Obligatory Sale" and does not allow credit recovery.

PHASE 4

Initiate sale

The machine calculates whether the credit introduced is more, less or equal to the selection price requested.



LESS

EQUAL

MORE



RETURN TO PHASE THREE

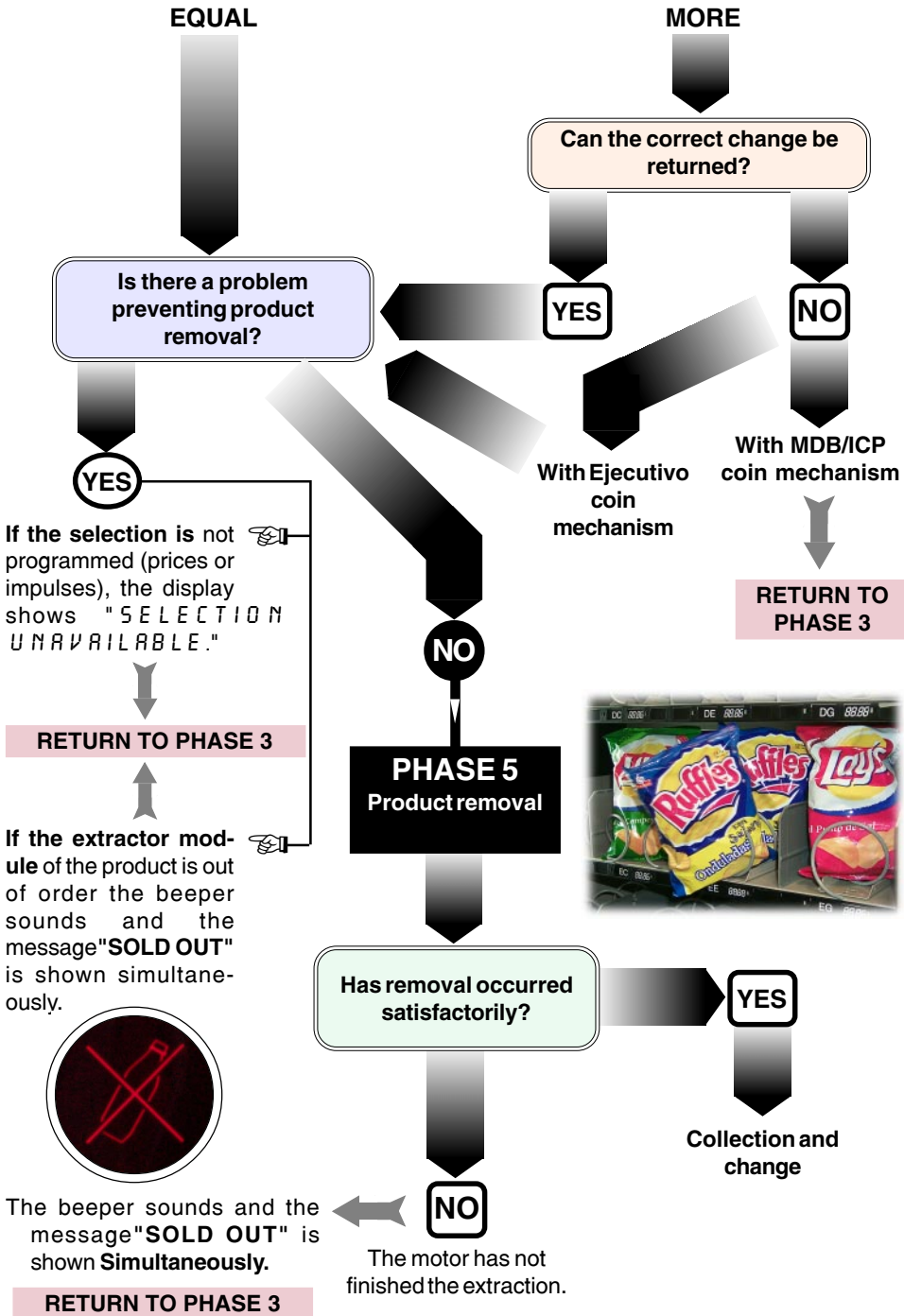



- 3.- Unscrew the two lateral flanges holding the glass on the inside. The left flange fits between the glass and the door chassis therefore it is necessary to pull on it laterally as shown in **figure 2**.
- 4.- Free the glass by pushing it from the outside while supporting it from the inside and taking care that it does not come out suddenly and fall.



Figure 3

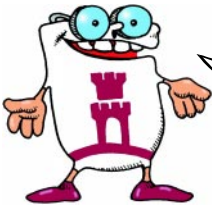

**DUE TO THE SIZE AND WEIGHT OF THE GLASS IT MAY BE SAFER FOR TWO PEOPLE TO REMOVE OR REPLACE IT.**

## 1.2 Disassembling the Product Collection Tray

- 1.- Shut down the machine.
- 2.- Remove the product collection tray by pulling it outward.
- 3.- Remove the anti-theft opening lever guide and remove the axis from its housing in the swinging door.

*Anti-theft Support*  
*Product Collection Tray*



Figure 4

*Lever Guide*  
*Anti-theft Opening Lever*



Figure 5



4.- Remove the four screws (T) from the anti-theft support and set aside.



Figura 6

5.- To disassemble the swinging door simply lift it 90° and move it toward the right (1) so that the left axis comes out of its housing. Next, move the door to the left (2) freeing it completely.

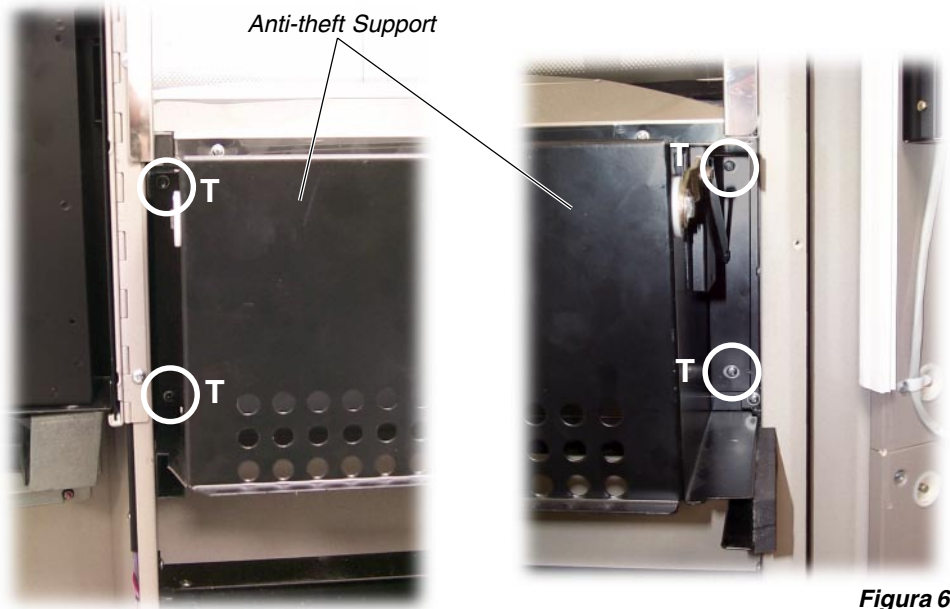
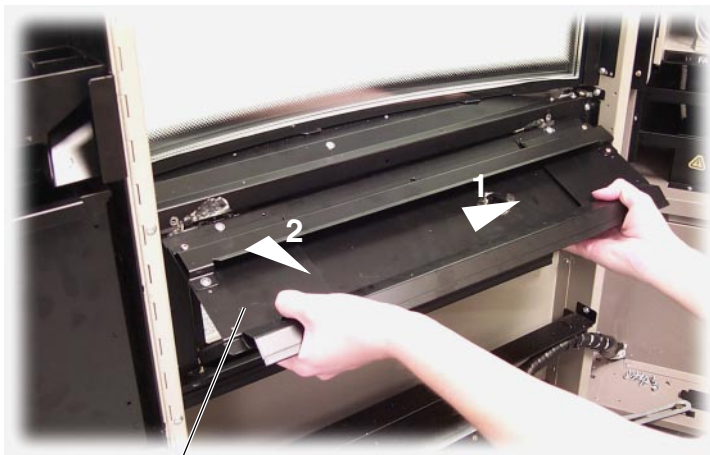

Swinging  
Door

Figure 7

## 1.3 Removing the Closure Bar

- 1.- Shut down the machine.
- 2.- Loosen the safety screw from the coin mechanism support and remove it by pulling and turning toward the right (**figure 8**) previous to removing the closure bar.



Coin Mechanism Support



Figure 8

Safety Screw

- 3.- With the help of some round-edged pliers or a flat head screw driver remove the safety washer joining the door lock to the rod of the closure bar. See **figure 9**.

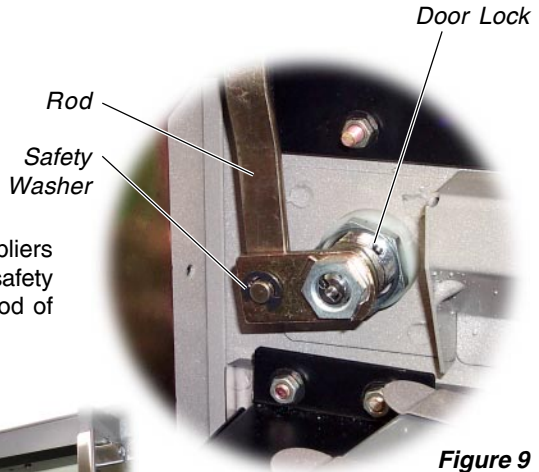

Figure 9

- 4.- Loosen the four screws of the front guides (F) of the bar (those with the rectangular grooves, **figure 10**).

- 5.- First pull the bar upward to free the lateral guide screws (L) and then outward to remove the bar from the door. See **figure 10**.

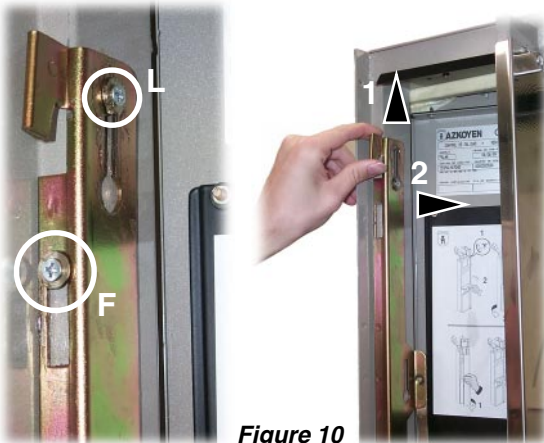
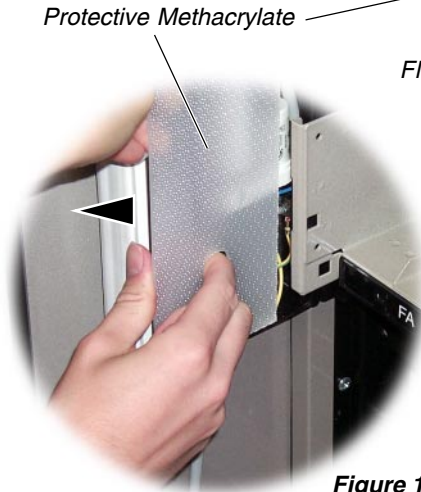

Figure 10

## 1.4 Changing the Fluorescent and the Primer

- 1.- Shut down the machine.
- 2.- To access the flourescent tube and the primer, remove the holding flange and the protective methacrylate. To do so, loosen the screws fastening both parts. See **figure 11**.



**Figure 12**

- 3.- Once the screws are loosened and the flange has been removed, extract the methacrylate by pulling it crosswise as shown in **figure 12**.

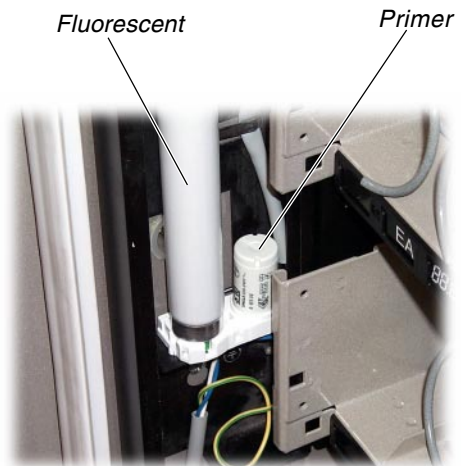

**Figure 13**

- 4.- To remove the primer, turn it and pull outward and up. See **figure 13**.
- 5.- To remove the flourescent tube, first twist it in either direction and pull it out freeing the connecting pins.
- 6.- Laterally insert the new flourescent tube and turn to fasten. To test it, the machine may be connected by activating the general switch. Once tested disconnect the machine again.
- 7.- Fit the methacrylate into the corresponding groove and screw down the flange.
- 8.- Connect the machine and close the door.

## 1.5 Disassembling a Shelf

- 1.- Shut down the machine.
- 2.- Pull out the shelf (**figure 14**) by gently lifting it and pulling. It will remain bent downward. Shelves A, B, C, D, E and G are hinged. Shelves F and G are not.



Figure 14

- 3.- Disconnect the shelf connection cable (**figure 15**). If the upper shelf impedes connector access, it may be gently lifted.

Connector



Figure 15

- 4.- Lift the disconnected shelf with both hands to free it from the stops and pull outward to free it from its guides. See **figure 16**.

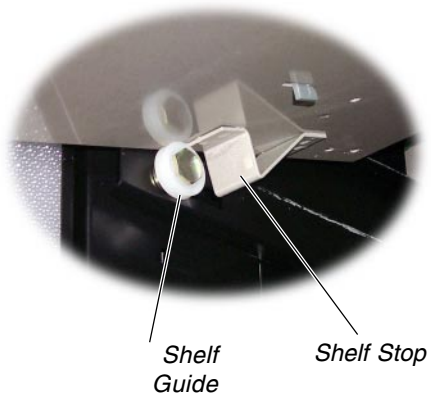

Shelf Guide

Shelf Stop

Figure 16

# 2.- Block Schematic

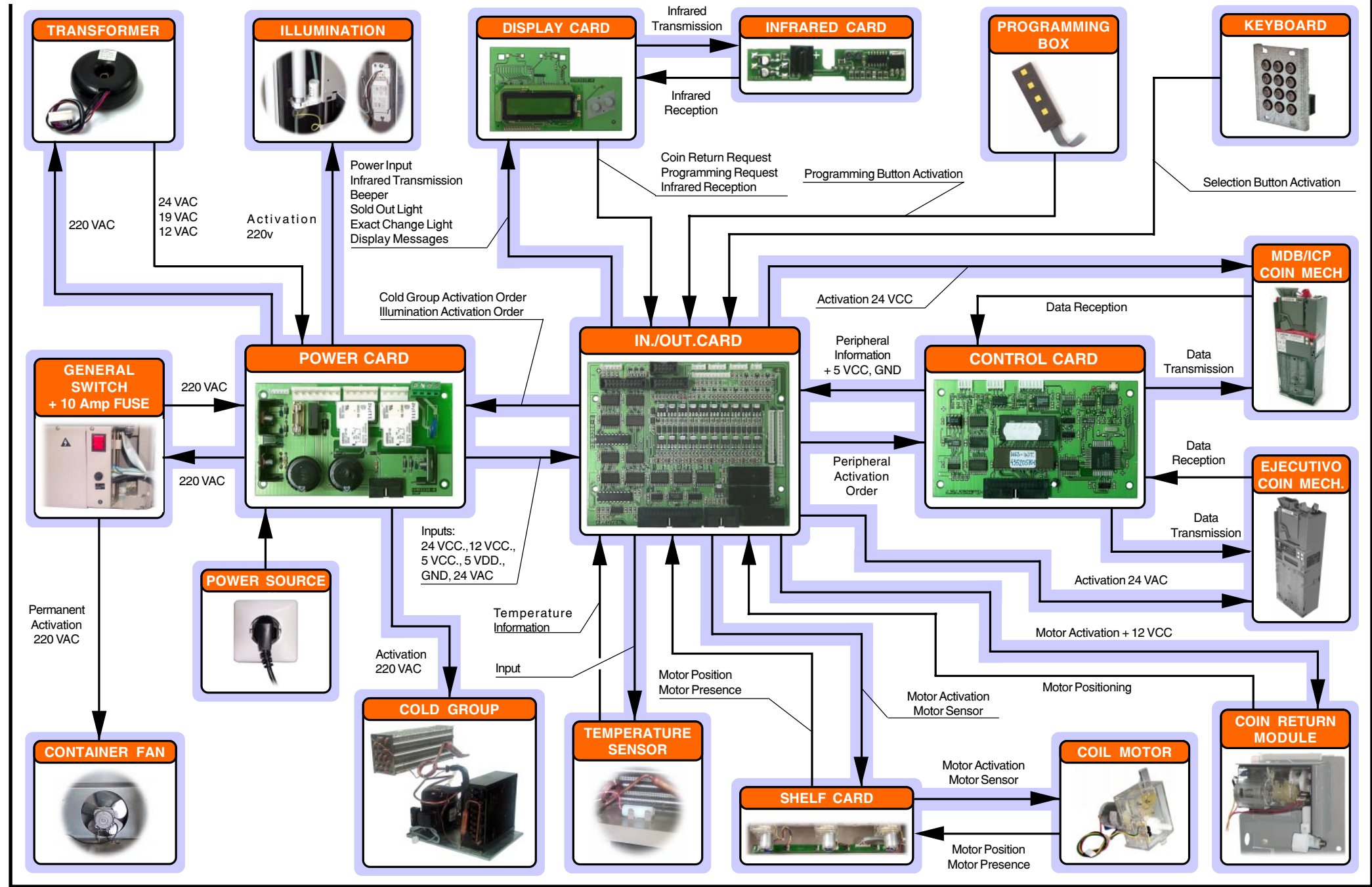



## 3.- Component Description

### 3.1 Power Input

It has a double function:

- ✓ Provide necessary voltage for the operation of the rest of the machine.
- ✓ Protect the electrical unit against any surge generated in the power source or over-consumption by the machine itself.

It consists of the following elements:

- ✓ Illuminated Bipolar Switch
- ✓ Power Source Protection Fuse
- ✓ Transformer
- ✓ Power Card

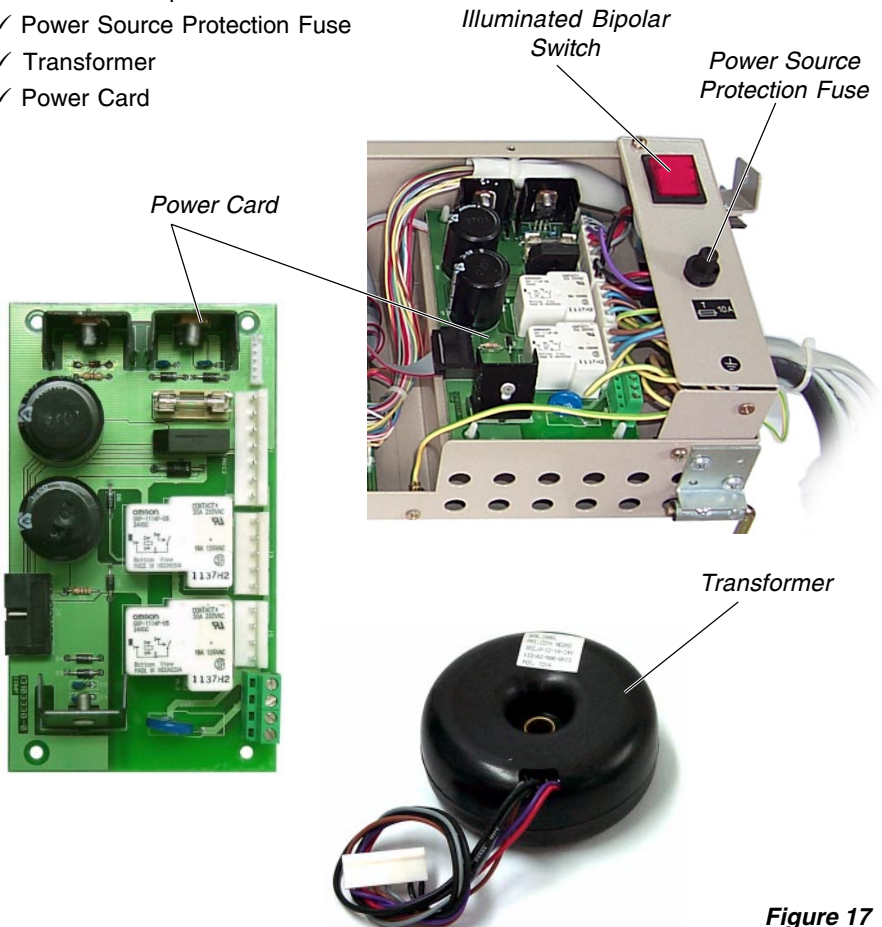

Figure 17



### 3.1.1 Illuminated Bipolar Switch and the Power Source Protection Switch

When the unit is connected to a biphasic electrical network the voltage is applied to the bipolar switch. When this switch is deactivated, the machine remains completely disconnected from the network and when it is activated the two phases become directly applied in the machine.

Between the machine and the bipolar switch a **10 amp** switch is found whose function is to protect the machine from possible short circuits which the components directly fed by the network might produce such as: the cold group, illumination, the container fan or the power source transformer.

The **container fan** is activated directly from the bipolar switch.

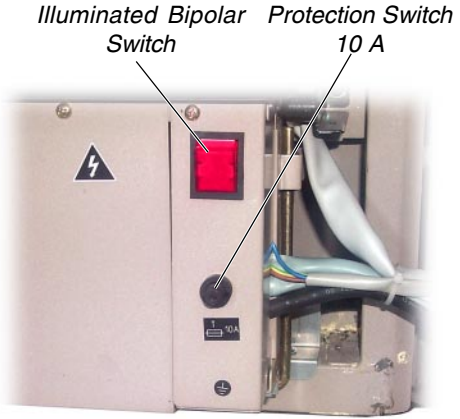

Figure 18

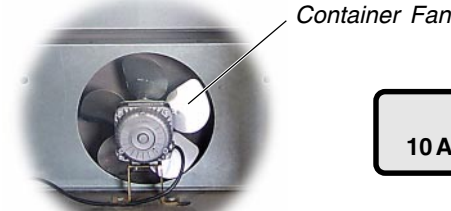
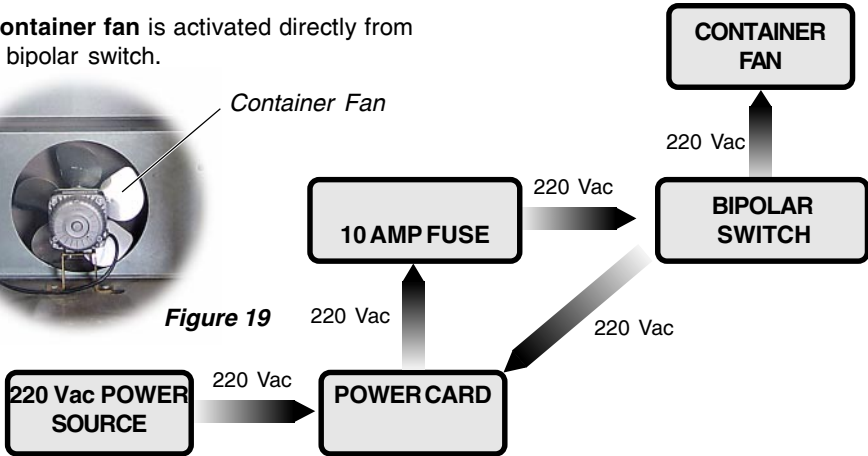

Figure 19



### 3.1.2 Transformer

Its purpose is to transform the network voltage into the different voltages needed by the rest of the machine.

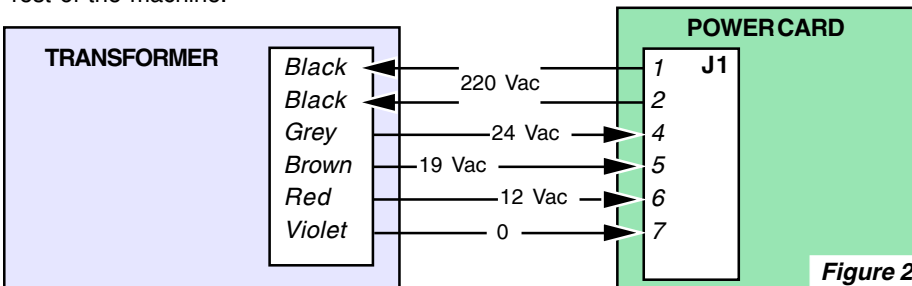

Figure 20



It is of the toroid type whose dispersion is minor which improves performance. Its output is **96 VA**.

It consists of a primary coil whose nominal voltage is 230 VAC, with a functioning margin of 207 VAC to 244 VAC. The secondary coil produces 24 VAC, 19 VAC and 12 VAC, with a maximum intensity of 4 amps.

### 3.1.3 Power Card

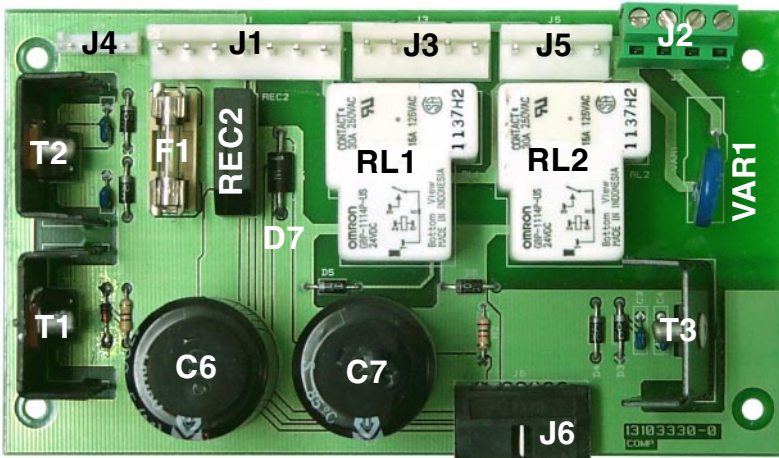

**Figure 21**

It has the following functions:

#### 1.- Protection Against Surges.

##### Operation:

It consists of a varistor which absorbs tension peaks which may be produced by the network beyond 275 v. If the voltage peaks are of long duration the varistor will short circuit and the 10 Amp fuse will blow.

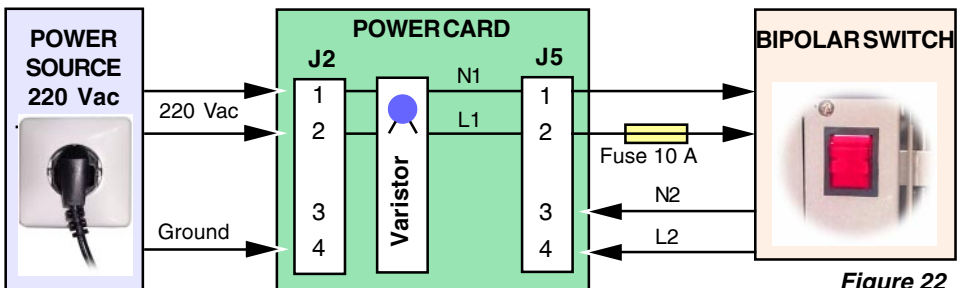

**Figure 22**



### 2.- Rectifying 12 Vac Current and Converting It into 12 Vcc, 5 Vcc and 5 VDD.

#### Operation:

The 0V. line is protected by fuse **F1 of 6.3 Amps**. In this way the transformer is protected against any short circuits which might be produced in any of the circuits it feeds.

12 Vac are fed into the entrance to the rectifying bridge **REC2** and exit it rectified and filtered by **C6 of 4700 uF**. From here it is stabilised by transistor **T1 (BDX53)** and the associated circuit. 12 Vcc exit emitter T1 which are simultaneously applied to two regulating circuits **T1 and T2 (78H05)** which convert it into 5 Vcc and 5 VDD respectively.

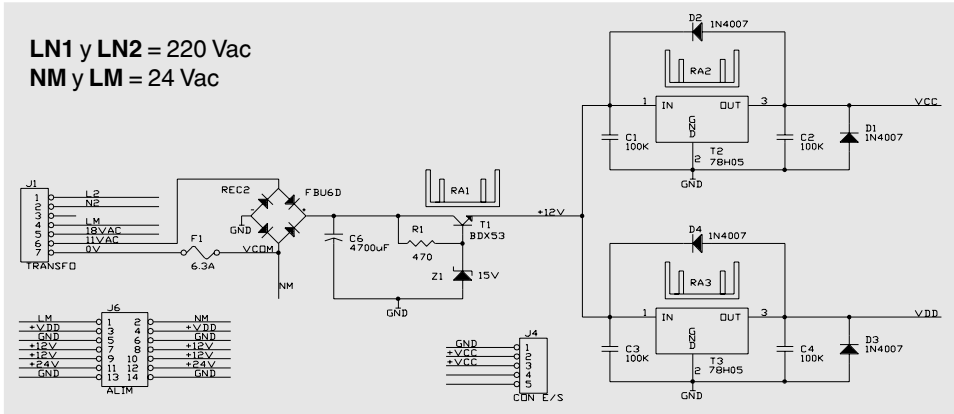

Figure 23

### 3.- Rectifying the 19 V and Converting it into 24 Vcc

#### Operation:

The 19 Vac current is rectified by the diode **D7 (1N5408)** and filtered by **C7 of 4700uF** so that 24 Vcc exit from its extremities.

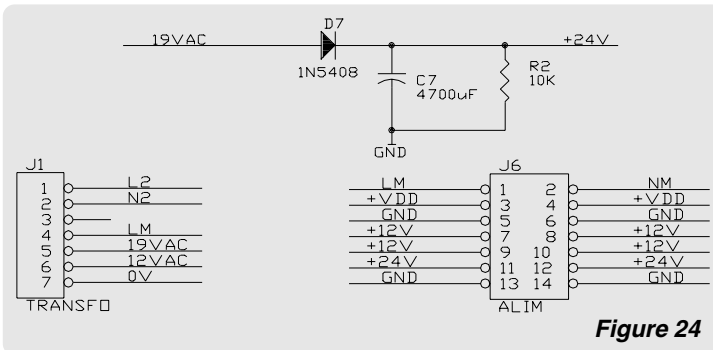
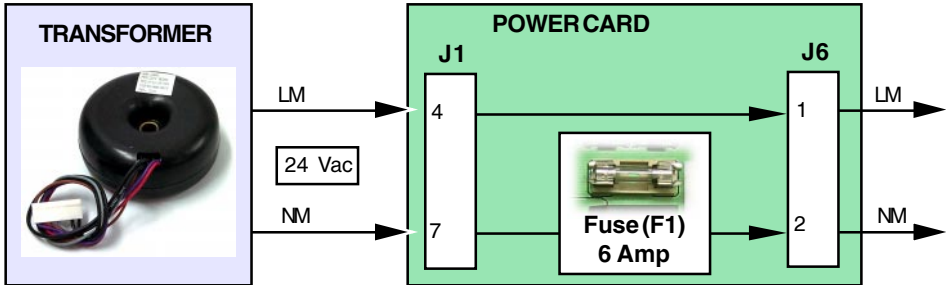

Figure 24

**4.- Card Interface in the Ejecutivo Coin Mechanism**

The 24 Vac (LM-NM) for feeding the **Ejecutivo coin mechanism** exit the transformer and proceed to connector J1. They pass through fuse F1 (6.3 Amps) and exit connector J6.

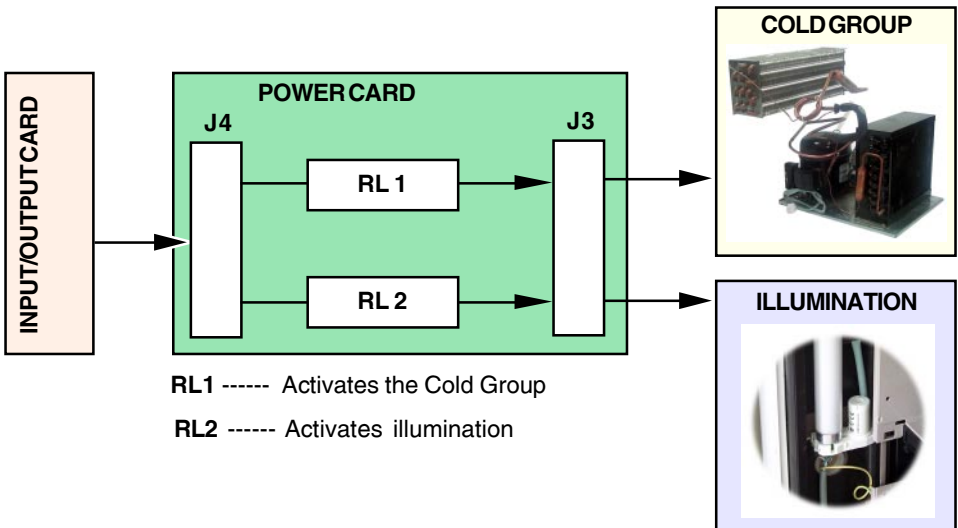

*Figure 25*

**5.- Cold Group and Illumination Activation**

The relays which activate the Cold Group and illumination are found on the power card. Connector J4 orders the activation of relays RL and RL2.

A voltage of 220 Vac exits connector J3 putting the Cold Group and illumination into operation.



*Figure 26*

### 3.2 Illumination

Its purpose is to illuminate the interior of the machine for improved exposure of the products.

It consists of a 30 W fluorescent tube, a 30 W reactance and a primer.

Illumination is controlled by software from the Control Card. The I/O Card governs the relay (RL2) found on the Power Card.

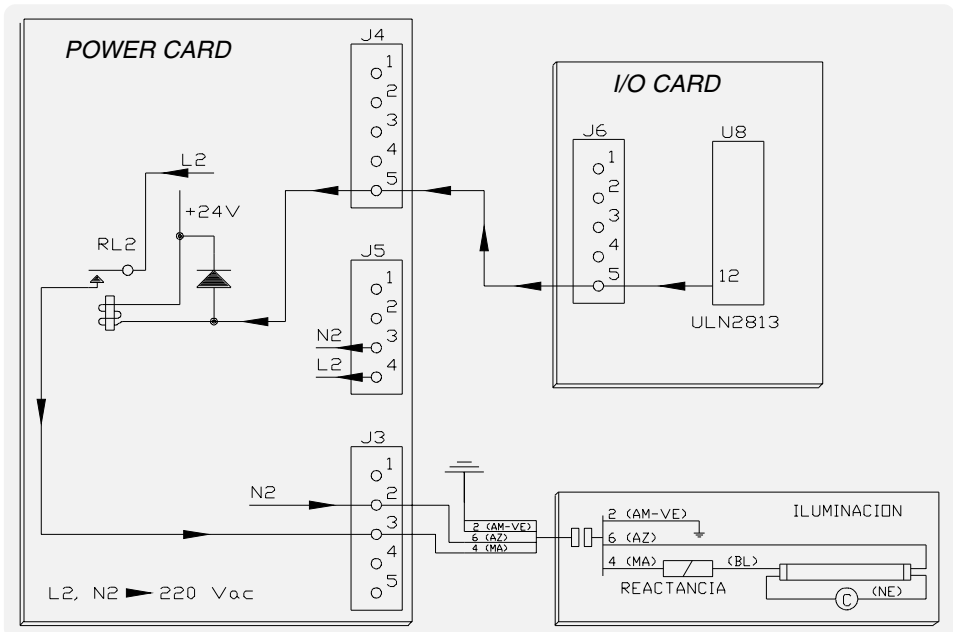
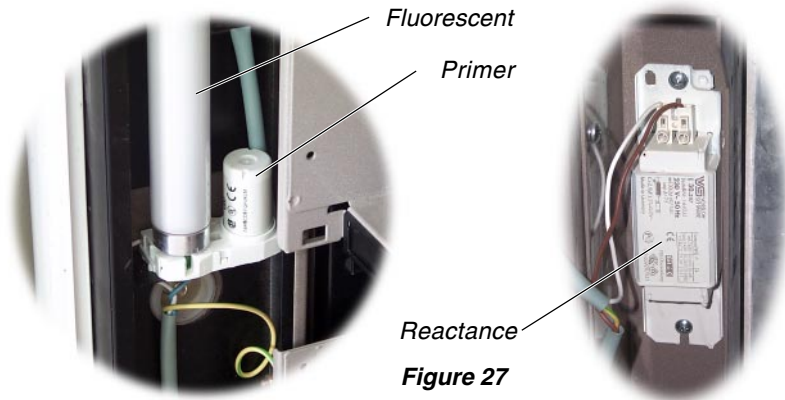

Figure 28

## 3.3 Cold Group

Its purpose is the maintain products for sale in the best possible condition without losing any of their original characteristics.

BRAND	MODEL	COMPRESSOR POWER	CYLINDERS	REFIGERANT	REFRIGERANT AMOUNT
Electrolux	GP12TB	3/8 C.V.	12 c.c.	R-134 a	260 grs.

The compressor has the following characteristics:

### 3.3.1 Electrical Operation of the Cold Group

The electrical system of the Cold Group consist of **the compressor unit + condenser fan**. Both elements function simultaneously and are governed by software from the Control Card according to the temperature programmed. To monitor container temperature at all time there is a **thermometric sensor** which functions as an electronic digital thermometer. In this way the Control card "**reads**" the thermometric sensor every 5 seconds and acts accordingly.

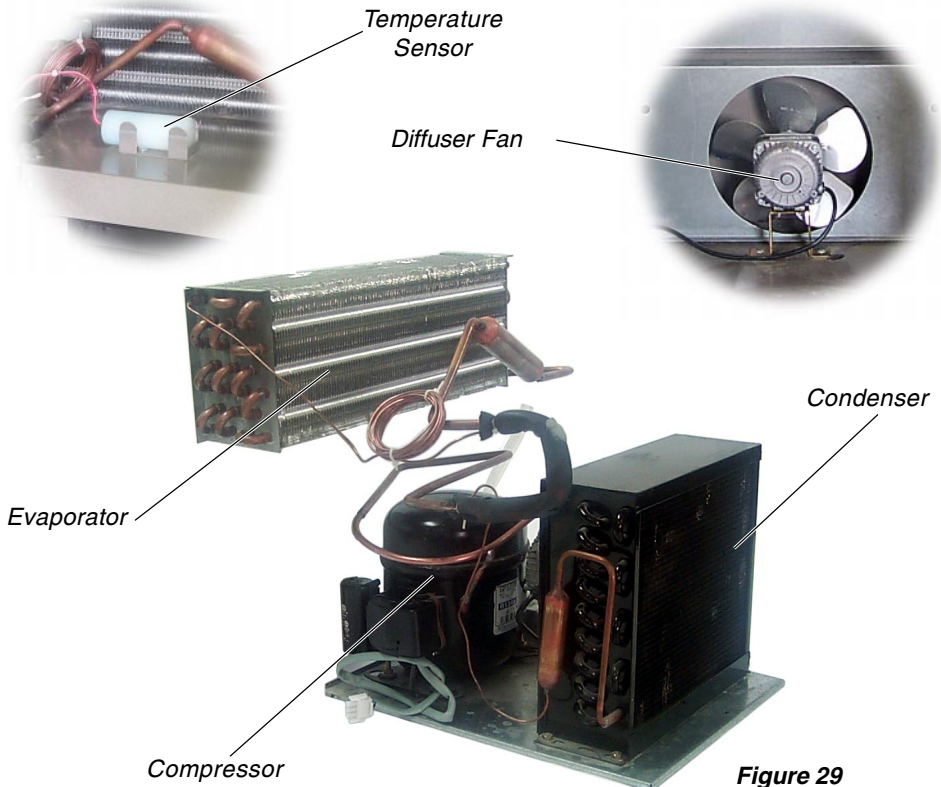

Figure 29

When the Control Card activates the Cold Group it does so using the I/O Card. From pin number 13 of U8 a "-" appears which activates relay (RL1) found on the Power Card which emits the phase (L2) needed by the Group in order to go into operation.

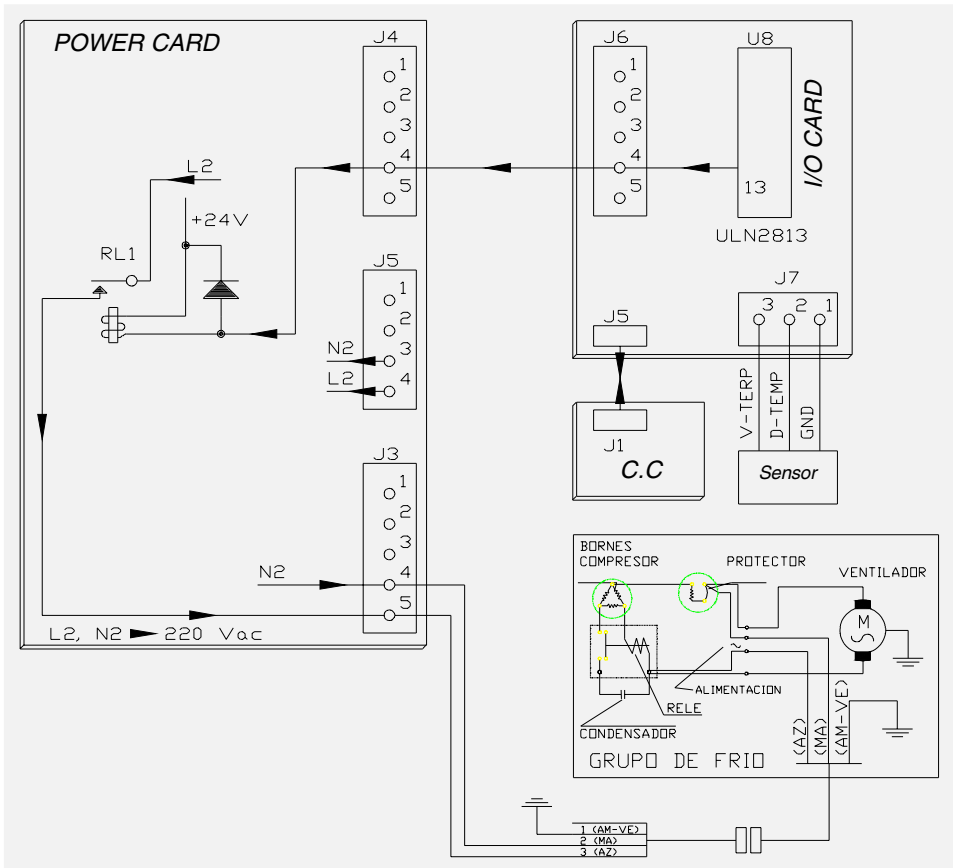

Figure 30

### 3.3.2 Electrical Operation of the Compressor

The compressor is an electric motor with possessing two coils, one being the main and the other the auxiliary or start up coil and for this purpose contains the following elements: a condenser, a relay, and a thermal protector or clixon (**figure 31**). Each time the compressor goes into operation, it does so with both coils, the main and the auxiliary or start up one. Once normal functioning level is reached only the principal coil remains functioning. To achieve this, it is provided with a start up relay (or intensity) whose reel is in series with the main coil. In this way start up tends to be accomplished by the main coil and power consumption is from 8-10 Amps, sufficient current to activate the relay

which has two which that connect a condenser of 47/56 uF. in series with the auxiliary coil creating a fictitious dephased phase in relation to the network and at the same time a magnetic field reinforcing the main coil capable of bringing the compressor into operation. When the compressor reaches 80% operating velocity consumption decreases to 2 or 3 Amps, enough current to maintain the start up relay activated. As a result, the auxilaury coil deactivates and disconnects so that the compressor continues functioning solely with the main coil. Each time the compressor stops and starts up the above process is repeated.

As a security device to prevent the compressor from reaching temperatures beyond 140 °C there is a thermal protector or clixon consisting of two bimetallic sheets which unite during stand by and close a circuit but separate when reaching a certain temperature and open the circuit thereby disconnecting power input. This clixon is in physical contact with the compressor housing.

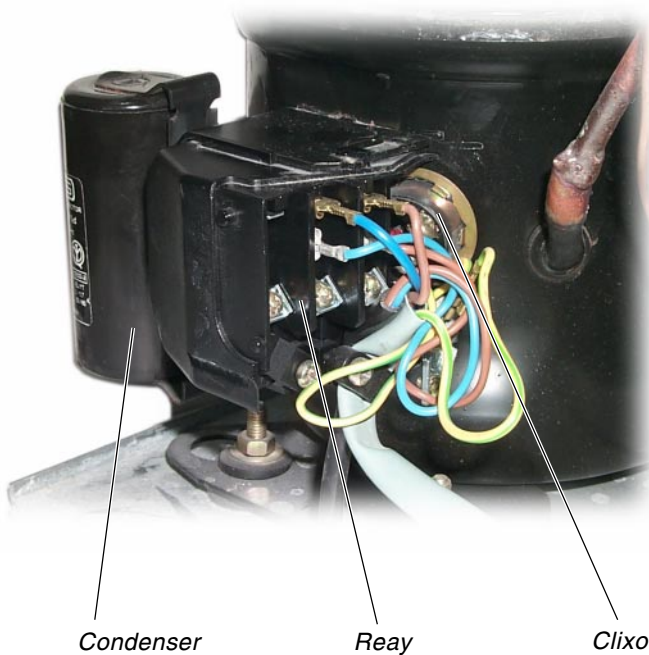
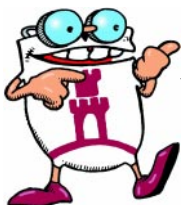

Figure 31



**REMEBER!!**  
**THE THERMAL PROTECTOR OR CLIXON AND THE START UP RELAY SHOULD BE THOSE RECOMMENDED BY THE COMPRESSOR MANUFACTURER OTHERWISE THE COMPRESSOR MAY NOT FUNCTION CORRECTLY.**

### 3.3.3 Refrigeration Components

#### COMPRESSOR

Its function is to pump the gas coming from the evaporator and compress it up to a pressure and temperature sufficient for extracting the heat latent in the condenser.

It is a hermetic compressor with a piston-type alternating movement. It is hermetic because it incorporates both the compressor mechanism and the motor for its activation within a hermetic deposit directly connected to the condenser and evaporator with which it forms a closed circuit. It is an alternating piston-type because the motor rotor is held to the axis of the compressor which incorporates a off-centered cam using a rod which converts the rotating movement of the motor into the alternating one of a piston. This type of condenser is by nature small and very silent.



Compressor

Figure 32

It is an alternating piston-type because the motor rotor is held to the axis of the compressor which incorporates a off-centered cam using a rod which converts the rotating movement of the motor into the alternating one of a piston. This type of condenser is by nature small and very silent.

#### CONDENSER

Its function is to convert the hot pressurised gas from the compressor into liquid. To do so, it radiates the latent heat of the refrigerant through its surface to the exterior using a fan. The refrigerant leaves the condenser as a liquid with continued high pressure.

The tube is of the finned-type with forced air circulation using the blades of an electric



Condenser

Figure 33

#### DEHYDRATING FILTER

Its function is to eliminate water content of the refrigerant when it leaves the condenser thus preventing the formation of ice in the interior of tubes impeding refrigerant flow. Water may also negatively affect the motor coil by contributing to the formation of acids.

A silica gel filter is used which acts through absorption without changes in its chemical state when water is collected.

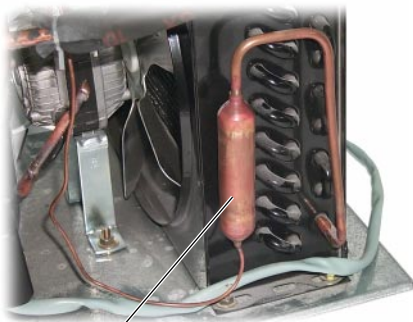

Figure 34

Dehydrating Filter



**CAPILLARY TUBE**

**Its purpose is to:**

- ✓ Regulate the quantity of refrigerant entering the evaporator thus reducing its pressure.
- ✓ Permit the rapid equalisation of pressures when stopped.

Part of the capillary tube in direct contact with the evaporator exhaust tube in order to produce heat interchange cooling part of the refrigerant and avoiding part of the evaporation produced in the capillary tube.

The capillary tube consists of a Ø 1.25 copper tube 4200mm long.



*Evaporator*

*Capillary Tube*

**Figure 35**

**EVAPORATOR**

Its purpose is to cool the medium in which it is found. It is an enclosed recipient with metallic sides where the refrigerant liquid proceeding from the compressor unit is boiled with the consequent absorption of the calories contained in the interior of the machine. To augment this effect a fan (figure 36) is employed to accelerate cooling throughout the product container.



*Product Container Fan*

**Figure 36**

This consists of a curved copper tube and aluminium fins firmly attached to the tube all with a coating of tin thus forming a compact body and improving thermal transfer.

**LIQUID SEPARATOR**

Its purpose is to retain possible refrigerant liquid leaving the evaporator without having evaporating thus avoiding the entrance of any liquid into the compressor which could damage it.

It is composed of a copper tube connected at one end to the evaporator and at the other to the compressor. The part leading to the evaporator bends downward thus the heavier liquid remains in the lower part of the tube while the gas in the upper part moves toward the compressor. Any existing liquid refrigerant also evaporates in this tube.

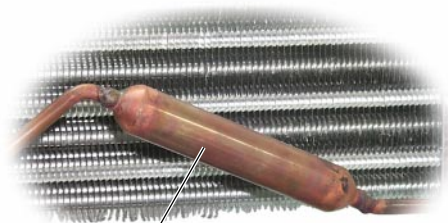

*Liquid Separator*

**Figure 37**

## 3.4 INPUT/OUT CARD

This is electrically situated between the Control Card and all peripherals.

It has several functions: as **input**, **output**, **power interface** for the Control Card, **low voltage** detection, and activation of the **safety relay** and **Ejecutivo coin mechanism**.

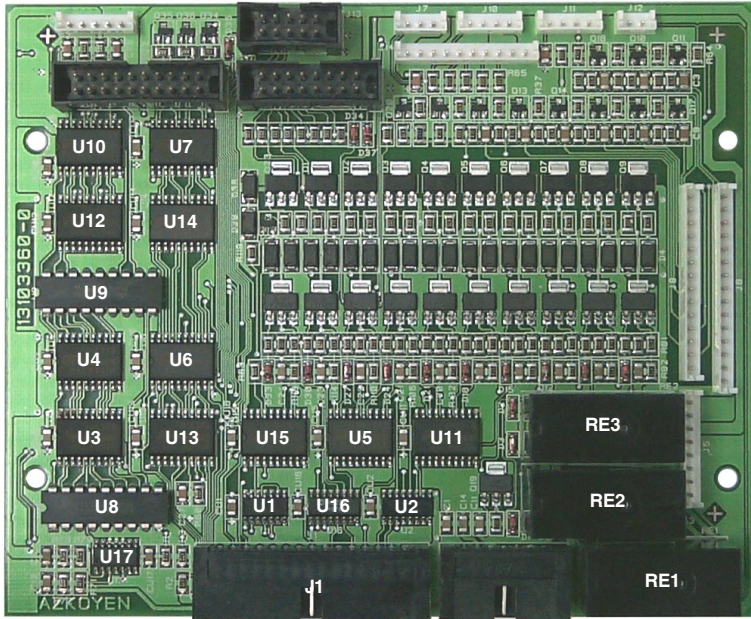

Figure 38

### 3.4.1 As Input

It receives all information sent by peripherals except exterior communication (with the coin mechanism which is received by the Control Card). All this information is adapted to the signal levels later required by the Control Card for their processing.

The circuits charged with performing this function are U11, U12, U13, U14 and U15. All are 74HC373 latched circuits which retain the information in their outlets and are governed by the Control Card through the U2 (74HC138) which is a decoder for activating the circuit corresponding in each case.

### 3.4.2 As Output

The Control Card sends activation orders to the peripherals, and to the Input/Output Card via its J1 connector.

The circuits charged with receiving this information are U3, U4, U5, U6, U7 and U10. All are 74HC273 latched circuits which retain information in their outlets and are governed by the Control Card through the U16 (74HC238) which is a decoder for activating the corresponding circuit in each case.

The outlets of the U3 and U4 are united to the U8 and U9 respectively which are ULN 2813 power circuits for activating the corresponding charges.

### 3.4.3 As Power Input Interface

It receives the Vcc power input from the Poer Card via the J6 connector and sends it to the Control Card via the J1 connector.

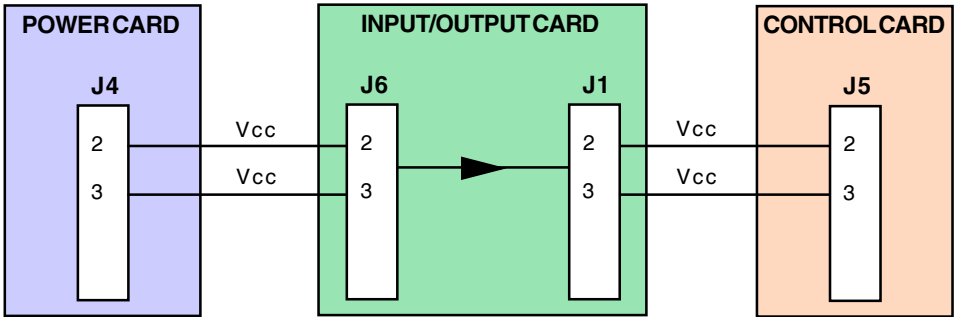

**Figure 39**

### 3.4.4 Low Voltage Detection

When the voltage goes 10% below the nominal, the machine shuts down. The control of the network voltage is achieved by controlling the 24 Vcc voltage creating a voltage divider with resistors R71 and R72 and applying the common point to the "+" of the operational amplifier LM324 (U17A) so that when the 24 Vcc diminishes by 30%, pin 1 of the U17A is tripped changing the +5 Vcc to 0 V and as it is connected to pin 18 of the U15, the latter informs the Control Card.

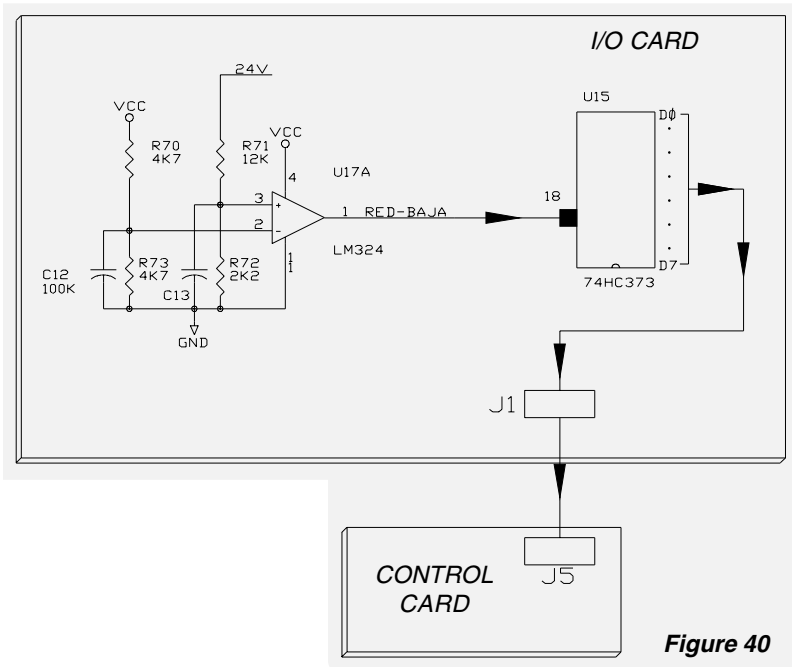

**Figure 40**



### 3.4.5 Safety Relay

This relay protects the machine against program malfunctions by disconnecting the 12 Vcc and 24 Vcc power inputs.

The machine activates this relay and deactivates it when it detects that it is performing incorrectly. This keeps the machine from expelling all of the product or admitting credit without being able to make any selections, etc.

The Control Card governs this relay which is situated in the I/O Card through the U3 and using the U8.

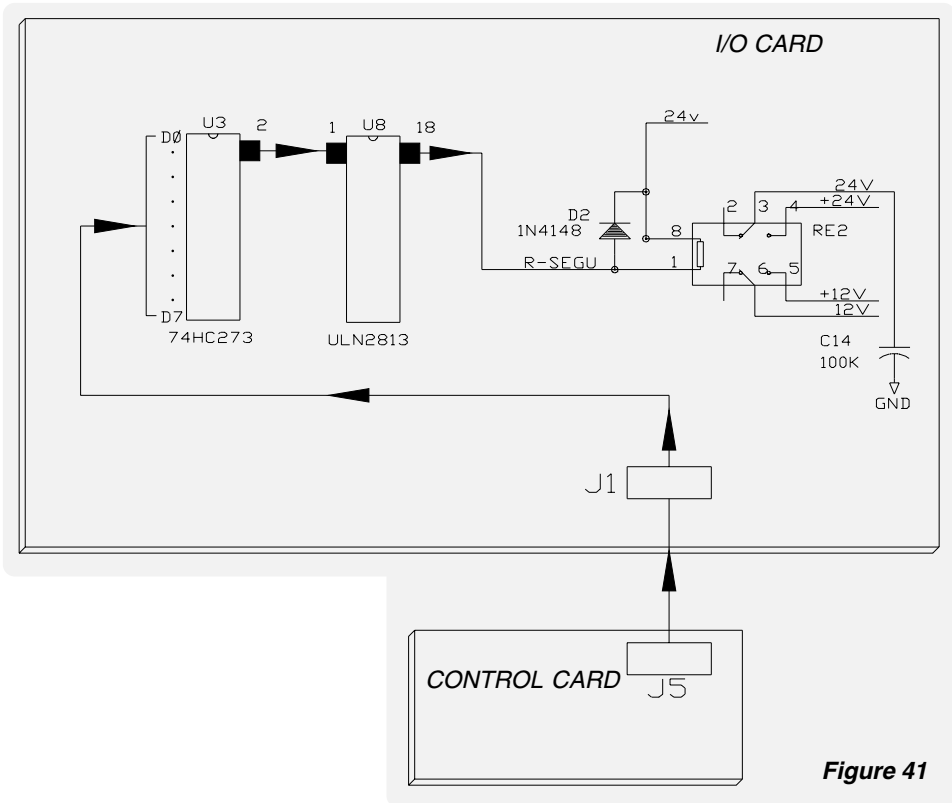

Figure 41

### 3.4.6 Power Input Relay for the Ejecutivo Coin Mechanism and Power Input for the MDB Coin Mechanism

The purpose of this relay is to provide power input of 24 Vac to the **Ejecutivo Coin Mechanism** for its operation.

It is governed from the Control Card using the U3 and through the U8.

Power input for the MDB coin mechanism is permanent and its value is 24 Vcc.

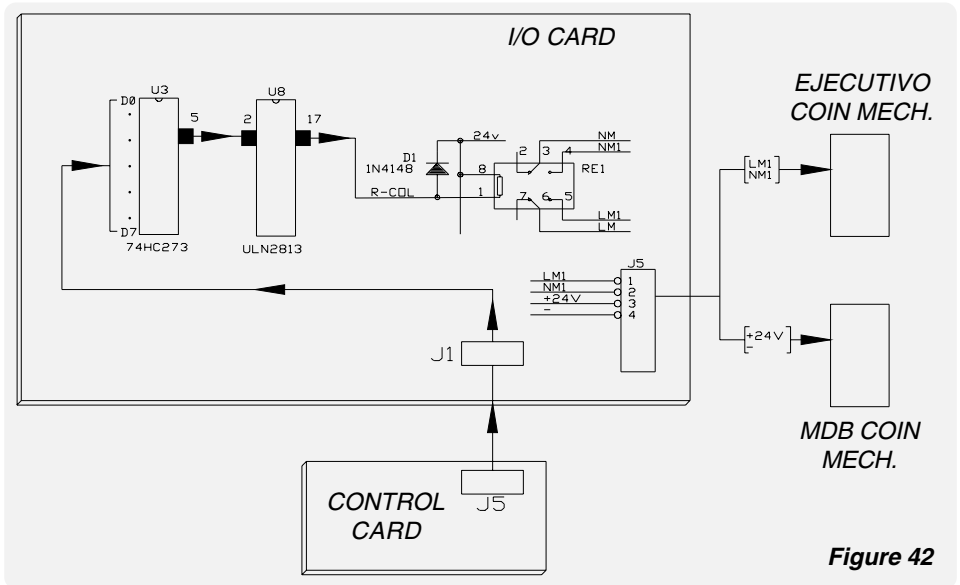
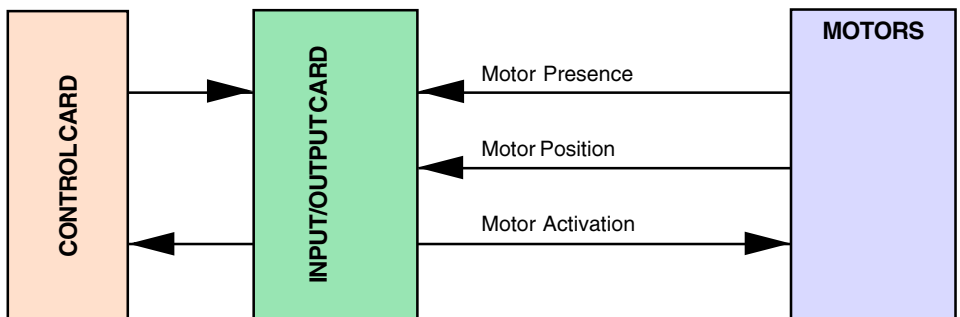

**Figure 42**

### 3.4.7 Input/Output of the Product Extractor Motors

The extractor motors are governed by the Control Card through the I/O Card.

In the same way **the detection of the presence and position of the motor** is conducted by the I/O Card and sent to the Control Card.



**Figure 43**



### 3.4.8 Product Extraction

#### Operation:

When acting, the motors are considered as the matrix of 7 rows (shelves) and 7 columns in model **H-70** and 8 columns in **H-80**.

When motor MAAs functions, +12 v must be sent by V-A and the GND via G-A.

When motor MGB functions, +12 v must be sent by V-G and the GND via G-B.

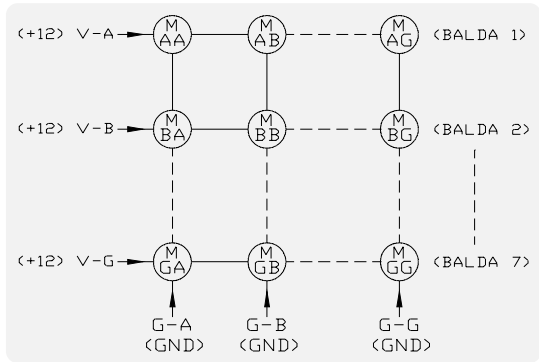
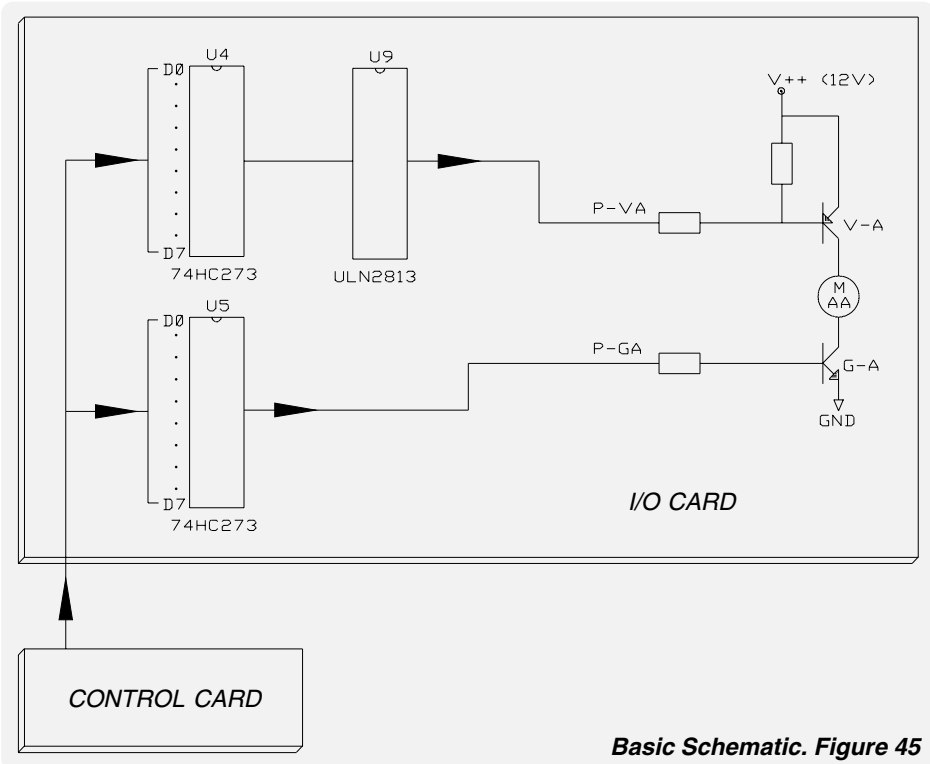

Figure 44



Basic Schematic. Figure 45

Each output of + 12 v.:V-A, V-B.....V-G, is governed by a control signal: P-VA, P-VB....P-VG respectively. These control signals exit the U9 which in turn is controlled from the U4.

Each output of GND : G-A, G-B..... G-G, is governed by a control signal: P-GA, P-GB...P-GG respectively. These control signals exit the U5.

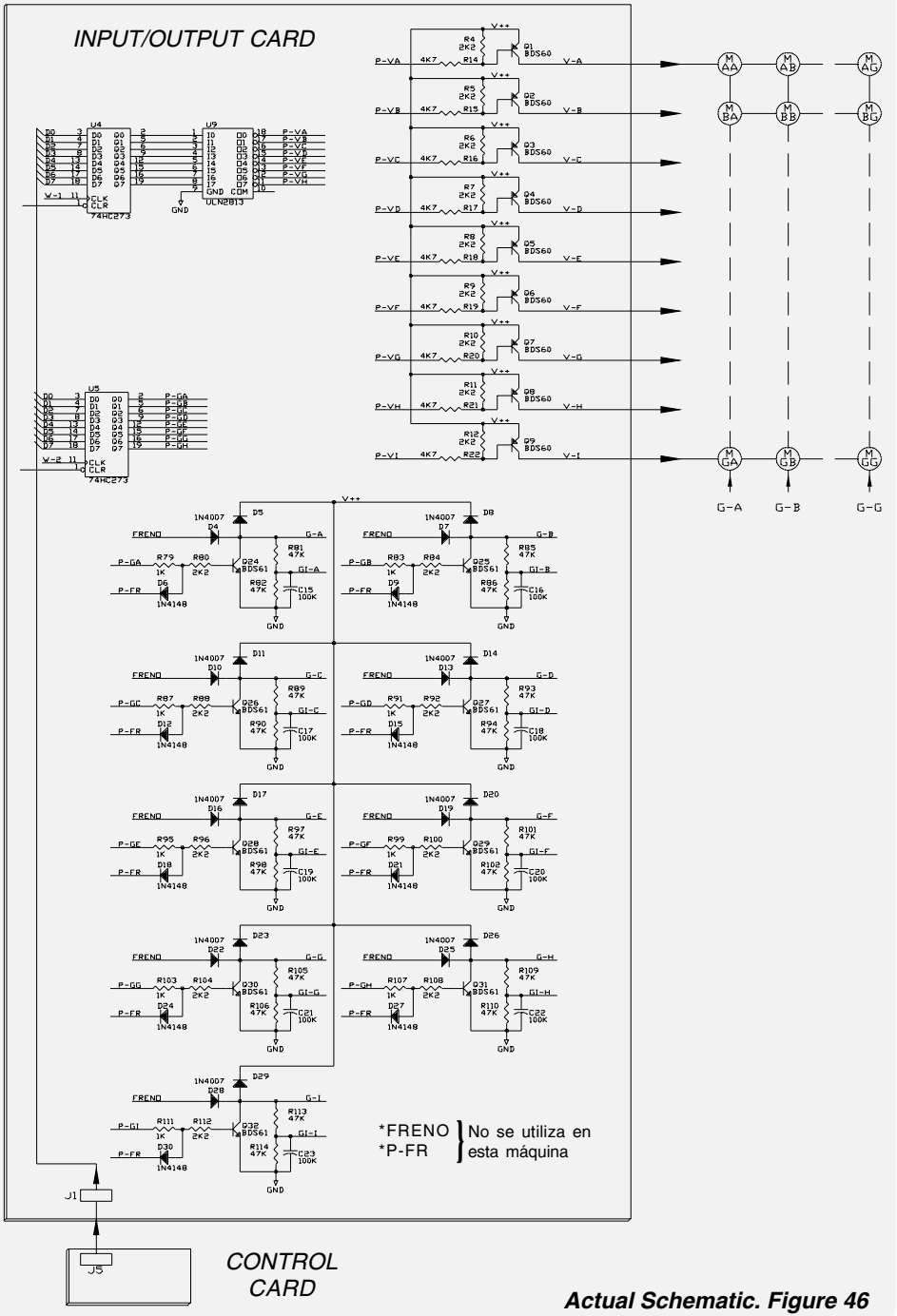

Actual Schematic. Figure 46

### 3.4.9 Motor Presence Detection

Each time service is requested from the machine, the Control Card confirms the existence of the motor for the selection requested via the I/O Card.

**Operation:**

+12 v are applied to the motor which is in series with a voltage divider composed of two resistors and the existing voltage between the common point and the negative is taken. If the measured voltage is 0v no motor exists and if the voltage is 5 v, one does. This information is sent to the U11 and then to the Control Card. As can be seen, activation is not necessary to confirm its existence.

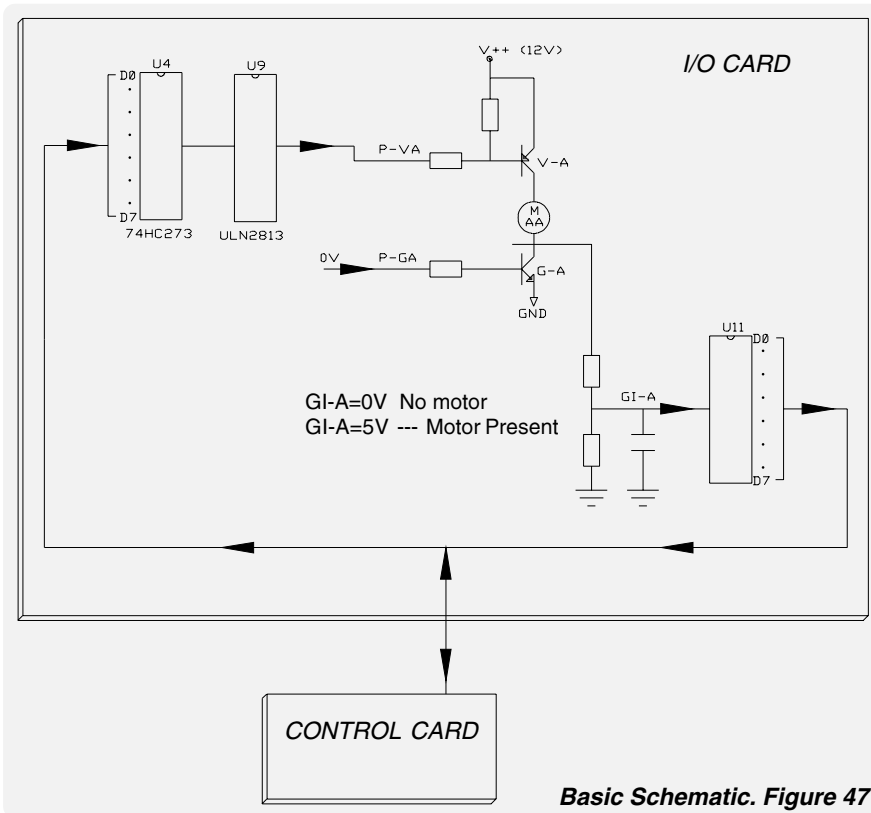

Basic Schematic. Figure 47



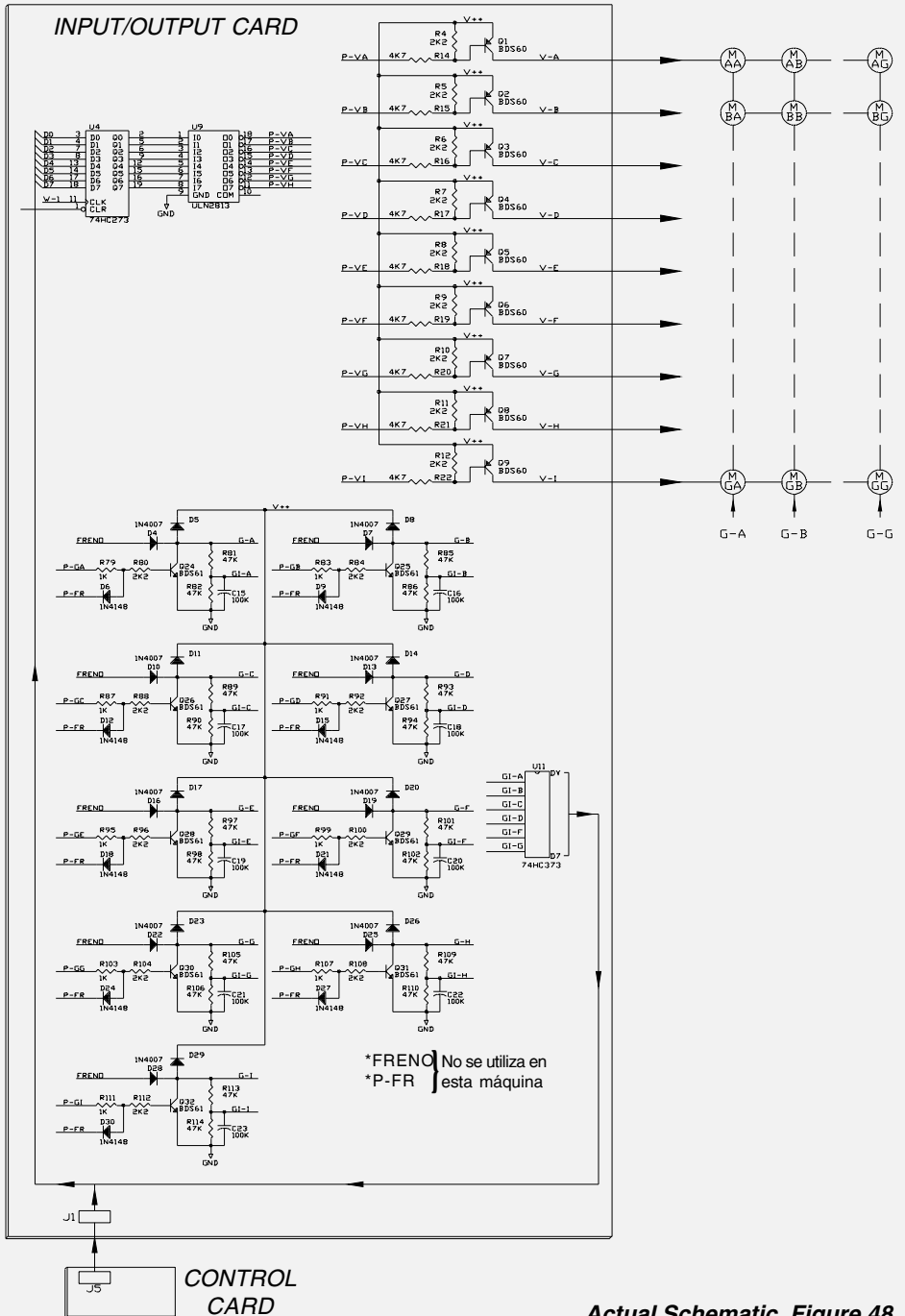

### 3.4.10 Motor Position Detection

In order for the Control Card to detect when the motor makes a 360° turn, it incorporates a run-end microswitch activated twice through a double cam when the turn is completed. Each run-end activation implies a 180° turn.

#### Operation:

The negative contact of the motor is applied to one of the ends of the run-end microswitch so that when this switch is closed it directly polarises the transistor passing the collector from 0v to 5v. This change in voltage is transferred to the U12 and from there to the Control Card thus informing it that the motor has performed a 180° turn.

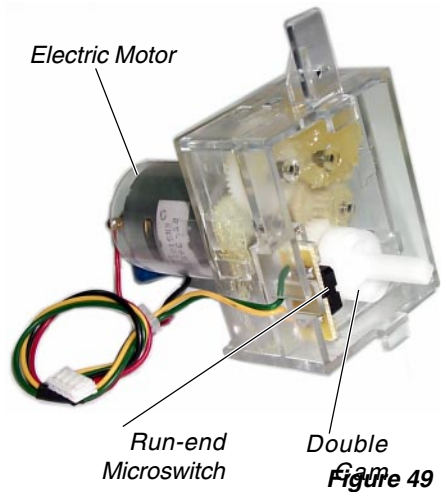

Figure 49

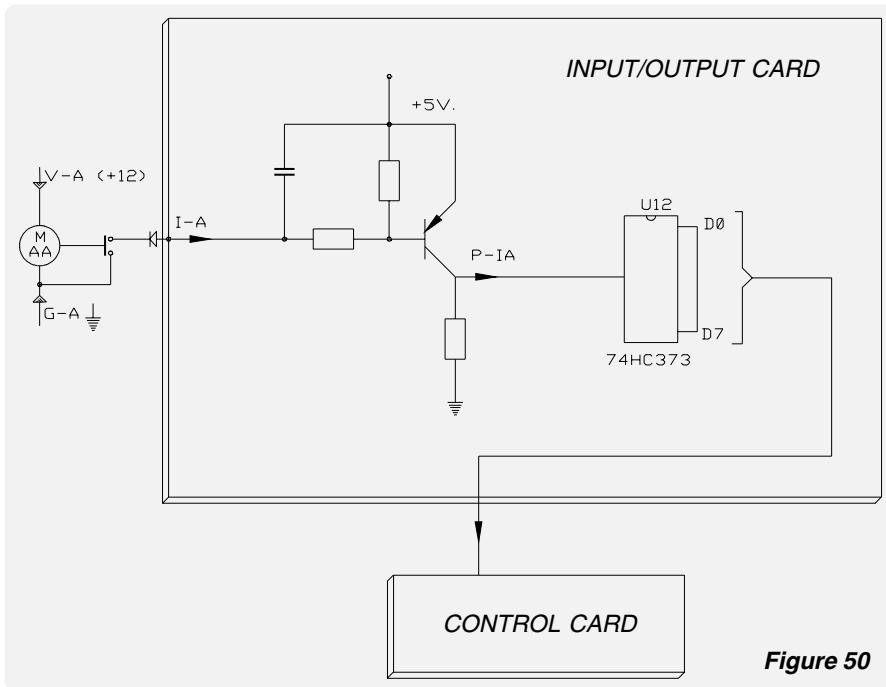

Figure 50

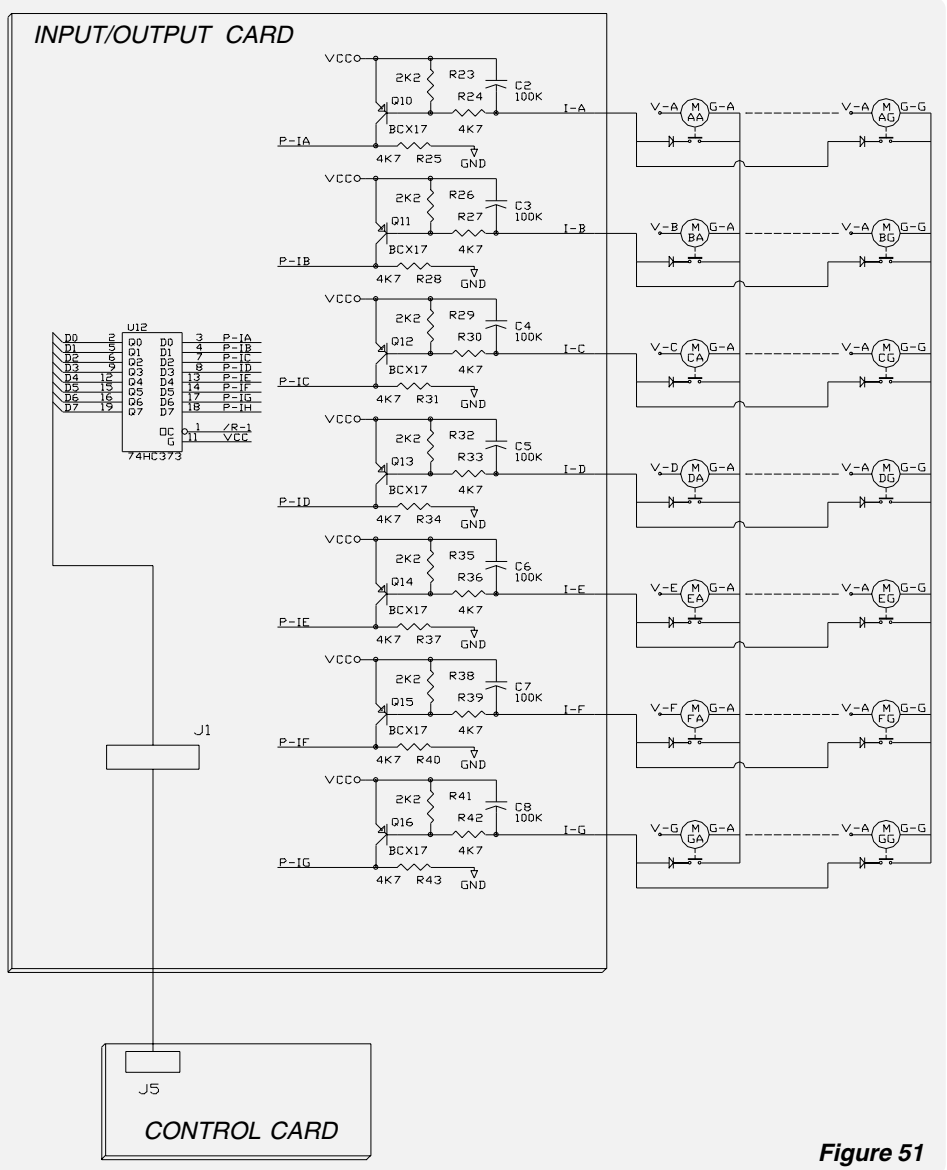

Figure 51

### 3.5 Shelf Card

In these cards the product extractor motors are connected and the I/O Card connection bundles run out from them.

Each shelf with motors has one of these cards. There are two types: one with 6 motors for the **Palma H-70** models and another with 8 motors for the **Palma H-87** models.

Each connector on the Shelf Card is identified with a letter: A, B, C, D, E, F, G and H which corresponds to the motor connected to it.

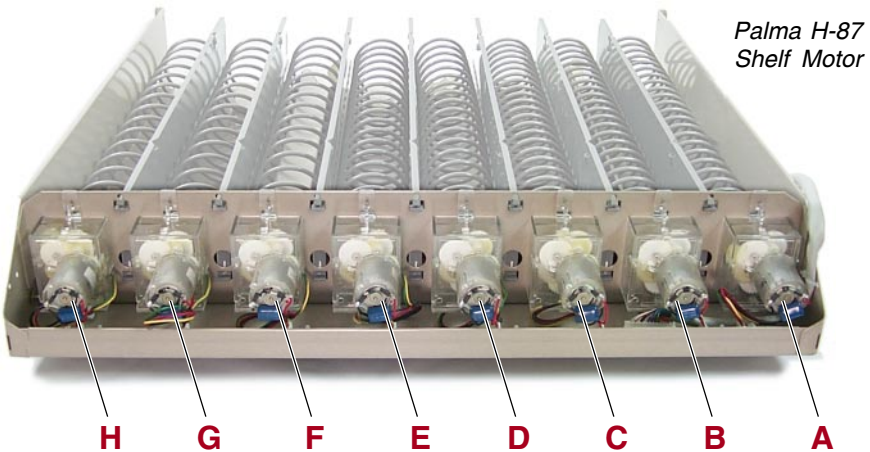
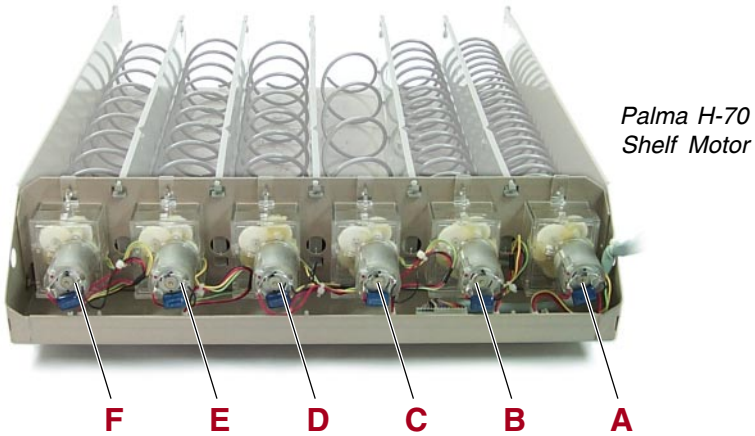

Figure 52

**Operation:**

Each extractor motor connector is composed of four pins and has 3 associated diodes and a condenser. The purpose of the diodes is to separate the different circuits from the rest of the motors.

The function of each pin is the following:

- **Pin 1:** Exits the GND when the corresponding run-end microswitch is activated.
- **Pins 2 and 3:** Enter the GND to power the motor and the run-end microswitch.
- **Pin 4:** Enters the +12v to power the motor.

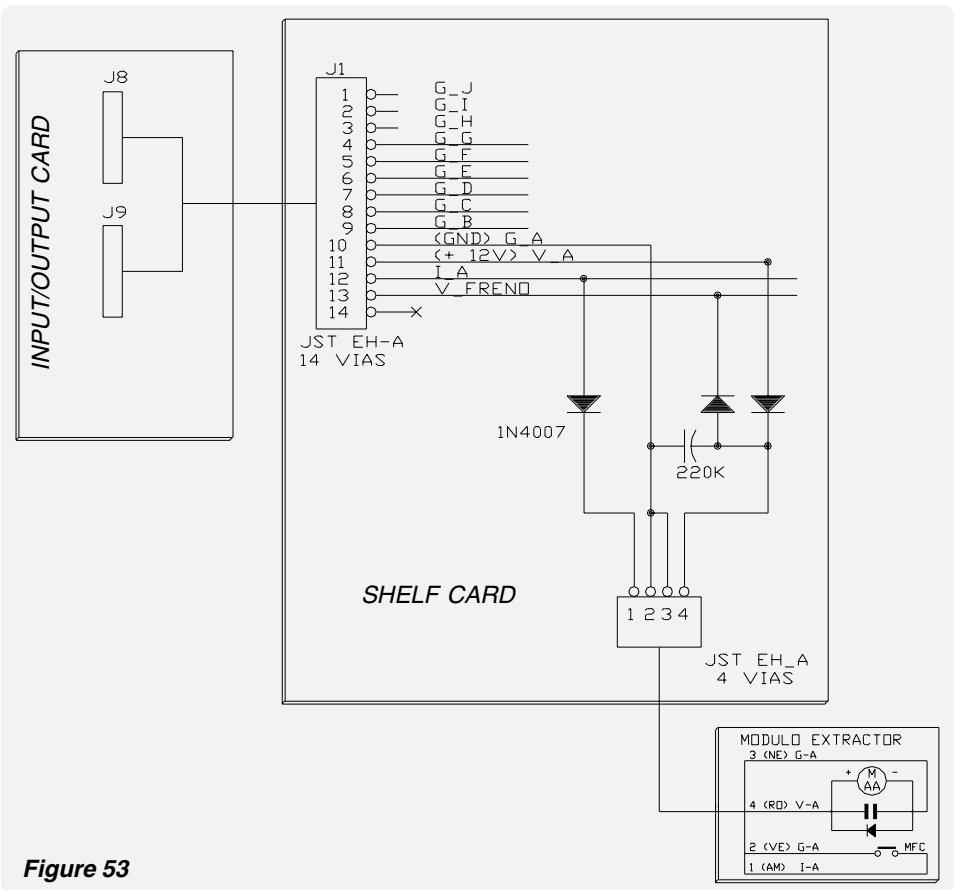
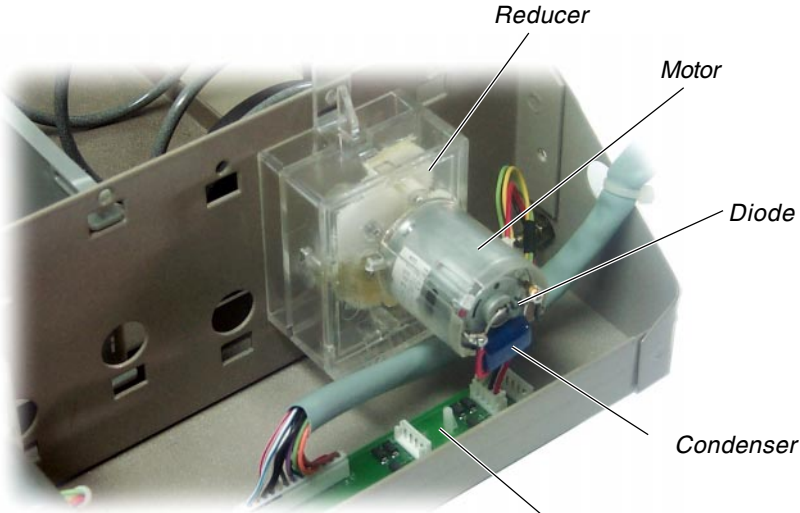

**Figure 53**

### 3.6 Product Extractor Motor

Its function is to move the coil to extract the product.

It consists of a motor, a reducer, a run-end microswitch, a diode, a condenser and a connection bundle.



Shelf Card **Figure 54**

**Operation:**

The motor operates on 12 Vcc, the + (V-A) is applied to pin 4 and the - (G-A) to 3. This motor has a diode and a condenser connected to the power input terminals whose purpose is to eliminate the peaks produced in the motor coil during start ups and shut downs.

The - (G-A) reaches the run-end microswitch from the Shelf Card through pin 2 and this -(G-A) appears in pin1 when it is activated by the cam that is joined to the reducer.

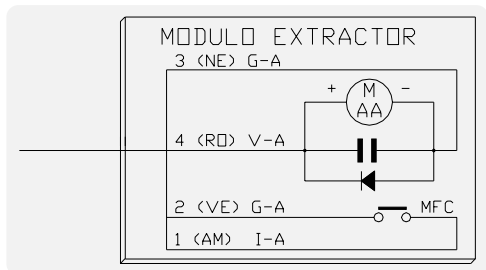

**Figure 55**

## 3.7 Display Card

Its main function is to establish audio-visual communication between the machine and its user. It does so with an illuminated LCD display with 26 characters and two lines as well as four lights of the LED type which illuminate the **"Sold Out"** and **"Exact Change"** messages.

The messages shown in the display are: time, date, temperature, publicity message, credit, malfunctions, and programming functions.

It also incorporates the following elements:

- The coin return button
- A programming access button
- A beeper
- An infrared reception-emission card connector.

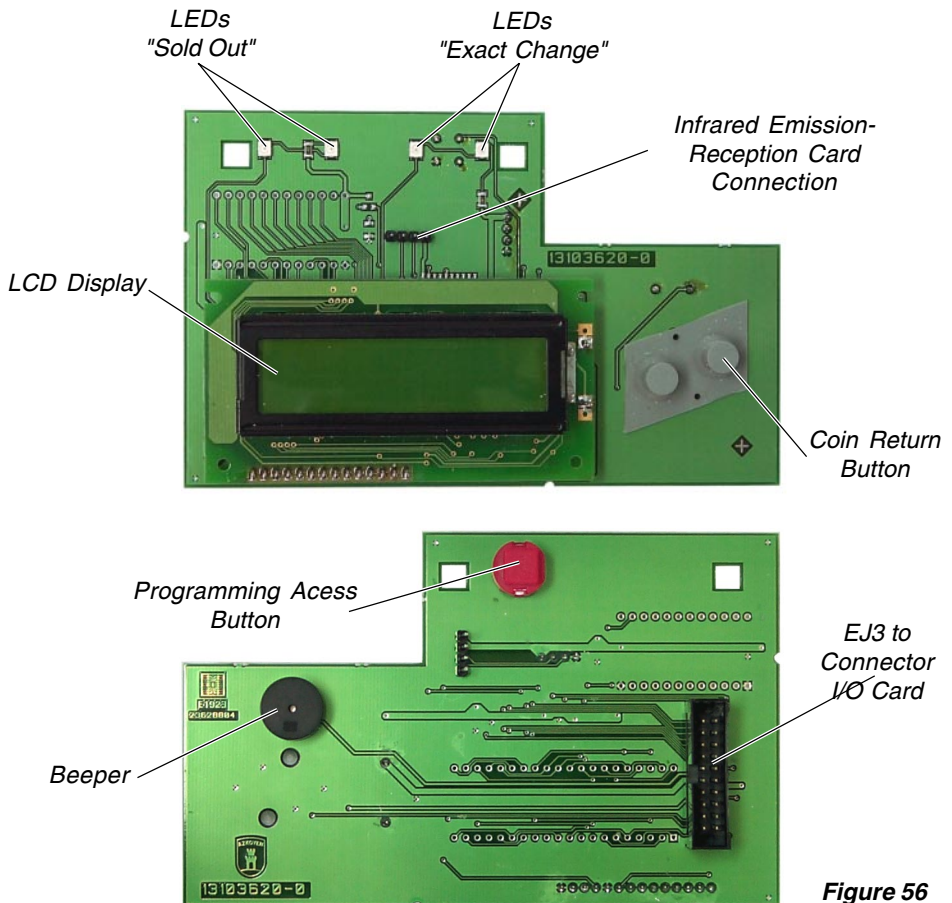

**Figure 56**



### 3.7.1 LCD Display Function

From the U7 and the U10 of the I/O Card and via the J4 connector the data and control signal bus runs out to make the display function. All signals appear in the display via the J3 connector.

The display is connected to the J1 connector and to this connector the data bus, (Dat\_0.....Dat\_7), control signals (CSLCD and DIRLCD), and the VDD input arrive.

By applying the data bus and control signal (DIRLCD) to the U1 (74HC273) the signal that activates the display illumination (LLCD) and the control signal for the display (RS-LCD) are achieved.

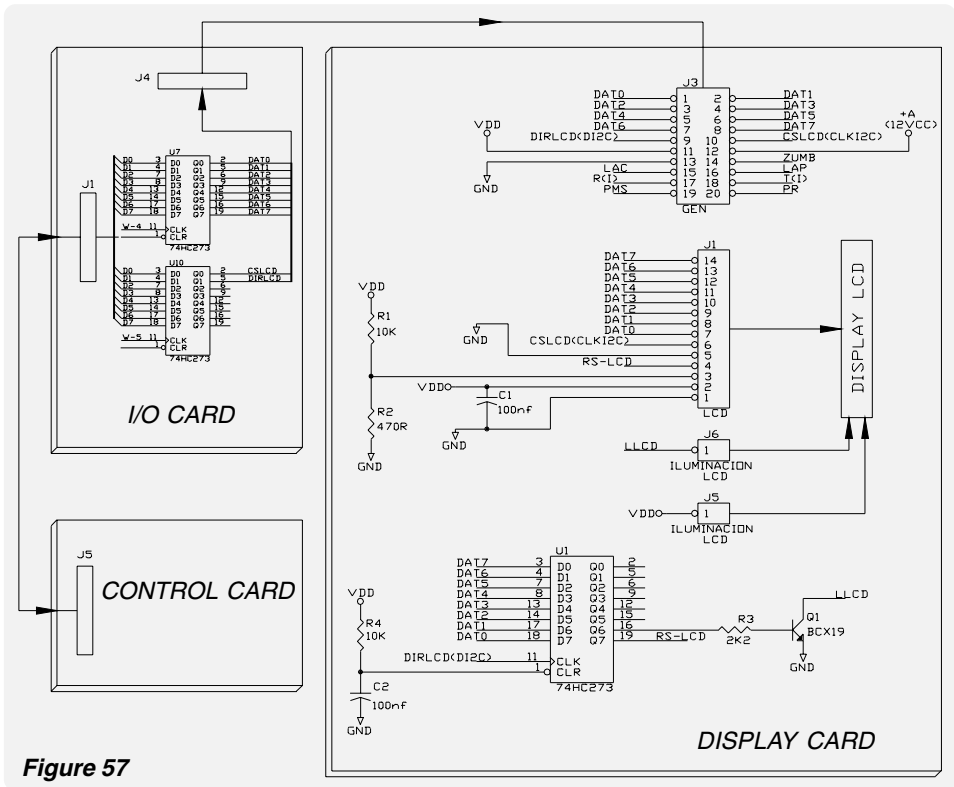

Figure 57

### 3.7.2 Sold Out Light

Its function is to light up when a product is selected in a coil that is not operative. It consists of two LED diodes for SMD.



"Sold Out"

Figure 58



**Operation:**

Using the data bus (D0...D7) sent by the Control Card to the U10 of the I/O Card an outlet is activated that directly polarises transistor Q35. In consequence the GND (-) appears in the collector of this transistor to power the two LED diodes located on the Display Card.

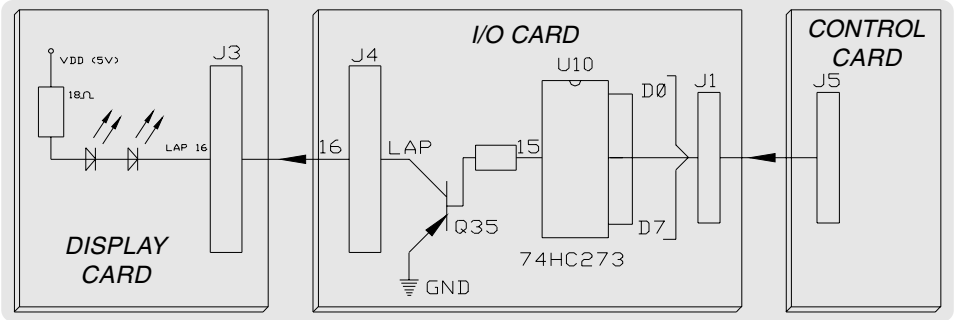

**Figure 59**

**3.7.3 Exact Change Light**

Its function is to light up when there are not sufficient coins in the machine to guarantee correct change return. It consists of two LED diodes for SMD.



*"Exact Change"*

**Figure 60**

**Operation:**

Using the data bus (D0...D7), sent by the Control Card to the U3 of the I/O Card, an outlet is activated that polarises an entrance to the U8. As a consequence the GND (-) appears at its exit to power the two LED diodes located on the Display Card.

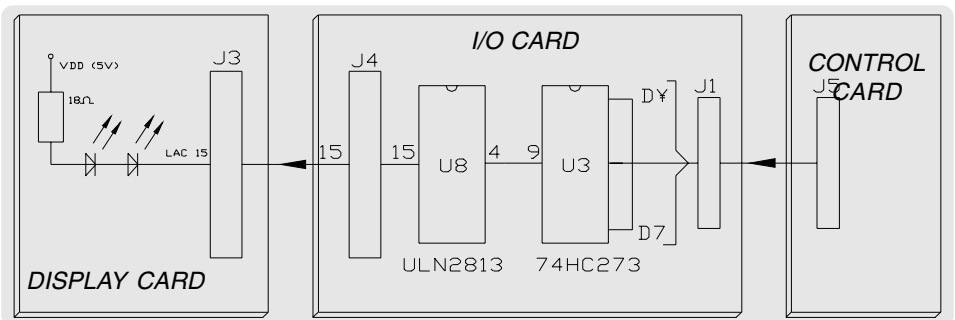

**Figure 61**



### 3.7.Coin Return Button

It is a button whose purpose is to recover the existing credit when pressed.

It consists of two rubber membrane button with graphite contacts in the buttons as well as on the printed circuit. They are electrically parallel which facilitates their pressing regardless of the pressure angle.



Figure 62

#### Operation:

When the coin return button is pressed the GND (-) is sent to the J3 connector of the Display Card and from there to the J4 connector of the I/O Card where it is directed to the U13 for later processing to the bus (D0....D7) which goes to the Control Card thus permitting it to be informed that coin return is being requested.

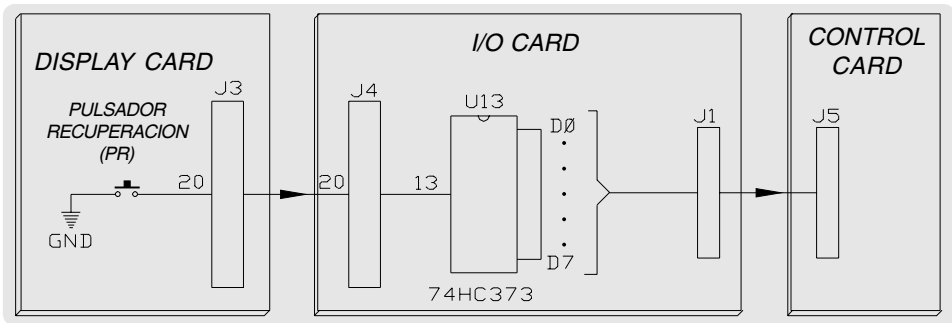

Figure 63

### 3.7.5 Programming Button

Its purpose it to permit access to programming.

#### Operation:

When the programming button is pressed the GND (-) is sent to the J3 connector of the Display Card and from it to the J4 connector of the I/O Card where it is directed to the U13 for later processing to the bus (D0....D7) which goes to the Control Card thus permitting it to be informed when entrance into programming is being requested.



Figure 64

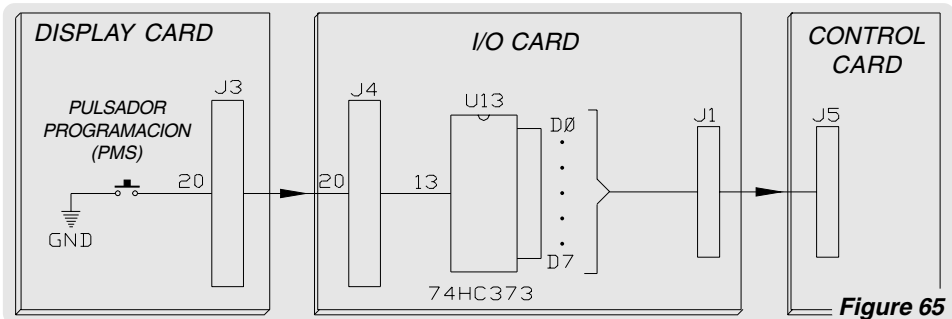

Figure 65

### 3.7.6 Beeper

This is an electrical device whose function is to emit a beep each time a button on the machine keyboard is pressed. It also works simultaneously with the "Sold Out" and "Exact Change" lights.



Figura 66

**Operation:**

Its operation is comprehended between 3Vcc and 16 Vcc, but in this application 12 Vcc are used.

The GND (-) terminal is applied from the transistor Q36 which is polarised by the U10, with both components being located on the I/O Card.

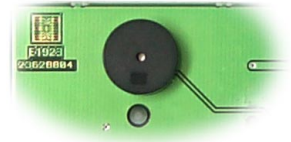
This beeper control as the previous ones, is governed by the machine Control Card using the data bus (D0.....D7) applied to the U10 on the I/O Card.

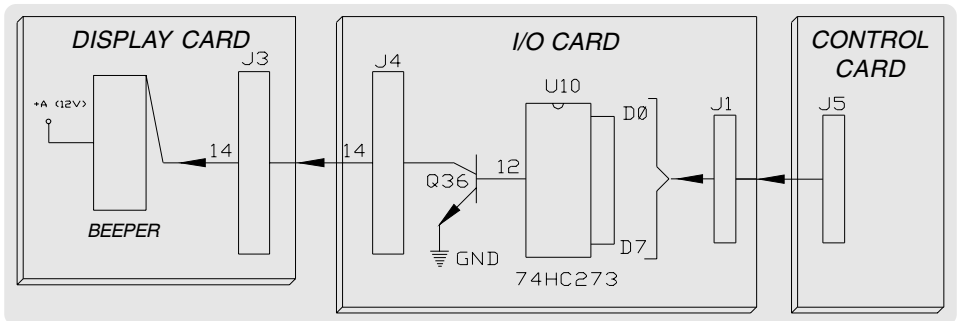

Figure 67

### 3.8 Keyboard

It consists of twelve steel laser-engraved buttons, each of which acts upon a rubber membrane keyboard with their graphite contacts in the buttons as well as the printed circuit.

#### Operation

They form an electric matrix of 12 buttons so that each time one is pressed an "SL" line is united with another "RL" line which is sent to the U14 of the I/O Card which in turn is incorporated into the data bus (D0....D7) to the Control Card thus informing it which selection has been pressed.



Figure 68

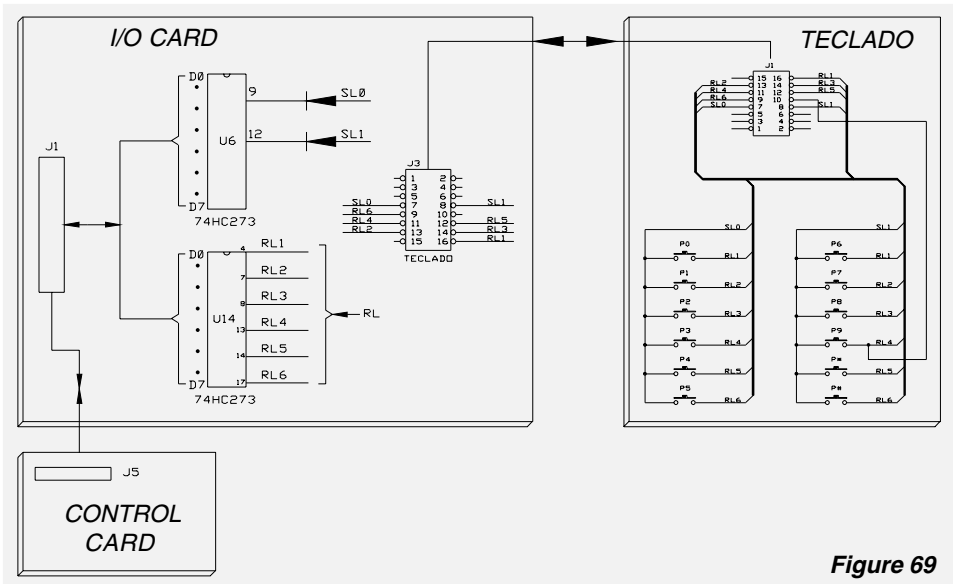

Figure 69

## 3.9 Programming Box

It is composed of four metallic membrane buttons mounted on a printed circuit card.

Its main function is to access programming and modify it although it does have others such as putting the machine in open sale mode during a service, showing the temperature and erasing the memory.

### Operation

Electronically a four-button matrix is formed so that each time one of them is pressed the "SL" line is united with another "RL" line which sends the U14 on the I/O Card which, in turn, is incorporated into the data bus (D0....D7) to the Control Card thus informing it which key has been pressed.

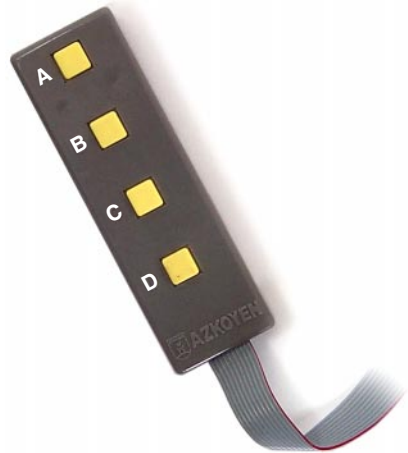

**Figure 70**

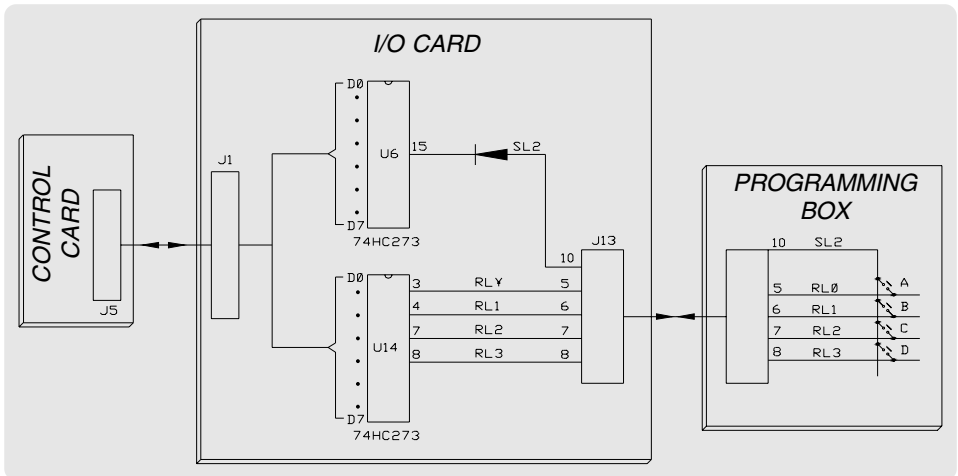

**Figure 71**



### 3.10 Temperature Sensor

It is composed of the DS1821 circuit which is a programmable digital thermostat capable of functioning as a thermometer and thermostat although the application used in this machine is that of thermometer.

#### Operation

Functioning as a thermometer is continually sends data via "D-TEMP" through pin # 17 of the U15 in whose outlet the " D-TEMP " appears incorporated in the data bus when required by the Control Card.

This sensor is powered from the " V-TEMP " which is approximately  $V_{cc}$  since the transistor Q34 is permanently cut.

The I/O Card is also qualified to function as a thermostat although, it does not do so at the moment. To do so, it incorporates three transistors: Q20, Q21 and Q34.

In order to function as a thermostat the sensor must be programmed. To do so, it must be disconnected from any input and a series of impulses must be introduced via the U6 transistors Q20 and Q21. To neutralise its input the transistor Q34 is polarised via the U10 As a consequence,  $V-TEMP=0v$  and later impulses are obtained through pin 19 of the U6 which polarise Q20 and Q21, activating D-TEMP.

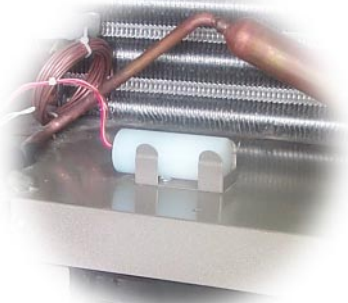

Figure 72

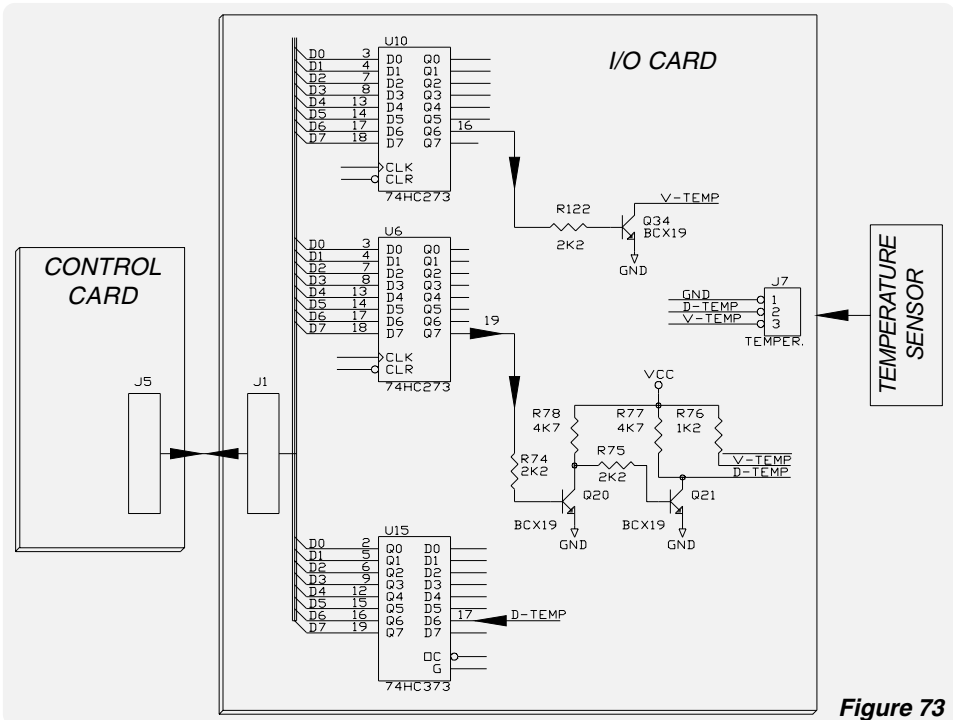

Figure 73

## 3.11 Coin Return Module

Its consist of:

- ✓ A motor 24 Vcc + reducer
- ✓ A diode and a condenser placed in parallel with the motor
- ✓ A run-end microswitch
- ✓ A selector opening lever activation system

Its purpose is to activate the selector opening lever when the machine returns coin thus performing two functions:

- 1) When the selector is opened, possible jamming inside it is eliminated.
- 2) When the selector is opened, it sends a coin return code to the corresponding coin mechanism Control Card indicating that a coin return is being made and that change coins should be extracted, if applicable.

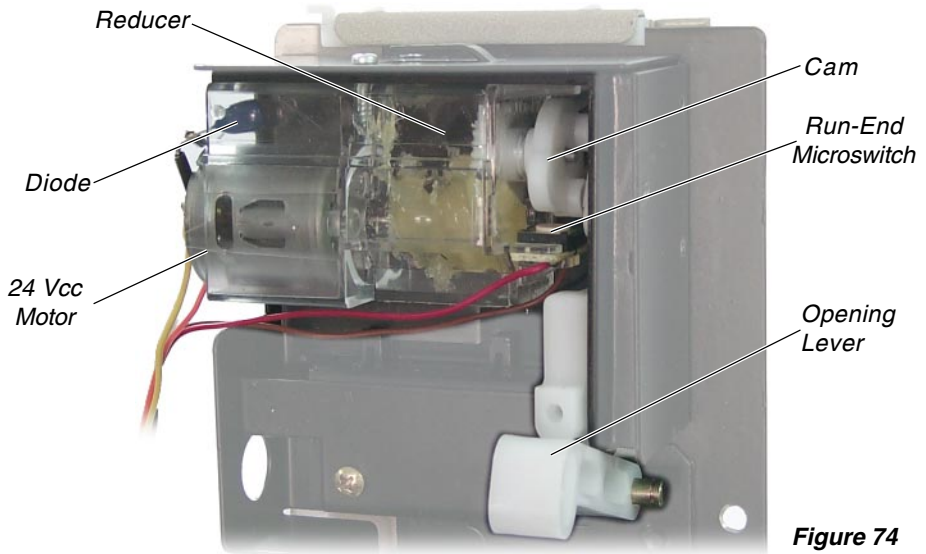

**Figure 74**

### Operation:

The Control Card governs the operation of this motor through the I/O Card.

The power input is 12 Vcc. The +12 is sent directly and is governed by the "GND".

When the Control Card wishes to perform a coin return, it does so via the data bus (D0....D7) activating pin 19 of the U10 which directly polarises transistor Q19 with the "GND" appearing in the collector which, being in direct contact with the coin return motor terminal, puts it into operation.



The positioning of the motor is controlled by a run-end microswitch each time the reducer makes a 360° turn. It has a cam incorporated to the axis which activates this run-end microswitch. This switch consists of a button with a negative (-) connected at one end and when it is pressed by the reducer cam, the negative charge passes to pin 14 of the U13 which passes it on the data bus so that the Control Card processes it and registers that the 360° has been made.

In parallel with the motor are connected a diode and a condenser whose function is to annul the effects produced by the motor coil when voltage is applied on and off.

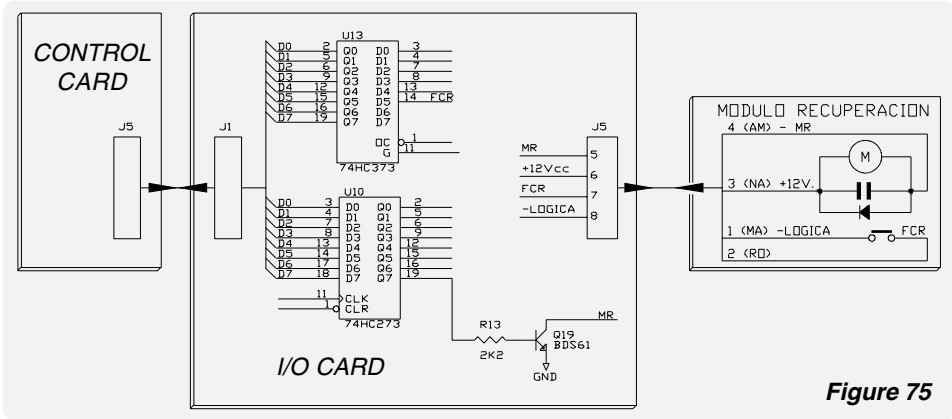

Figure 75

### 3.12 Control Card

Its function is to exercise complete control over the entire machine. All information sent by the peripherals via the I/O Card is processed and corresponding elements are activated. The only direct communication made with a peripheral is with the coin mechanisms.

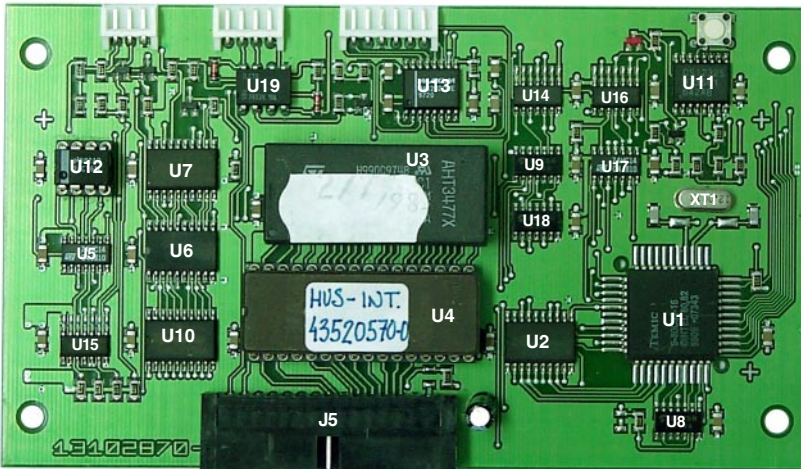
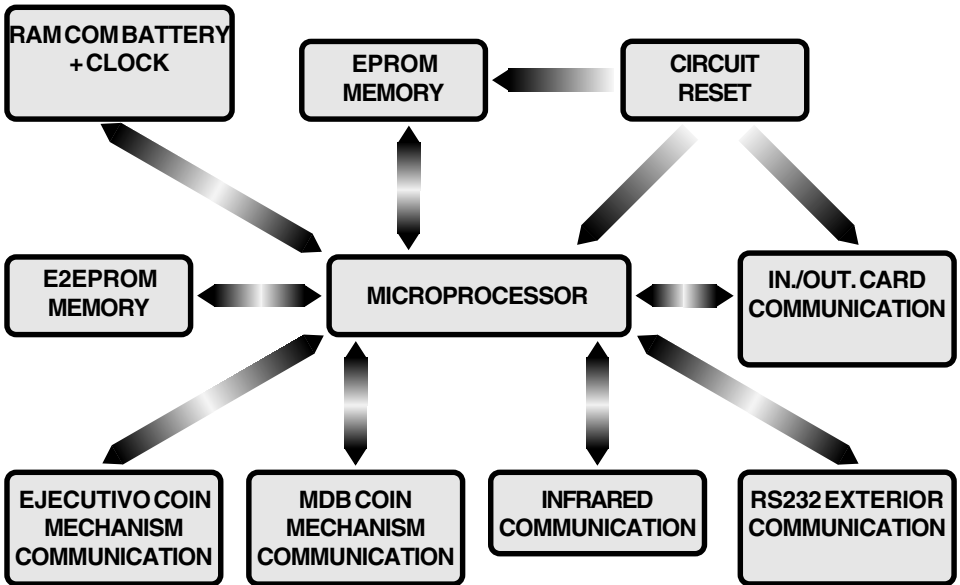

Figure 76



**Operation:**

The schematic in block is the following:



**3.12.1 Eprom Memory**

This is U4 whose designation is 27C010 with a capacity of 1Mbit. It is a "Read Only" memory although it can be erased with ultraviolet light in order to be re-recorded.

In this memory the program and all functioning instructions for the machine are recorded, i.e., the "personality" of the machine or its modus operandi is recorded.

It is mounted on a base to facilitate its substituting foreseeing possible expansions and improvements in the program.

Once the machine is turned on it continually repeats execution of the instructions recorded in this memory.

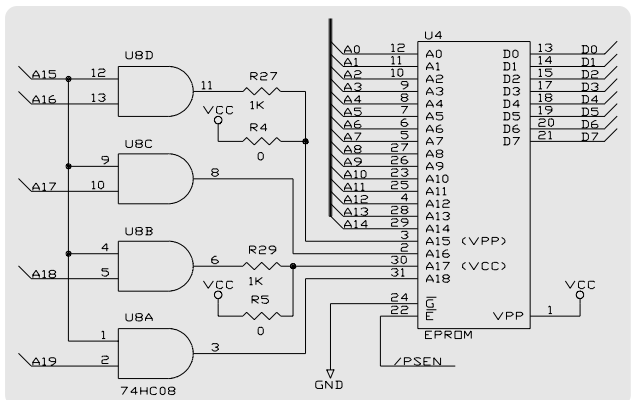

**Figure 77**



A0.....A18 are positions in the memory where the corresponding data bus D0....D7 is found.

Above the memory a decal with an 8-digit number plus a hyphen is located which identifies the program incorporated into the memory. Possible modifications in the program would produce an advance of the number to the right of the hyphen.

### 3.12.2 RAM

It is both a reading and scripting memory in which data is continuously modified according to the operations being performed by the machine.

It consists of the U3 whose designation is M48T18 with a 64kB bit capacity. It incorporates a clock and a lithium battery so that from neither the memory nor the clock is lost should the machine lose power.

This memory stores all data necessary so that no data is lost when the machine is turned on and off.

The microprocessor directs the data bus D0...D7 via A0....A12 each time recorded data is modified.

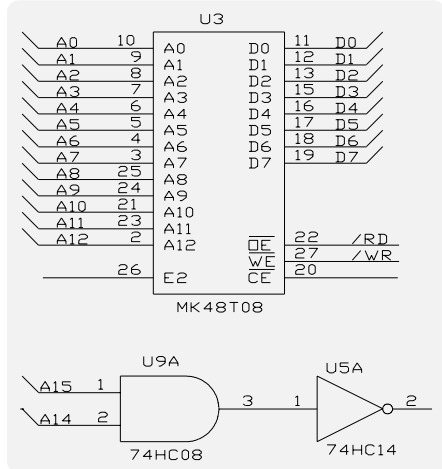

Figure 78

### 3.12.3 EEprom Memory

This is U12 designated 24C16 with a 2Kbit capacity.

It is a reading and scripting memory and in the absence of power it maintains the information recorded in it. It serves as a back up copy of the information necessary for the correct operation of the machine in case the RAM should be lost.

Transfer of information from the RAM to the EEProm memory is via a I<sup>2</sup>C data bus.

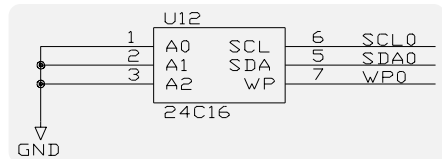

Figure 79

This memory is constantly recording the following data: machine number, operator code, personalised menu, publicity message, coin, language, simple vend (MDB), open sale, time, clock options, beeper, temperature message, temperature, temperature configuration (one or two zones), maximum acceptance (MDB), daily and weekly illumination cycle, daily and weekly group start up, prices, impulses, family and product code, promotions, canal association, and events log.

When the machine is turned on, it starts up with the data contained in the RAM after comparing the check-sum with the E2Prom memory. Should any discrepancies appear, start up will proceed with the EEPROM memory.

**DON'T FORGET!!**

When you wish to change the Control Card without losing stored RAM information:

- 1)- The Eprom memory must have the same reference.
- 2)- The EEPROM memory of the card removed must be inserted.

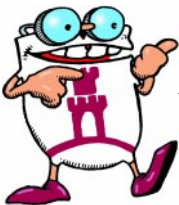

### 3.12.4 Microprocessor

This is U1 designated 80C32. This circuit's function is to execute the program recorded in the Eprom memory. It coordinates the operation of all the elements composing the Control Card. The data and directory buses for accessing and activating the rest of the components originate here. It is associated with the U2 which is a 74 HC 373 circuit for converting the data bus into directories when necessary.

The operation rhythm is set by the (XTAL) quartz oscillator whose functioning frequency is 12 MHz/s.

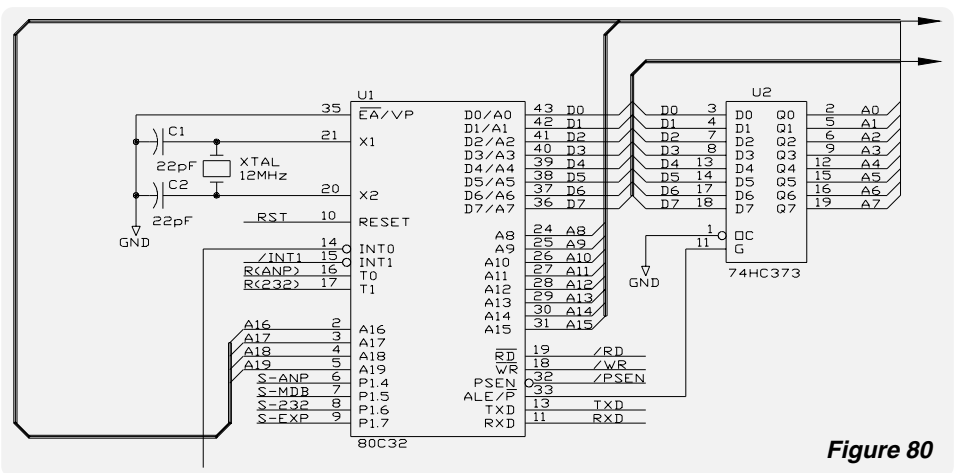

**Figure 80**



### 3.12.5 I/O Card Communication

Latch circuits U6, U7 and U10 perform this maintaining output while input is unchanged.

These circuits are governed by the microprocessor and orders are sent via them to the I/O Card and thence to the respective peripherals.

U10 has a double function: sending the data bus (D0...D7 ) to the I/O Card and receiving the other data bus from the I/O Card.

The U6 emits the WDOG which goes to the reset circuit. This signal verifies that the program is being correctly executed otherwise its absence resets the entire Control Card.

A0.....A7 are the directories for selecting the corresponding I/O Card circuit.

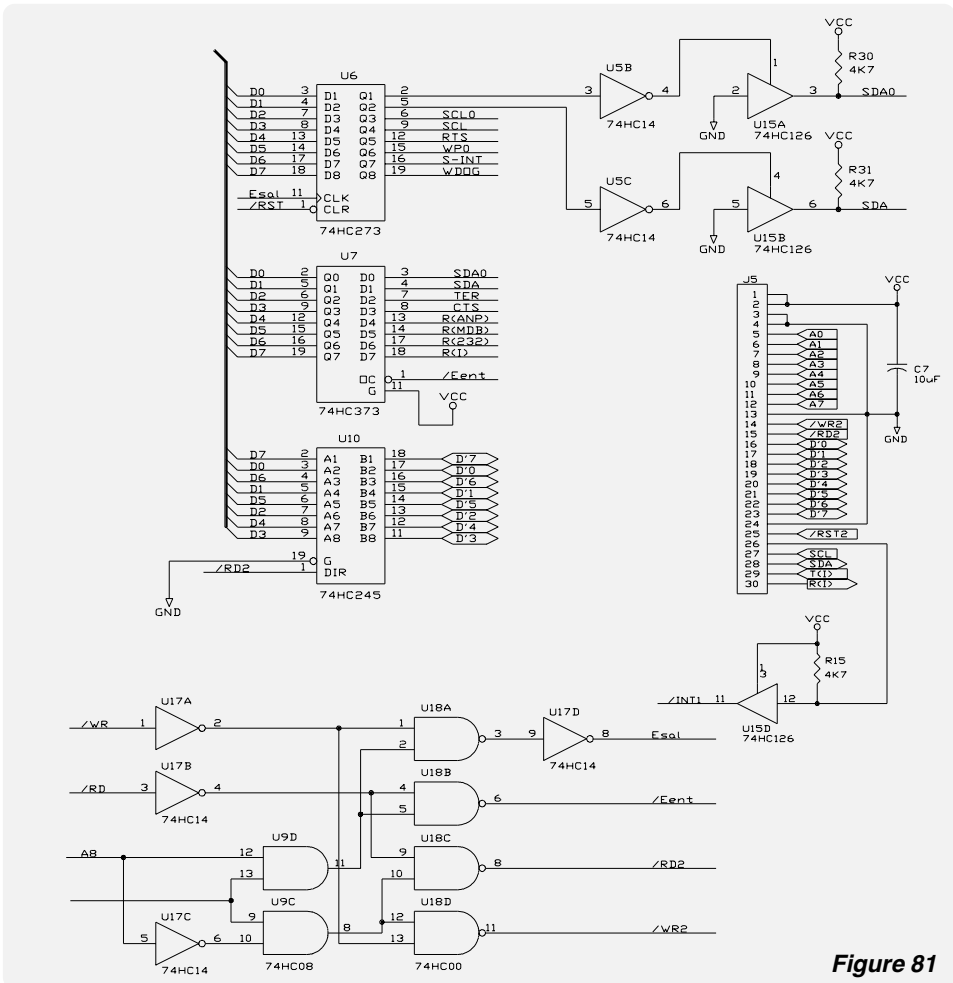

Figure 81

### 3.12.6 Reset Circuit

This function is performed by U20 designated DS1232.

When the machine is connected this circuit resets all circuits to zero for a certain time insuring that all circuits are initialised under the same conditions.

The Control Card has a button for manually resetting and initialising the machine and a red LED diode that remains lit when the program is being executed correctly and blinks when the card is resetting causing the program to run incorrectly.

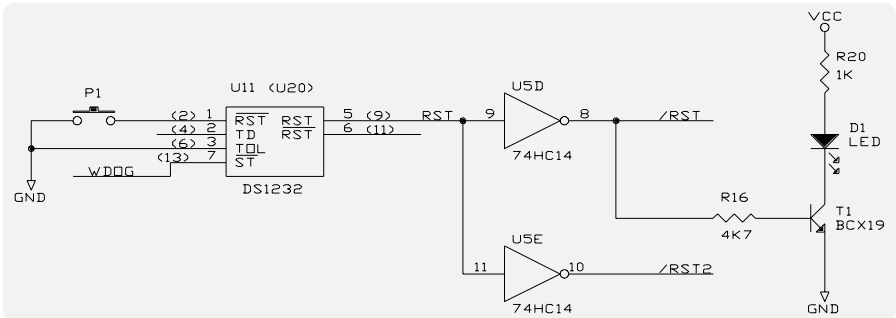

Figure 82

### 3.12.7 Ejecutivo Coin Mechanism Communication

This is a series line communication directly controlled by the microprocessor via U16A, U15C, U17E and U17F.

"TXD" is a transmission line to the coin mechanism and "RXD" is a reception line to the microprocessor. This communication is activated with the program-controlled switch, "S-EJECUTIVO."

Communication with the EJECUTIVO coin mechanism should be done by galvanically separating the machine from the coin mechanism using opto-coupling circuit, U19 designated ILCT6. This circuit communicates via one beam of infrared light for transmission and another for reception.

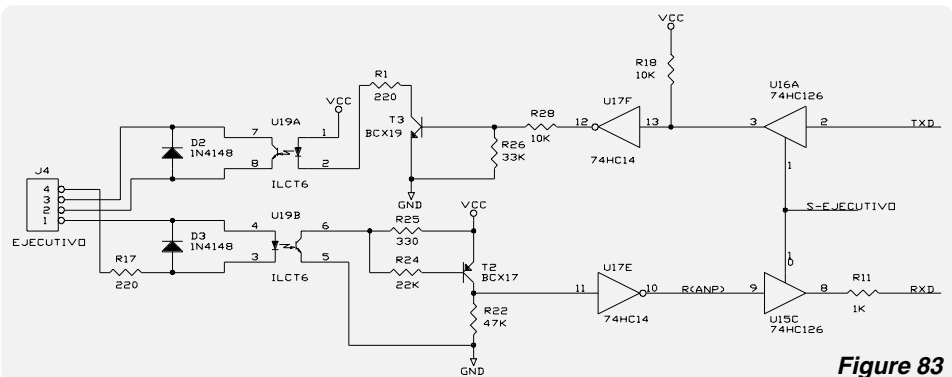

Figure 83



### 3.12.8 MDB Coin Mechanism Communication

This is a series line communication directly controlled by the microprocessor via U16B and U16C.

"TXD" is a transmission line to the coin mechanism and "RXD" is a reception line to the microprocessor. This communication is activated via the program-controlled switch, "S-MDB".

In this case the opto-coupling circuit is found in the coin mechanism and not on the machine Control Card.

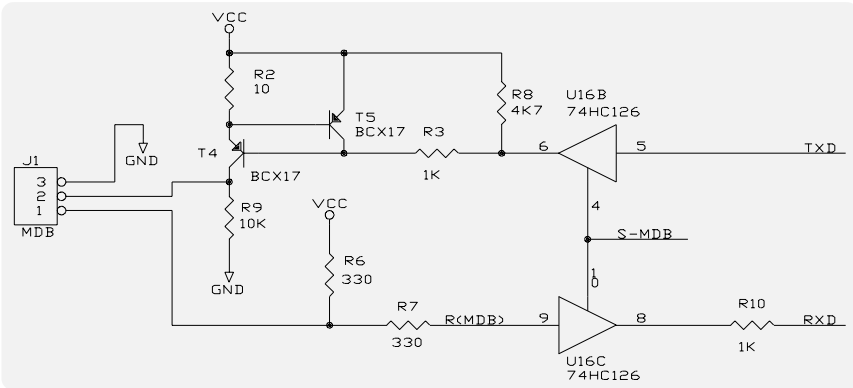

Figure 84

### 3.12.9 RS232 Exterior Control

Series RS232 communication is performed by U13, designated MAX 202. This circuit converts the voltage levels of the TXD and RXD signals into voltages between +12 v and -12 v which are those appropriate for series RS232 communication. A direct communication for a RS232 connector is located in the J2 connector for this purpose.

The microprocessor circuit controls this communication via line "S-232" of the U14C and U14A.

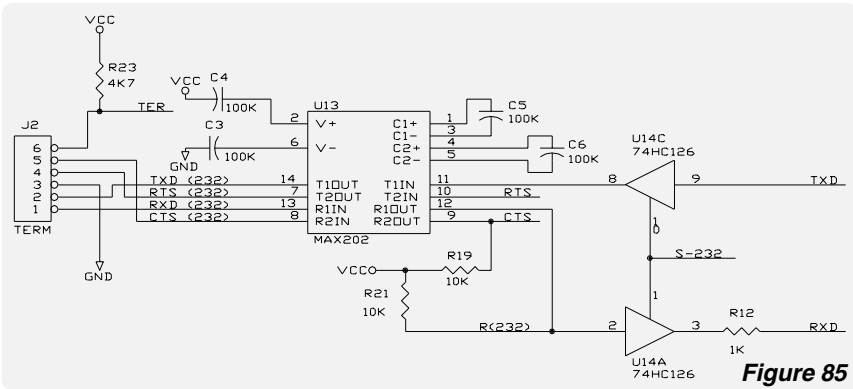

Figure 85

### 3.12.10 Infrared Communication

This is a series communication established by activating the U14B and U14D via the signal "S-EXP."

The infrared card is connected to the J2 connector on the Display Card where signal R (I) is sent and signal T (I) is received.

This line of communication can also be used for other objectives such as remote communications (Modem, Radio etc.).

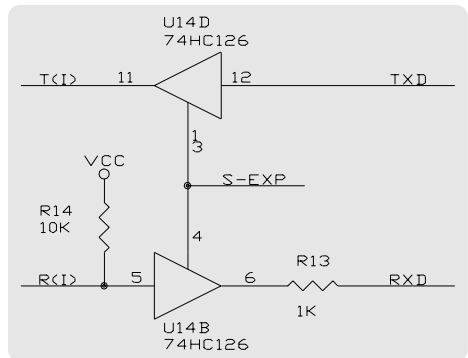

**Figure 86**



## 4.- Troubleshooting

Malfunctions are divided into two groups:

- ✓ Malfunctions "**detected**" by the autocheck system incorporated into the machine program
- ✓ Malfunctions "**undetected**" by the autocheck system

### 4.1 Detected Malfunctions

This section will indicate the message shown in the display, its possible cause, and the defective component in order of probability.

The possible "**cause**" is determined by the checks which the Control Card performs of the different peripherals according to the program stored in the Eprom memory.

These malfunction can be classified into two groups:

- ✓ **TOTAL:** The machine become completely inoperable, showing "**OUT OF ORDER**" in the display
- ✓ **PARTIAL:** The machine continues operating with some element malfunctioning without showing any message

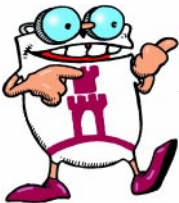

**YOU MUST ENTER "PROGRAMMING" TO IDENTIFY BOTH "TOTAL" AND "PARTIAL" MALFUNCTIONS.**

Once the malfunction is corrected, the machine may be put back into operation by simply entering and exiting programming using key **C** in the programming control or the **red button** found on the back of the Display Card.



Figure 87



## 4.2 Total Malfunctions: Machine Out of Order

<b>MESSAGE</b>	<b>F00 ERR. EXTRACT XX (XX=AA.....GG)</b>	
<b>Definition</b>	EXTRACTOR UNIT MALFUNCTION	
<b>Cause</b>	An extractor motor is in continuous operation	
	<b>DETECTION</b>	<b>MALFUNCTIONING ELEMENT</b>
	The Control Card is counting the impulses reaching the motor's run-end microswitch. If three or more are emitted within a certain time it automatically goes out of order.	<ul style="list-style-type: none"> <li>✓ I/O Card together with some short-circuited transistor or circuit</li> <li>✓ Short-circuited shelf card</li> </ul>

<b>MESSAGE</b>	<b>F01 ERR. RETURN</b>	
<b>Definition</b>	COIN RETURN MALFUNCTION	
<b>Cause</b>	The coin returner motor is in continuous operation	
	<b>DETECTION</b>	<b>MALFUNCTIONING ELEMENT</b>
	The Control Card is counting the impulses reaching the motor's run-end microswitch. If three or more are emitted within a certain time it automatically goes out of order.	<ul style="list-style-type: none"> <li>✓ I/O Card together with transistor Q19 or U10 short-circuited</li> </ul>

<b>MESSAGE</b>	<b>F02 ERR. EEPROM</b>	
<b>Definition</b>	EEPROM MEMORY MALFUNCTION	
<b>Cause</b>	EEPROM is not recording correctly.	
	<b>DETECTION</b>	<b>MALFUNCTIONING ELEMENT</b>
	<p>After EEPROM scripting an OK message is emitted when successful. If not, error. If the EEPROM differs from the EPROM in version, there may be a change in the structures.</p> <p>A block is scripted and the checksum calculated. If no match, error.</p> <p>Each time a block is read and the checksum differs from the EPROM memory field, an error is recorded.</p>	<ul style="list-style-type: none"> <li>✓ Control Card with the EEPROM memory damaged</li> </ul>



<b>MESSAGE</b> F03 ERR. CONFIG	
<b>Definition</b>	ALTERED *CONFIGURATION* DATA
<b>Cause</b>	Ram and EEPROM memory checksums do not match
<b>DETECTION</b>	<b>MALFUNCTIONELEMENT</b>
RAM checksum is confirmed and compared with that of the EEPROM memory. If they do not match, an attempt is made to copy the configuration from the EEPROM memory to the RAM. If this fails, and error occurs.	✓ Control Card with either damaged or altered RAM or EEPROM memory

**\*CONFIGURATION FUNCTIONS\***

220	OPEN SALE	452	BEEPER, Y/N
221	SIMPLE SALE	467	TEMP. CONFIG
223	MAX. CREDIT	468	COLD GROUP
401	CÓDIGO PROG.	470	NUM. MÁQUINA
420	PUBLICITY MSG .	472	OPER. CODE
425	TEMP. MSG	520	CLOCK OPTS
430	LANGUAGE	533	DAILY ILLUM. CYCLE
431	COINAGE	534	WEEKLY ILLUM. CYCLE
440	PERS. MENU	535	DAILY GROUP. CYCLE
		536	WEEKLY GROUP. CYCLE

<b>MESSAGE</b> F03 NO PRICE	
<b>Definition</b>	*SELECTION CONFIGURATION*, DATA ALTERED
<b>Cause</b>	Ram programming does not coincide with EEPROM memory
<b>DETECTION</b>	<b>MALFUNCTIONING ELEMENT</b>
RAM checksum is confirmed and compared with that of the EEPROM memory. If they do not match, an attempt is made to copy the configuration from the EEPROM memory to the RAM. If this fails, and error occurs.	✓ Control Card with either damaged or altered RAM or EEPROM memory

## SELECTION CONFIGURATION FUNCTIONS\*

<b>201</b>	<b>PRICE PROG.</b>	<b>301</b>	<b>FAM./PROD.CODE</b>
<b>210</b>	<b>IMPULSE PROG.</b>	<b>303</b>	<b>PROMO</b>

<b>MESSAGE</b>	<b>F04 ERR. COIN RETURN</b>	
<b>Definition</b>	COIN RETURN MALFUNCTION	
<b>Cause</b>	The coin return motor does not turn correctly	
	<b>DETECTION</b>	<b>MALFUNCTIONING ELEMENT</b>
	<p>The run-end microswitch of the coin return module sends a signal to the Control Card each time the motor makes a 360° turn. If this signal takes more than 7 seconds to be sent or lasts more than 2 seconds, an error occurs.</p>	<ul style="list-style-type: none"> <li>✓ <b>If the motor turns:</b> <ul style="list-style-type: none"> <li>- Run-end microswitch damaged</li> <li>- Cam damaged</li> <li>- Run-end microswitch cable broken</li> </ul> </li> <li>✓ <b>If the motor does not turn:</b> <ul style="list-style-type: none"> <li>- Motor damaged</li> <li>- Motor cable damaged</li> <li>- Coin return interface bundle damaged</li> <li>- I/O Card damaged</li> </ul> </li> </ul>

<b>MESSAGE</b>	<b>F05 ER. BUTTON</b>	
<b>Definition</b>	COIN RETURN OR PROGRAMMING BUTTON MALFUNCTION	
<b>Cause</b>	The coin return button or that of programming has remained active for more than 15 seconds.	
	<b>DETECTION</b>	<b>MALFUNCTIONING ELEMENT</b>
	<p>The Control Card monitors the time the buttons are pressed.</p> <p>They are rearmed automatically when no longer pressed.</p>	<ul style="list-style-type: none"> <li>✓ The coin return button is stuck and remains permanently pressed</li> <li>✓ I/O Card damaged</li> <li>✓ Control Card damaged</li> </ul>



<b>MESSAGE</b> F09 ER. LOW VOLTAGE	
<b>Definition</b>	VOLTAGE BELOW FUNCTIONING LEVEL
<b>Cause</b>	Network voltage is lower than the minimum necessary for correct operation.
DETECTION	MALFUNCTIONING ELEMENT
It is verified that for 10 seconds the secondary voltage (24 Vac) of the transformer is inferior to the operational one. If correct input is maintained for 60 seconds, automatic rearming occurs.	<ul style="list-style-type: none"> <li>✓ Fall in power source voltage</li> <li>✓ I/O Card detection circuit damaged</li> <li>✓ Transformer damaged or undercharged</li> </ul>

<b>MESSAGE</b> F10 ER. TEMPERAT	
<b>Definition</b>	TEMPERATURE SENSOR ERROR
<b>Cause</b>	Communication lost between sensor and Control Cardl.
DETECTION	MALFUNCTIONING ELEMENT
The Control Card communicates with the Temperature Sensor every 5 seconds. If communication fails for more than 2 hours, an error occurs.	<ul style="list-style-type: none"> <li>✓ Damaged temperature sensor</li> <li>✓ Sensor cable damaged</li> <li>✓ I/O Card damaged</li> <li>✓ Control Card damaged</li> </ul>

## 4.3 Partial Malfunctions: Machine Operating

<b>MESSAGE</b> <b>AO1 COIN MECHANISM ERROR</b>	
<b>Definition</b>	COIN MECHANISM ERROR
<b>Cause</b>	Communication with coin mechanism lost.
<b>DETECTION</b>	<b>MALFUNCTIONING ELEMENT</b>
The Control Card is in permanent communication with the coin mechanism and if it fails for more than 15 seconds, an error occurs.	<ul style="list-style-type: none"> <li>✓ Coin mechanism damaged.</li> <li>✓ Coin mechanism connection bundles damaged.</li> <li>✓ Control Card damaged</li> </ul>

<b>MESSAGE</b> <b>AO2 CANAL ERROR XX (XX=AA.....GG)</b>	
<b>Definition</b>	COIL MOTOR OUT OF ORDER
<b>Cause</b>	A coil is out of order.
<b>DETECTION</b>	<b>MALFUNCTIONING ELEMENT</b>
The Control Card has detected a motor, but when any is becomes active, it should recieve an impulse from the run-end microswitch with a duration less than 2 seconds in less than 7 seconds. If either of these conditions is not met, an error occurs.	<ul style="list-style-type: none"> <li>✓ Coil motor out of order</li> <li>✓ Run-end microswitch damaged</li> <li>✓ Motor cabling damaged</li> <li>✓ Shelf card damaged</li> <li>✓ I/O Card damaged</li> <li>✓ Control Card damaged</li> </ul>

<b>MESSAGE</b> <b>AO3 KEYBOARD ERROR</b>	
<b>Definition</b>	KEYBOARD FAILURE
<b>Cause</b>	A keyboard key is permanently pressed
<b>DETECTION</b>	<b>MALFUNCTIONING ELEMENT</b>
If the Control Card detects a selection key pressed for more than 15 seconds, an error occurs. When the key is no longer pressed, it automatically re-arms.	<ul style="list-style-type: none"> <li>✓ Keyboard with some key pressed</li> <li>✓ I/O Card damaged</li> <li>✓ Control Card damaged</li> </ul>



<b>MESSAGE</b> <span style="background-color: #e0ffe0;">R04 ACCOUNTING ERROR</span>	
<b>Definition</b>	ACCOUNTING ERROR
<b>Cause</b>	Accounting data has been lost or damaged.
<b>DETECTION</b>	<b>MALFUNCTIONING ELEMENT</b>
If accounting checksum data does not match it is erased and an error occurs.	✓ Control Card damaged

<b>MESSAGE</b> <span style="background-color: #e0ffe0;">R06 CLOCK ERROR</span>	
<b>Definition</b>	CLOCK FAILURE
<b>Cause</b>	The current time clock is stopped or damaged
<b>DETECTION</b>	<b>MALFUNCTIONING ELEMENT</b>
If the clock is stopped for 15 seconds or is slow an error occurs. It attempts to rearm every 5 seconds.	✓ Control Card RAM is damaged

## 4.4 Event Log

To assist technical service, there is a function designated "**EVENT LOG**." This function lists the last 50 events recorded in the machine so that the technician can evaluate its performance.

The description of these events is made using an event code and the time and date of the event. When the number of events surpasses 50, the oldest events are erased in favour of the newest.

To enter this function:

- Access function "**010**" by pressing key **C** or the red programming button.
- Press key **A** until "**EVENT LOG**" appears in the display.
- Repeatedly press key **A** view all recorded events.
- To exit programming for operation either press key **C** or the **red programming button**.

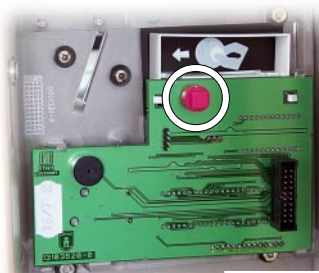

**Figure 88**

### 4.4.1 Event Code Table

CODE	DESCRIPTION
<b>0x02 : xx (coil motor)</b>	A coil motor is working by itself.
<b>0x03 : xx (coil motor)</b>	A motor does not start or its operation is not detected.
<b>0x0E : 0</b>	The coin return motors starts by itself
<b>0x0E : 1</b>	The coin return motor does not start or its movement is not detected.
<b>0x11 : 0</b>	There is no communication with coin returner.
<b>0x12 : 0</b>	Programming or coin return button activated
<b>0x13 : 0</b>	A selection button is activated.
<b>0x17 : 0</b>	Error in configuration programming.
<b>0x17 : 0</b>	Error in selection programming.
<b>0x20 : 1</b>	The machine has been shut down less than 5 seconds
<b>0x20 : 0</b>	The machine has come on
<b>0x21 : 0</b>	The machine has been shut down more than 5 seconds.
<b>0x23 : 1</b>	A VTM communication has been produced with rasters CC,CT and PP.
<b>0x23 : 0</b>	A VTM communication has been produced with the rest of the rasters.
<b>0x30 : 0</b>	EEPROM configuration has been upgraded
<b>0x31 : 0</b>	EEPROM selection configurations have been upgraded
<b>0x33 : 0</b>	General accounting has been erased.
<b>0x33 : 1</b>	The coin return tube accounting has been erased (MDB coin mechanism).
<b>0x33 : 2</b>	Accounting error.
<b>0x36 : 0</b>	Programming error
<b>0x37 : 0</b>	EEPROM error.
<b>0x38 : 0</b>	Low input voltage
<b>0x39 : 0</b>	Complete erasure of the RAM and EEPROM (except Event Log).
<b>0x3A : 0</b>	The clock is stopped or malfunctioning.
<b>0x3B : 0</b>	Temperature sensor failure

## 4.5 Test Function

This function verifies the operation of all the elements composing the machine.

When the machine is in operation, this function may be accessed by pressing the red programming button for four seconds until the message "**TEST FUNCTION**" appears. The different elements of the machine will now begin to be tested. To change the TEST from one element to another, press the coin return button.



Elements appear in the following order:

- 1.- Ejecutivo Coin Mechanism Communication
- 2.- MDB Coin Mechanism Communication
- 3.- Display Card LEDs
- 4.- Coin Return Motor
- 5.- Cold Group
- 6.- Display Test
- 7.- Temperature Sensor
- 8.- Illumination
- 9.- Programming Box (all keys must be pressed)
- 10.- Selection Keyboard (all keys must be pressed)
- 11.- Product Extractor Motors



*Figure 89*



## 4.6 Undetected Malfunctions

Affected Modue	DISPLAY CARD
SYMPTOMS	MALFUNCTIONING ELEMENT
Display does not come on although the rest of the machine is functioning normally.	<ul style="list-style-type: none"> <li>✓ Display Card</li> <li>✓ Display Card bundle</li> <li>✓ Power Card (VDD input)</li> <li>✓ I/O Card</li> <li>✓ Control Card</li> </ul>
"Exact Change" LED does not come on	<ul style="list-style-type: none"> <li>✓ F04 is not activated in Ejecutivo coin mechanism</li> <li>✓ Display Card</li> <li>✓ Display Card bundle</li> <li>✓ I/O Card</li> <li>✓ Control Card</li> </ul>
"Sold Out" LED does not come on	<ul style="list-style-type: none"> <li>✓ Display Card</li> <li>✓ Display Card bundle</li> <li>✓ I/O Card</li> <li>✓ Control Card</li> </ul>
Coin return button does not work	<ul style="list-style-type: none"> <li>✓ Button membrane damaged</li> <li>✓ Display Card</li> <li>✓ Display Card bundle</li> <li>✓ I/O Card</li> <li>✓ Display Card</li> </ul>
Beeper does not work	<ul style="list-style-type: none"> <li>✓ Beeper</li> <li>✓ Display Card</li> <li>✓ Display Card bundle</li> <li>✓ I/O Card</li> <li>✓ Control Card</li> </ul>
Programming button does not work	<ul style="list-style-type: none"> <li>✓ Damaged button</li> <li>✓ Display Card</li> <li>✓ Display Card bundle</li> <li>✓ I/O Card</li> <li>✓ Control Card</li> </ul>



<b>Affected Module</b>		<b>PROGRAMMING BOX</b>
<b>SYMPTOMS</b>	<b>MALFUNCTIONING ELEMENT</b>	
One or more buttons do not function.	<ul style="list-style-type: none"> <li>✓ The button or buttons of the programming box</li> <li>✓ Programming box bundle</li> <li>✓ Programming box interface bundle</li> <li>✓ I/O Card</li> <li>✓ Control Card</li> </ul>	

<b>Affected Module</b>		<b>SELECTION KEYBOARD</b>
<b>SYMPTOMS</b>	<b>MALFUNCTIONING ELEMENT</b>	
One or more keys do not function.	<ul style="list-style-type: none"> <li>✓ Key or keys on the keyboard</li> <li>✓ Keyboard bundle</li> <li>✓ I/O Card</li> <li>✓ Control Card</li> </ul>	

<b>Affected Module</b>		<b>EXTRACTOR MOTORS</b>
<b>SYMPTOMS</b>	<b>MALFUNCTIONING ELEMENT</b>	
A motor does not function and the "Sold Out" light comes on when the selection is made.	<ul style="list-style-type: none"> <li>✓ Motor damaged with coil interrupted</li> <li>✓ Price not programmed (9999)</li> <li>✓ Shelf card</li> <li>✓ Shelf card interface bundle - I/O Card</li> <li>✓ I/O Card</li> <li>✓ Control Card</li> </ul>	
Dispenses two products	<ul style="list-style-type: none"> <li>✓ Defective motor cam acting as a simple cam</li> <li>✓ Defective run-end microswitch</li> <li>✓ Double coil with impulse programming at two</li> <li>✓ Failed connection in the Shelf Card and/or I/O Card</li> </ul>	
The coil does not advance 360° resulting in partial extraction of the product	<ul style="list-style-type: none"> <li>✓ Defective run-end microswitch</li> <li>✓ Coil programmed with one impulse</li> </ul>	

<b>Affected Module</b>		<b>COIN RETURN MODULE</b>
<b>SYMPTOMS</b>	<b>MALFUNCTIONING ELEMENT</b>	
The 6.3 A. fuse blows when coin return is pressed.	<ul style="list-style-type: none"> <li>✓ Short-circuited coin return motor</li> <li>✓ Short-circuited diode</li> <li>✓ Diode backwards</li> </ul>	

<b>Affected Module</b>		<b>CONTROL CARD</b>
<b>SYMPTOMS</b>	<b>MALFUNCTIONING ELEMENT</b>	
Machine does not turn on and the Control Card LED diode is blinking.	<ul style="list-style-type: none"> <li>✓ Control Card</li> </ul>	

<b>Affected Module</b>		<b>POWER CARD</b>
<b>SYMPTOMS</b>	<b>MALFUNCTIONING ELEMENT</b>	
Machine does not come on.	<ul style="list-style-type: none"> <li>✓ The 6.3 Amp fuse is blown</li> <li>✓ Circuit 78H05 (T2) is damaged</li> </ul>	

<b>Affected Module</b>		<b>POWER SOURCE</b>
<b>SYMPTOMS</b>	<b>MALFUNCTIONING ELEMENT</b>	
The machine does not come on nor does the keyboard of the power switch light up.	<ul style="list-style-type: none"> <li>✓ There is no voltage in the outlet where the machine is plugged in.</li> <li>✓ Fuse F1 (10 Amps) is blown</li> <li>✓ The power cable is loose from the connection plug on the power card.</li> <li>✓ The power cable has broken wires.</li> </ul>	
When the machine is plugged in without turning it on, the power source disconnects either because a magnetothermic protector or an installation fuse blows.	<ul style="list-style-type: none"> <li>✓ Short-circuited varistor</li> </ul>	



Affected Module	ILLUMINATION
SYMPTOMS	DEFECTIVE ELEMENT
Flourescent tube does not come on	<ul style="list-style-type: none"> <li>✓ Fluorescent tube</li> <li>✓ Reactance</li> <li>✓ Primer</li> <li>✓ Illumination bundle</li> <li>✓ Power Source Card</li> <li>✓ I/O Card</li> <li>✓ Check illumination funtions 533 and 534</li> <li>✓ Control Card</li> </ul>

Affected Module	COLD GROUP
SYMPTOMS	DEFECTIVE ELEMENT
Power does not reach the Cold Group	<ul style="list-style-type: none"> <li>✓ Group power source bundle</li> <li>✓ Power card</li> <li>✓ I/O Card</li> <li>✓ Control Card</li> </ul>
Contianer fan does not work	<ul style="list-style-type: none"> <li>✓ Fan motor damaged</li> <li>✓ Container fan bundle damaged</li> </ul>
All of the machine works except the compressor	<ul style="list-style-type: none"> <li>✓ Compressor damaged</li> <li>✓ Clixon damaged</li> <li>✓ Start up relay damaged</li> <li>✓ Start up condenser damaged</li> </ul>
The compressor starts but stalls after a few seconds	<ul style="list-style-type: none"> <li>✓ Compressor damaged</li> <li>✓ Clixon damaged</li> <li>✓ Condenser needs cleaning</li> <li>✓ Condenser fan not working</li> </ul>

continued...

Affected Module	COLD GROUP
SYMPTOMS	DEFECTIVE ELEMENT
<p>The compressor functions but product is not cooled.</p>	<ul style="list-style-type: none"> <li>✓ Temperature function 468 programmed too high</li> <li>✓ Group condenser needs cleaning</li> <li>✓ Condenser fan not working</li> <li>✓ Low refrigerant in Cold Group. This can be observed in the evaporator because ice forms on the first spirals but not in the rest.</li> <li>✓ Humidity in the cold circuit. This can be acertained by confirming the presence of a ball of ice around the capillary tube just at the entrance of the evaporator.</li> <li>✓ The capillary tube has a break inside the return tube which can be noted by ice forming in the return tube and not in the evaporator.</li> </ul>
<p>A block of ice forms in the evaporator</p>	<ul style="list-style-type: none"> <li>✓ Container fan does not work.</li> </ul>



Marcas del



**AZKOYEN**

**AZKOYEN MEDIOS DE PAGO S.A.**



*Teidde*